

SINCE 1885

Granite City Tool

Everything for stone working



Call Today
800-328-7094



Our Website
is your
Digital Desk

We carry all major
tool brands and the
largest equipment
shipped right
to your door.

Granite City Tool
An international distributor of
diamond tools and stone working
equipment. We provide all the
tooling for every machine
used in the stone industry.

Monument Division
Full Service Supplier to the
Memorial Stone Industry.

Stone Countertop Division
Everything you need to fabricate
natural stone countertops.
Call for your Fabrication Catalog.

GCT is your
one-stop supplier
for stone tools & supplies

Everything for Stone Working

Granite City Tool's most important function is to be part of our customer's team and to satisfy their needs in order to help them create success, as they help to create our success. We continue to source the highest quality products at the most competitive prices and pass these benefits along to our customers. We will also maintain our integrity in our ability to be the most diverse service and product oriented supplier for the Stone Industry. We will continue from our history into our future, to be innovators and trail-blazers of new technologies for the stone industry.

Impact Etching Machines



PG.
16

Nozzles and Abrasives



PG.
73



PG.
76

Lithichrome Products



PG.
78



PG.
77

www.granitecitytool.com

Granite City Tool



























Everything for stone working

Toll Free Phone: 800-328-7094

Toll Free Fax: 866-522-1817

www.granitecitytool.com

Table of Contents (Index on Page 127)

| | |
|---|------------|
|  Chisels & Hammers..... | 2 |
|  Sculptor Tools | 13 |
|  Stone Etching Tools..... | 15 |
|  Stone Drills & Bits | 17 |
|  Stone Splitting | 20 |
|  Diamond Polishing Wheels & Buffing | 21 |
|  Diamond Grinding Wheels & Silicon Carbide..... | 26 |
|  Diamond Grinding & Shaping Wheels..... | 28 |
|  Diamond Polishing Discs & Backer Heads..... | 26, 30, 33 |
|  Diamond Drum Wheels | 34 |
|  Diamond Routers & Profile Bits..... | 36 |
|  Core Drill Machines & Core Bits | 39, 41 |
|  Diamond Blades | 42 |
|  Stone Saws | 47 |
|  Polishers & Grinders..... | 52 |
|  Adaptors..... | 56 |
|  Stencil Tools, Stencil, & Lettering | 58 |
|  Sandblast & Abrasives..... | 67 |
|  Lithichrome..... | 77 |
|  Hoods & Safety Equipment | 80 |
|  Stone Care & Repair..... | 85 |
|  Adhesives..... | 91 |
|  Air Compressors & Accessories | 97 |
|  Setting & Handling | 104 |
|  Shop Supplies..... | 114 |
|  Construction | 118 |
|  Ruemelin, Lindsay, & Abrasive Pickup Parts Lists..... | 120 |

Sales Representatives: Mark Eisenwiter.....(320) 257-7308

Jim Larsen(320) 257-7302



ORDER ONLINE AT: ✓ Easy
✓ Fast
www.granitecitytool.com ✓ Reliable

Dallett Pneumatic Carving Tool: Type B

The "TYPE B" is designed to run very smoothly at all power levels. Available in Bantam, 1/2", 3/4", and 1" sizes; with a shorter piston stroke than the Type D; all are able to provide excellent power for heavier work yet still run smoothly at low power for fine work. All sizes also have a shaped fingergrasp for comfort and ease of control.

| Specifications | Sizes | | | |
|---------------------------|-----------|-----------|-----------|-----------|
| | BANTAM | 1/2" B | 3/4" B | 1" B |
| Diameter of Piston | 15/32 " | 1/2" | 3/4 " | 1 " |
| Outside Diameter | 7/8 " | 1-1/4" | 1-1/2 " | 1-5/8 " |
| Length Overall | 5 " | 5-3/4" | 6-3/4 " | 7-1/2 " |
| Weight - lbs. - oz. | 0 - 9 | 1 - 8 | 2 - 12 | 3 - 8 |
| Size Shank | 5/16 " | 1/2" | 1/2 " | 1/2 " |
| Air Consumption (cu. Ft.) | 3 | 4 | 4 | 6 |
| Item # | 3303-0007 | 3303-0011 | 3303-0003 | 3303-0004 |

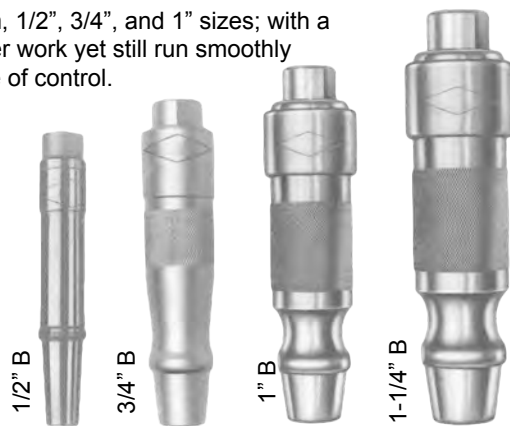

Dallett Pneumatic Carving Tool: Type D

The Dallett "TYPE D" tools provide the maximum power per size ratios available anywhere. By using a longer stroke than our other pneumatic tools, the TYPE D strikes a harder blow over the full power range. Its simple design and rugged construction afford reliable and economical operation on the most demanding work. The 1" and 1-1/4" sizes are suitable for larger roughing applications and offer a shaped fingergrasp for greater control and comfort during extended use. The 1/2" and 3/4" sizes are perfect for finer jobs where detail and precision are required.

| Specifications | Sizes | | | |
|---------------------------|-----------|-----------|-----------|-----------|
| | 1/2" D | 3/4" D | 1" D | 1-1/4" D |
| Diameter of Piston | 9/16" | 3/4" | 1" | 1-1/4" |
| Outside Diameter | 1-1/8" | 1-5/16" | 1-11/16" | 2" |
| Length Overall | 5-3/4" | 6-3/4" | 7-7/8" | 8-3/4" |
| Weight - lbs. - oz. | 1 - 4 | 1 - 14 | 3 - 8 | 5 - 10 |
| Size Shank | 1/2" | 1/2" | 1/2" | 5/8" |
| Air Consumption (cu. Ft.) | 3 | 4 | 6 | 8 |
| Item # | 3303-0001 | 3303-0002 | 3303-0005 | 3303-0010 |

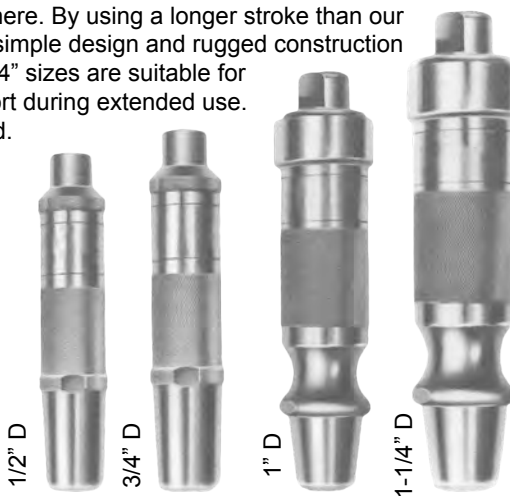

The Bantum Pneumatic Carving Set

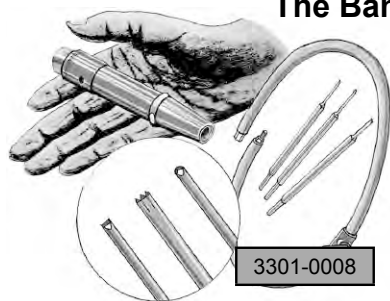

Weighs only 9 ounces!
5/16" shank carbide chisels for detail carving!
Smooth action with a wide power range!
Guaranteed against breakage!

This set includes: The Bantum Pneumatic Tool, 10 ft. hose assembly with all hardware installed, and three chisels: 1/8" Flat Chisel, 3/16" Rondel Chisel, and 1/4" Tooth Chisel.

3301-0008



Bantum Chisels

| Item # | Shank | Width of Blade |
|--------------|-------|----------------|
| 3302-0192 | 5/16" | 1/8" |
| * 3301-0016 | 5/16" | 3/16" |
| * 3301-0017 | 5/16" | 1/4" |
| ** 3301-0021 | 5/16" | 3/8" |

For use with the Bantum Pneumatic Tool/Hammer

* Also available in rondel blade
** Also available in rondel or with teeth

Air Tool Comfort Grip

The snug-fitting rubber loops can be "shimmied" onto your air tool, providing you with a wooden handle that will reduce vibration while maintaining the speed and control of your tool.



Pneumatic Tool (not included)

| Fits Pneumatic Tool Size | Item # |
|--------------------------|-----------|
| 1" B and 1" D | 3301-0026 |

Inlet Bushings



| | | |
|-------------|-------|-----------|
| 1/4" x 1/4" | No. 1 | 3301-0012 |
| 3/8" x 1/4" | No. 2 | 2707-0060 |

Finishing Chisels



Used for general: carving, sculpting and lettering

* Available sizes for comfort sleeve

| Stock | Shank | Blade Width | Item # |
|-------|-------|-------------|-----------|
| 1/2" | 1/2" | 1/8" * | 3302-0008 |
| 1/2" | 1/2" | 3/16" * | 3302-0011 |
| 1/2" | 1/2" | 1/4" * | 3302-0014 |
| 1/2" | 1/2" | 3/8" * | 3302-0018 |

Machine Chisels



Used where heavy removal and rough usage is required

* Available sizes for comfort sleeve

| Stock | Shank | Blade Width | Item # |
|-------|-------|-------------|-----------|
| 1/2" | 1/2" | 1/4" * | 3302-0014 |
| 1/2" | 1/2" | 1/2" * | 3302-0020 |
| 5/8" | 1/2" | 5/8" * | 3302-0026 |
| 3/4" | 1/2" | 3/4" | 3302-0021 |
| 3/4" | 5/8" | 3/4" | 3302-0028 |

Roughing Chisels



Used for heavy stock removal and rough usage.

* Available sizes for comfort sleeve

| Stock | Shank | Blade Width | Item # |
|-------|-------|-------------|-----------|
| 5/8" | 1/2" | 5/8" * | 3302-0042 |
| 3/4" | 1/2" | 3/4" | 3302-0031 |

Clean Up Chisels

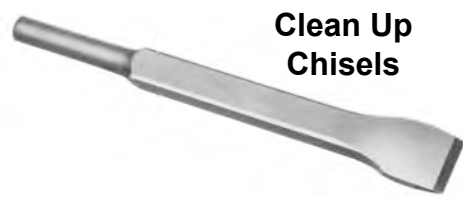

A finishing tool used as a scraper to close the grain.

* Available sizes for comfort sleeve

| Stock | Shank | Blade Width | Item # |
|-------|-------|-------------|-----------|
| 1/2" | 1/2" | 1" * | 3302-0032 |
| 5/8" | 1/2" | 1" * | 3302-0033 |
| 5/8" | 1/2" | 1-1/2" * | 3302-0039 |
| 5/8" | 1/2" | 2" * | 3302-0071 |
| 5/8" | 1/2" | 1-1/4" | 3302-0145 |
| 5/8" | 5/8" | 1-1/4" | 3302-0147 |

Carving Chisels

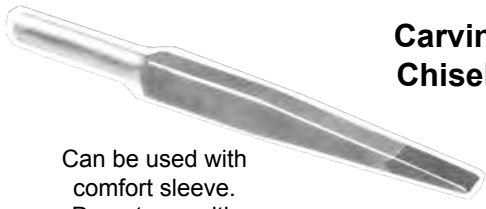

Can be used with comfort sleeve. Do not use with striking cap.



| Stock | Shank | Blade Width | Item # |
|-------|-------|-------------|-----------|
| 1/2" | 1/2" | 1/8" | 3302-0006 |
| 1/2" | 1/2" | 3/16" | 3302-0010 |
| 1/2" | 1/2" | 1/4" | 3302-0012 |
| 1/2" | 1/2" | 3/8" | 3302-0016 |
| 1/2" | 1/2" | 1/2" | 3302-0019 |
| 5/8" | 1/2" | 5/8" | 3302-0025 |
| 3/4" | 1/2" | 3/4" | 3302-0151 |

Carving Chisels have three times more carbide than standard carbide tipped chisels and are designed for detail carving and lettering work.

Available in straight, tooth, or rondel styles up to 3/4" wide.

Double Blade Chisel



Used after the 4-Point or 9-Point Chisel to take off high spots and quickly smooth surfaces.

* Available sizes for comfort sleeve

| Stock | Shank | Blade Width | Item # |
|-------|-------|-------------|-----------|
| 5/8" | 1/2" | 1-1/2" * | 3302-0069 |

Chisel Retainer



1/2" B Pneumatic Tool (not included)

A simple precision rubber part that loops onto your chisel. Easy to install and remove.

| Pneumatic Tool Size | Shank | Item # |
|----------------------|-------|-----------|
| 1/2" D Dallett Style | 1/2" | 3301-0032 |
| 3/4" D Dallett Style | 1/2" | 3301-0034 |
| 3/4" B Short Stroke | 1/2" | 3301-0035 |
| 1" D Dallett Style | 1/2" | 3301-0036 |

Air-Powered Carving Set



3301-0023

This set includes: "Type B" short stroke carving tool, 10 ft. air hose, tool pouch, and carbide carving chisels: 1/2" wide straight blade, 5/8" wide rondel blade, 3/4" wide tooth chisel



Carver's Drill

For use with pneumatic tools and/or stone hand hammers.

| Stock | Shank | Blade | Item # |
|-------|-------|-------|-----------|
| 1/2" | 1/2" | 1/8" | 3306-0005 |
| 1/2" | 1/2" | 3/16" | 3306-0006 |
| 1/2" | 1/2" | 3/8" | 3306-0008 |
| 1/2" | 1/2" | 1/4" | 3306-0007 |
| 5/8" | 1/2" | 1/2" | 3306-0001 |

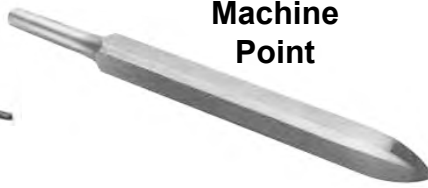

Machine Point

Used for roughing and taking off high spots.

| Stock | Shank | Item # |
|-------|-------|-----------|
| 1/2" | 1/2" | 3304-0001 |
| 5/8" | 5/8" | 3304-0003 |



Splitter or Cape Chisel

Used for crisping lines, joining corners, detailing, or splitting. Cuts are narrower and deeper. Also, used by masons for removing old mortar in preparation for re-pointing.

| Stock | Shank | Blade Width | Item # |
|-------|-------|-------------|-----------|
| 1/2" | 1/2" | 1/8" | 3302-0017 |
| 1/2" | 1/2" | 3/16" | 3302-0023 |
| 1/2" | 1/2" | 1/4" | 3302-0029 |
| 1/2" | 1/2" | 3/8" | 3302-0035 |

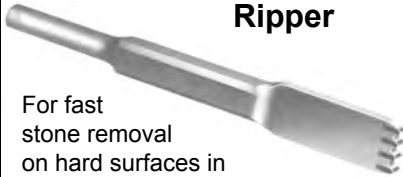

Ripper

For fast stone removal on hard surfaces in hard-to-reach places. Also used by masons for joint preparation.

| Stock | Shank | Teeth | Item # |
|-------|-------|-------|-----------|
| 1/2" | 1/2" | 2 | 3305-0001 |
| 1/2" | 1/2" | 3 | 3305-0002 |
| 5/8" | 1/2" | 4 | 3305-0004 |
| 5/8" | 5/8" | 4 | 3305-0005 |

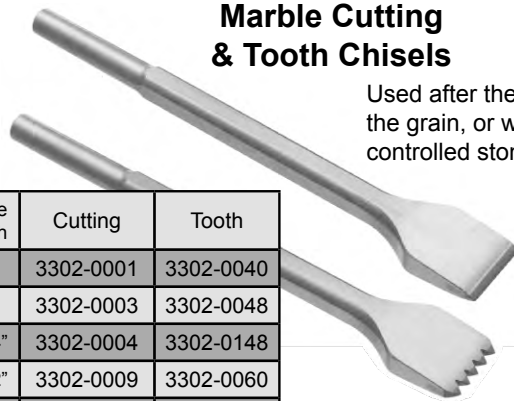

Marble Cutting & Tooth Chisels

Used after the tooth chisel to close the grain, or when slower, more controlled stone removal is desired.

| Shank | Blade Width | Cutting | Tooth |
|-------|-------------|-----------|-----------|
| 1/2" | 3/4" | 3302-0001 | 3302-0040 |
| 1/2" | 1" | 3302-0003 | 3302-0048 |
| 1/2" | 1-1/4" | 3302-0004 | 3302-0148 |
| 1/2" | 1-1/2" | 3302-0009 | 3302-0060 |
| 1/2" | 2" | 3302-0022 | 3302-0072 |
| 1/2" | 3" | 3302-0047 | 3302-0087 |

Please specify teeth style when ordering a, b, c, d, or e

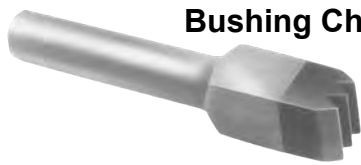

Three Blade Bushing Chisel

Smother than a double blade leaving an axed or brushed finish.

For use with pneumatic tools and/or stone hand hammers.

| Stock | Shank | Item # |
|-------|-------|-----------|
| 1/2" | 1/2" | 3302-0211 |
| 5/8" | 1/2" | 3302-0068 |



Criss-Cross Chisel

Cuts quickly, leaving a unique cross-hatched finish. Nice to follow a 9 point or three blade.

For use with pneumatic tools and/or stone hand hammers.

| Stock | Shank | Item # |
|-------|-------|-----------|
| 1/2" | 1/2" | 3302-0075 |
| 5/8" | 1/2" | 3302-0086 |
| 3/4" | 1/2" | 3302-0095 |



Cup Chisel

Excellent for curved areas and to make a smooth surface.

For use with pneumatic tools and/or stone hand hammers.

| Stock | Shank | Item # |
|-------|-------|-----------|
| 7/8" | 1/2" | 3302-0062 |



Striking Cap

3301-0001

Saves chisel shanks when used with a hammer.

NOTE: Striking Cap is not for use with all machine chisels.

4-Point Tooth Chisel



Ideal for roughing out work and leaving a coarse texture.

| Stock | Shank | Item # |
|-------|-------|-----------|
| 1/2" | 1/2" | 3302-0064 |
| 5/8" | 1/2" | 3302-0082 |
| 3/4" | 5/8" | 3302-0097 |
| 3/4" | 1/2" | 3302-0096 |

For use with pneumatic tools and/or stone hand hammers.

9-Point Tooth Chisel



Removes less material than 4 point but leaves a finer surface.

| Stock | Shank | Item # |
|-------|-------|-----------|
| 1/2" | 1/2" | 3302-0076 |
| 5/8" | 1/2" | 3302-0088 |
| 5/8" | 5/8" | 3302-0094 |
| 3/4" | 1/2" | 3302-0100 |
| 3/4" | 5/8" | 3302-0101 |

For use with pneumatic tools and/or stone hand hammers.

16-Point Tooth Chisel



Will smooth out surface from 9-point.

For use with pneumatic tools and/or stone hand hammers.

| Stock | Shank | Item # |
|-------|-------|-----------|
| 1" | 1/2" | 3302-0104 |

Limestone Chisels

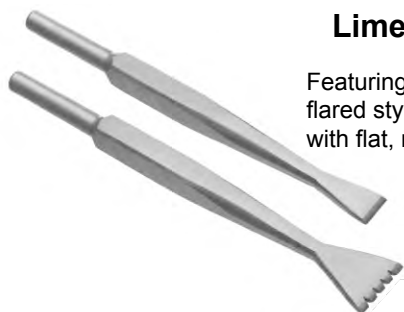

Featuring more finely tapered carbide blades with traditional flared styling, these Limestone Cutting Chisels are available with flat, rondel, tooth or nibbler blade.

* To order tooth, rondel or nibbler chisels, select blade width and place the letter that refers to the tooth style you would like.

| Stock | Shank | Blade Width | Item # |
|-------|-------|-------------|-----------|
| 5/8" | 1/2" | 3/4" | 3302-0207 |
| 5/8" | 1/2" | 1" | 3302-0208 |
| 5/8" | 1/2" | 1-1/4" | 3302-0209 |
| 5/8" | 1/2" | 1-1/2" | 3302-0210 |

Soft Stone Mallet Head Chisels

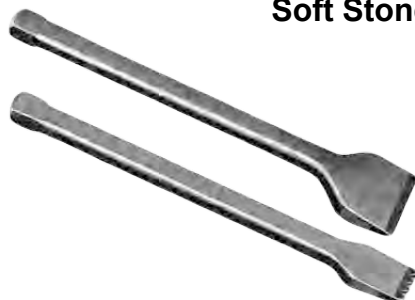

1/2" styles available with either flat or rondel blades.
5/8" stock also available with flat rondel or toothed blades. Carbide Tipped

Please specify teeth style when ordering

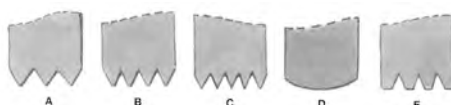

| Stock | Width | Item # |
|-------|--------|-----------|
| 1/2" | 3/4" | 3302-0163 |
| 1/2" | 1" | 3302-0168 |
| 1/2" | 1-1/4" | 3302-0169 |
| 1/2" | 1-1/2" | 3302-0175 |
| 1/2" | 2" | 3302-0176 |
| 1/2" | 2-1/2" | 3302-0177 |
| 1/2" | 3" | 3302-0170 |
| 5/8" | 1-1/4" | 3302-0172 |
| 5/8" | 1-1/2" | 3302-0173 |
| 5/8" | 2" | 3302-0174 |

Carbide Masonry Set

2301-0009



Our new Carbide Masonry Set includes three of our most versatile carbide stone working tools:

The Stone Buster, The 2" Mason's Chipper
The 1" Hand Point

The carbide-tipped stone buster gives you a splitting tool and striking hammer in one tool. It comes with a 16" wood handle (a fiberglass handle can be substituted for an additional charge).

The 2" carbide-tipped blade Mason's Chipper is perfect for light trimming or squaring stone. The steeply angled blade and beveled carbide tip make it easier to see your work. The 1" stock carbide-tipped Hand Point will be the workhorse of your tool set. Use it to rough out and remove high spots, which will help extend the life of your wider-blade carbide tools.

Chisel Whizard

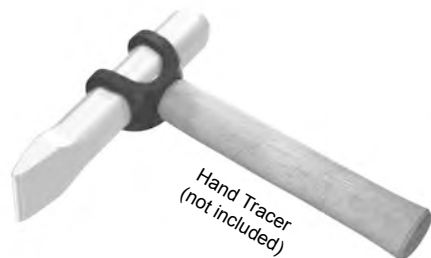

Get your hand out of harms way with this simple but effective device. The rubber loops firmly grip the tool handle but still allow you to adjust the blade angle any way you choose.

| Chisel Handle | Item # |
|---------------|-----------|
| 1" | 2301-0024 |
| 1-1/8" | 2301-0025 |



2310-0002

This set features carbide-tipped chisels, which will keep their edge and last many times longer than steel tools.

Hard Stone Hand Carving Set

- Tool Pouch for easy storage
- 1-1/2 lb. Round Hammer (6" handle)

Set Includes:

- 1/2" Hand Point
- 3/8" Hand Chisel
- 1/2" Hand Chisel w/ teeth
- 3/4" Mallet Head Chisel
- 1-1/4" Mallet Head Chisel



2306-0017

Contoured handle provides better grip for more powerful blows. Size: 1-3/8" round

Carbide Comfort Grip Hand Point

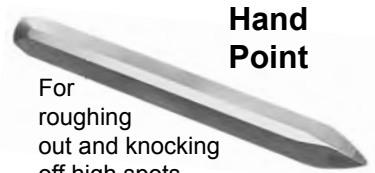

For roughing out and knocking off high spots.

Hand Point

| Stock | Item # |
|-------|-----------|
| 3/8" | 2306-0011 |
| 1/2" | 2306-0012 |
| 5/8" | 2306-0019 |
| 3/4" | 2306-0014 |
| 7/8" | 2306-0015 |
| 1" | 2306-0016 |



Carbide Heavy Hand Point

Heavier handle takes a harder blow.

2306-0018



Hand Chisel

For roughing out larger pieces.

| Size | Item # |
|------|-----------|
| 3/8" | 2304-0007 |
| 1/2" | 2304-0008 |
| 5/8" | 2304-0009 |
| 3/4" | 2304-0010 |
| 7/8" | 2304-0011 |
| 1" | 2304-0012 |



Hand Set

For breaking stone to size when the surface is relatively flat.

| Stock | Blade | Item # |
|--------|--------|-----------|
| 1" | 1-1/8" | 2308-0016 |
| 1" | 1-1/2" | 2308-0018 |
| 1" | 2" | 2308-0015 |
| 1-1/8" | 2" | 2308-0019 |
| 1-1/8" | 2-1/4" | 2308-0023 |
| 1-1/8" | 2-1/2" | 2308-0022 |
| 1-1/8" | 3" | 2308-0024 |
| 1-1/8" | 4" | 2308-0025 |



Offset Handset

Used when chipper style is desired, but more strength is needed.

| Stock | Blade | Item # |
|--------|--------|-----------|
| 1" | 1-1/8" | 2308-0030 |
| 1" | 1-1/2" | 2308-0027 |
| 1" | 2" | 2308-0021 |
| 1-1/8" | 2" | 2308-0020 |
| 1-1/8" | 3" | 2308-0050 |



Hand Tracer

For pitching and tracing lines to split stone.

| Stock | Blade Width | Item # |
|--------|-------------|-----------|
| 1" | 1-1/2" | 2309-0007 |
| 1" | 2" | 2309-0008 |
| 1-1/8" | 2" | 2309-0009 |
| 1-1/8" | 2-1/2" | 2309-0010 |
| 1-1/8" | 3" | 2309-0011 |
| 1-1/8" | 4" | 2309-0012 |



Mason Chipper

Offers a beveled blade for rock facing, trimming, or squaring stone.

| Stock | Blade Width | Item # |
|--------|-------------|-----------|
| 3/4" | 1-1/4" | 2303-0023 |
| 1" | 1-1/8" | 2303-0017 |
| 1" | 1-1/2" | 2303-0016 |
| 1" | 2" | 2303-0022 |
| 1-1/8" | 2" | 2303-0018 |
| 1-1/8" | 2-1/2" | 2303-0019 |
| 1-1/8" | 3" | 2303-0020 |



Monument Hand Chipper

Light duty trimming tool to crisp edges. For use on flat, smooth stone only. Use a HANDSET, or OFFSET for heavier work.

| Stock | Blade Width | Item # |
|--------|-------------|-----------|
| 3/4" | 1-1/4" | 2303-0007 |
| 1" | 1-1/2" | 2303-0009 |
| 1" | 1-3/4" | 2303-0011 |
| 1" | 2" | 2303-0010 |
| 1-1/8" | 3" | 2303-0013 |



Carbide Rocko Hand Tool

Based on traditional European mason's tool designs, our new ROCKO Carbide Hand Tools feature a specially angled blade that allows you to hold the chisel in a more vertical position when striking. This reduces the chance of Mis-striking the chisel head and offers more control when working on smaller or softer stones.

| Stock | Blade Width | Item # |
|-------|-------------|-----------|
| 5/8" | 5/8" | 2304-0013 |
| 5/8" | 1" | 2304-0014 |
| 3/4" | 1-1/4" | 2304-0015 |
| 7/8" | 7/8" | 2304-0016 |
| 1" | 1" | 2304-0017 |
| 1" | 2" | 2304-0018 |

Marble Lettering Chisel - Steel



| Stock | Blade | Item # |
|-------|-------|-----------|
| 1/2" | 1/2" | 3302-0002 |

Flared Chisel - Steel

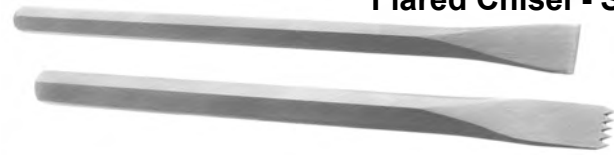

Please specify teeth style when ordering

Traditionally designed steel blade Flared Chisels are available with either flat, rondel, or toothed blades. Hex-shaped stocks are comfortable and well-balanced for fine work in softer stone. 1/2" hex sizes are also available with round shanks for use with pneumatic tools.

| Stock | Blade Width | Item # |
|-------|-------------|-----------|
| 3/8" | 1/2" | 3302-0134 |
| 3/8" | 5/8" | 3302-0135 |
| 3/8" | 3/4" | 3302-0136 |
| 1/2" | 5/8" | 3302-0137 |
| 1/2" | 3/4" | 3302-0138 |
| 1/2" | 1" | 3302-0139 |

Granite Hand Chisel, Steel



| Stock | Chisel |
|-------|-----------|
| 3/8" | 2304-0001 |
| 7/8" | 2304-0005 |
| 1" | 2304-0006 |

Marble Hand Point & Chisel Steel

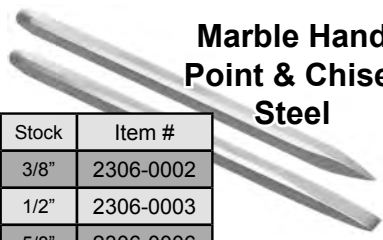

| Stock | Item # |
|-------|-----------|
| 3/8" | 2306-0002 |
| 1/2" | 2306-0003 |
| 5/8" | 2306-0006 |
| 3/4" | 2306-0007 |

Marble Cutting Chisel - Steel

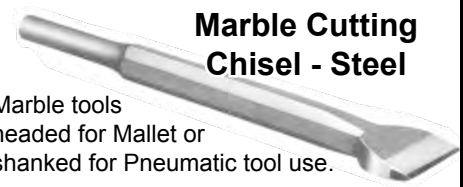

Marble tools headed for Mallet or shanked for Pneumatic tool use.

| Stock | Shank | Blade Width | Item # |
|-------|-------|-------------|-----------|
| 1/2" | 1/2" | 3" | 3302-0091 |

Hand Set - Steel



| Stock | Blade Width | Item # |
|--------|-------------|-----------|
| 1/2" | 3/4" | 2308-0007 |
| 1/2" | 1" | 2308-0008 |
| 1" | 2" | 2308-0010 |
| 1-1/8" | 2" | 2308-0013 |
| 1-1/8" | 2-1/2" | 2308-0001 |
| 1-1/8" | 3" | 2308-0002 |

Hand Chipper - Steel



| Stock | Blade Width | Item # |
|-------|-------------|-----------|
| 1/2" | 1" | 2303-0002 |
| 1" | 1-1/2" | 2303-0003 |

Hand Tracer - Steel



| Stock | Blade Width | Item # |
|--------|-------------|-----------|
| 1" | 1-1/2" | 2309-0013 |
| 1" | 2" | 2309-0002 |
| 1-1/8" | 2" | 2309-0003 |
| 1-1/8" | 2-1/2" | 2309-0004 |
| 1-1/8" | 3" | 2309-0005 |

G.C.T. Soft Stone Hand Carving Set



For working with marble or soft stone.

2310-0001

Set includes:

- **2 Flat Chisels** - 3/8" and 3/4" blade, both with 3/8" stock
- **2 Tooth Chisels** - 3/8" and 3/4" blade and 5 pointed teeth; 1/2" stock with 5/8" blade and 4 square teeth
- **1 Rondel Chisel** - 1/2" stock with 3/4" rondel blade
- **1 Point Chisel** - 1/2" stock
- **Tool Pouch** for easy storage
- 1-1/2 lb. Round Hammer (6" Handle)

Marble Frosting Tool - Steel



Use the Frosting Tool to leave a fine texture in marble or softer stone.

| Stock | Shank | Rows of Teeth | Teeth per Row | Item # |
|-------|-------|---------------|---------------|-----------|
| 3/4" | 1/2" | 8 | 8 | 3308-0003 |

Striking Hammer

Use with:
32" Wood or
32" Fiberglass

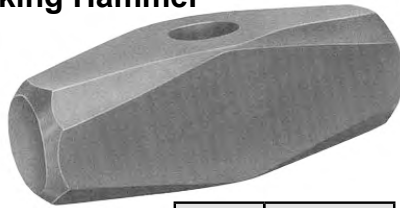

This is used to strike other hammers or wedges and shims. Not intended to strike stone. For best results, the Striking Hammer should be heavier than the hammer it is striking.

| Weight | Item # |
|--------|-----------|
| 6 lb | 2305-0021 |
| 8 lb | 2305-0017 |
| 10 lb | 2305-0024 |
| 12 lb | 2305-0027 |

Marble Bush Hammer

Use with:
16" Wood or
13" Fiberglass



For shaping, texturing, or smoothing soft stone. To shape or remove stone, use more impact. Lighter impact will smooth the stone, leaving a stippled finish.

| Stock | Length | Weight | Item # |
|--------|--------|----------|-----------|
| 1-1/2" | 6 | 3-1/2 lb | 2305-0028 |
| 1-3/4" | 6-1/2 | 5-1/2 lb | 2305-0031 |

Bull Set

Use with:
32" Wood or
32" Fiberglass



Sizes: 8, 10, or 12 lbs.
Steel or Carbide tip.

| Weight | Type | Item # |
|--------|------|-----------|
| 8 lb | C/T | 2305-0068 |
| 10 lb | C/T | 2305-0044 |
| 12 lb | C/T | 2305-0045 |

| Weight | Type | Item # |
|--------|-------|-----------|
| 8 lb | Steel | 2305-0080 |
| 10 lb | Steel | 2305-0038 |
| 12 lb | Steel | 2305-0041 |

Slab Splitter

Use with:
32" Wood or
32" Fiberglass

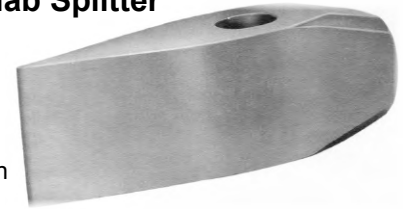

For splitting large blocks of stone. Using the Slab Splitter is a 2-person operation - one person holds the hammer angled on its edge, set in place along the line where the stone is to be split. The other person then hits it with the Striking Hammer.
Note: This hammer is not meant to be swung.

| Weight | Item # |
|--------|-----------|
| 10 lb | 2305-0036 |
| 12 lb | 2305-0039 |

Cutters Hand Hammer

Use with:
13" Wood or
13" Fiberglass



For striking hand tools or wedges and shims. Hammer is hardened for a more powerful blow and better wear.

| Weight | Item # |
|----------|-----------|
| 1 lb | 2305-0013 |
| 1-1/2 lb | 2305-0015 |
| 2 lb | 2305-0016 |
| 2-1/4 lb | 2305-0018 |

| Weight | Item # |
|----------|-----------|
| 2-1/2 lb | 2305-0020 |
| 2-3/4 lb | 2305-0022 |
| 3 lb | 2305-0023 |
| 4 lb | 2305-0029 |

Mash Hammer

Use with:
16" Wood or
13" Fiberglass



Made for striking stone only; should not be used to hit another hammer, nor be hit by another hammer. One end is a splitting blade for breaking stone; the other end is for trimming and can be provided with either a flat or concave face. Sizes: 3-16 lbs. 2, 3 & 4 lbs. available with carbide

| Weight | Item # |
|-------------|-----------|
| 4 lb | 2305-0026 |
| 4 lb, Carb. | 2305-0035 |
| 6 lb | 2305-0030 |
| 12 lb | 2305-0040 |

Use with: 16" Wood or
13" Fiberglass

The Stinger

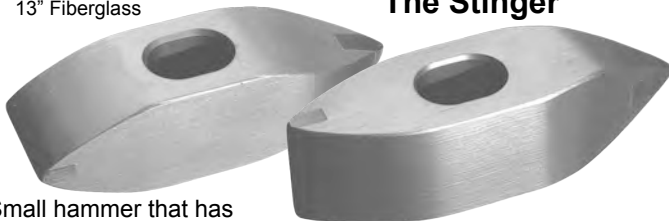

Small hammer that has carbide on both ends, a point on one and a chisel blade on the other for quick and easy pointing, chiseling, and splitting. It is available in either 2 or 4 lb. weight, with vertical or horizontal blade.

| Blade | Weight | Item # |
|------------|--------|-----------|
| Vertical | 2 lb | 2305-0011 |
| Horizontal | 2 lb | - |
| Vertical | 4 lb | - |
| Horizontal | 4 lb | - |

Double Blade Masons Hammer

Use with:
16" Wood or
13" Fiberglass

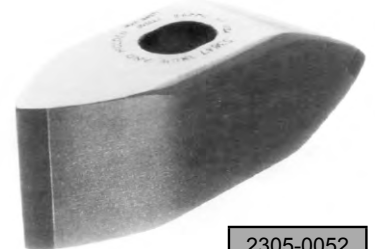

The 4lbs. Double Blade Mason's Hammer features the same heavy duty carbide-tipped blade as our Stone Buster, but gives you both a vertical and horizontal blade in one hammer. Whatever the job, this versatile hammer has the right blade.

2305-0052

Stone Buster

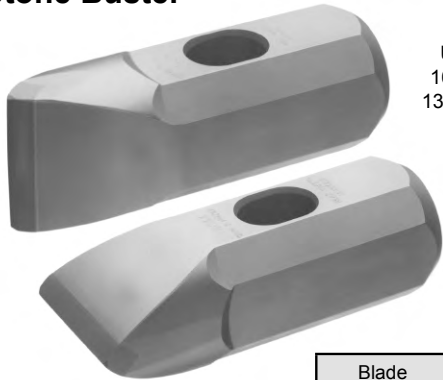

Use with:
16" Wood or
13" Fiberglass

Our 4 lbs. carbide-tipped bladed Stone Buster hammer can be used three different ways to handle a wide variety of stone cutting jobs.

| Blade | Item # |
|------------|-----------|
| Vertical | 2305-0048 |
| Horizontal | 2305-0070 |

Hammer Set

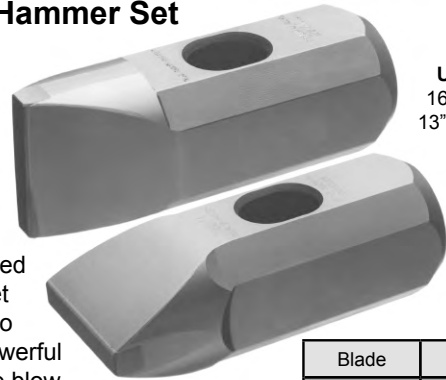

Use with:
16" Wood or
13" Fiberglass

Our 4lbs. carbide-tipped Hammer Set allows you to deliver a powerful yet accurate blow to make your edge work and pitching jobs go even faster. Just position the blade, then strike the heat-treated head with another hammer. Like our Stone Buster, the hammer head is also perfect for striking other hand tools.

| Blade | Item # |
|------------|-----------|
| Vertical | 2305-0050 |
| Horizontal | 2305-0051 |

Hickory Handles



Made of good, second growth hickory, without knots or defects in the wood. Hickory is a tough, springy wood. Does not burn the hands. Available for Hand, bush and striking hammers.

| Length | Item # |
|--------|-----------|
| 13" | 2305-0085 |
| 30" HD | 2305-0005 |

Fiberglass Handles



Longer lasting and stronger than the finest grade wooden handles. Shock absorbing handle and Cush-N-Grip handgrip provides maximum comfort. Available for: Hand, Bush and Striking Hammers.

| Length | Item # |
|-----------|-----------|
| 13" | 2305-0009 |
| 16" Temp. | 2305-0010 |
| 32" | 2305-0047 |



3901-0001

Included Equipment:

- JET STIK
- Propane regulator
- Hose bundle
- Hard-hat with visor
- Safety glasses
- 10 respirators
- Striker
- Instruction manual

JET STIK Stone Working Flame Tool

The JET STIK, with its 5,000 feet per second high velocity flame, is unsurpassed in giving you the control, speed and versatility you need when surfacing, carving, edging, sculpting, and texturing stone. It removes material rapidly without overheating, fracturing or fusing the stone. The JET STIK has dozens of uses such as: Edging granite countertops and building panels, restoring the non-slip surface on old steps, stone sculpting and even graffiti removal. Works great on: granite, sandstone, bluestone, dolomite limestone, or quartzite.



Customers have been so happy with the performance of our Comfort Grip hand tools that we have decided to offer a complete set. With our 3 lb. Hand Hammer, all in a sturdy canvas tool bag. Our Comfort Grip carbide hand tools feature contoured handles which provide a secure grip for more powerful blows. Heavier carbide tips last and last, even when cutting the hardest stone. All of our tools are manufactured from the highest quality American-made steel and carbide.

G.C.T. COMFORT GRIP COLLECTION

2310-0003



Included are:

- 3 lb. Hand Hammer with oval eye and larger striking face
- Heavy Hand Point with Comfort Grip handle
- Comfort Grip Hand Chisel with 1-1/4" heavy duty blade
- Comfort Grip Hand Set with 2" blade
- Comfort Grip Hand Tracer with 2" heavy duty blade
- Heavy duty canvas tool bag.

SoftStone Hammer



| Weight | Item # |
|----------|-----------|
| 1-1/2 lb | 2305-0055 |

These annealed (or unhardened) hammers produce a lighter blow, which can provide more control when working in softer stone. Excellent for lettering and detailing work, these SoftStone Hammers are also less likely to bruise the stone. Includes 10" wood handle.

Round Hand Hammer



| Weight | Item # |
|-----------|-----------|
| 1 lb | 2305-0058 |
| 1-1/2 lb | 2305-0059 |
| 2 lbs | 2305-0060 |
| 2-1/2 lbs | 2305-0061 |

Our new mallet-shaped Round Hand Hammer, like our Cutter's Hand Hammer, is hardened for more power and better wear. Round striking surface makes it easier to deliver a solid blow. Includes 6" hardwood handle.

Carbide Hammer Point



| |
|-----------|
| 2305-0053 |
|-----------|

The 4 lbs. carbide-tipped Hammer Point is the fast, easy way to rough out a block. It's also perfect for removing a difficult knot or high spot. You can swing the Hammer Point like a regular hammer or use the sturdy fiberglass handle to hold it in position while you strike it with another hammer. Keeping your hand away from the action allows you to deliver a powerful blow without fear of a miss-strike. This could be the most valuable tool in your toolbox. Weighs 4 lbs.

GCT Straight Edge



| Length | Item # |
|--------|-----------|
| 3'6" | 2509-0011 |
| 4'6" | 2509-0012 |
| 5'6" | 2509-0013 |

This clamp on straight edge is made with lead plugs to prevent damage to finished surfaces. The soft plugs may be renewed. Available without end pieces.

| Description | Item # |
|-------------|-----------|
| Lead Plug | 2509-0002 |

Straight Edge Grips



Eliminate need for clamp on end pieces. Make layout and chipping a one man operation. Suction pads grip blade securely*.

| | |
|----------|-----------|
| Set of 2 | 2509-0008 |
|----------|-----------|

*For use on polished surfaces

Green Silicon Grinding Wheels

Very sharp cool cutting wheels. Excellent for sharpening carbide tipped bits as well as non-ferrous materials such as aluminum, glass, ceramic, and cast iron.

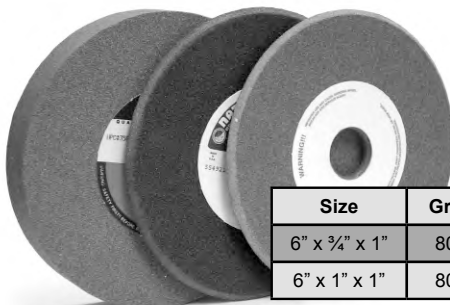

| Size | Grit | Item # |
|----------------|------|-----------|
| 6" x 3/4" x 1" | 80 | 1906-0064 |
| 6" x 1" x 1" | 80 | 1906-0063 |

Aluminum Oxide Grinding Wheels

Excellent general purpose wheel for routine use on bench grinders. Great for everyday shop use on various steels.



| Grit | Size | Item # |
|------|---------|-----------|
| 60 | 6" x 1" | 1906-0101 |

STC Bull Set Hammer (Steel)

with 30" wood handle

| Weight | Item # |
|--------|--------|
| 6 lb | 173906 |
| 8 lb | 173907 |
| 10 lb | 173908 |
| 12 lb | 173909 |



STC Mason Hammer

with 14" wood handle

| Weight | Item # |
|--------|--------|
| 2 lb | SMH2WH |
| 3 lb | SMH3WH |
| 4 lb | SMH4WH |



STC Bell Hammer

with 14" wood handle

| Weight | Item # |
|----------|--------|
| 1-1/2 lb | 173901 |
| 2 lb | 173902 |
| 2.5 lb | 173903 |
| 3 lb | 173904 |
| 3.5 lb | 173905 |

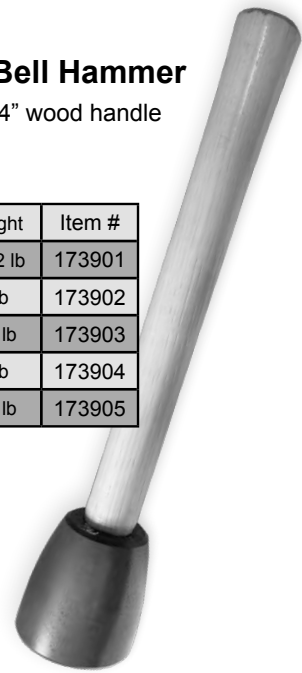

STC Mini Cleaver Hammer

with 14" wood handle

| Hand | Weight | Item # |
|-------|--------|--------|
| Right | 3 lb | MC3RH |
| Left | 3 lb | MC3LH |



STC Hand Hammer

with 13" fiber-g handle

| Weight | Item # |
|---------|---------|
| 1/2 lb | HH1/2 |
| 2 lb | HH2FGH |
| 2.5 lb | HH2-1/2 |
| 2.75 lb | HH2-3/4 |
| 3 lb | HH3FGH |
| 4 lb | HH4FGH |



STC Hand Chisels



| Shank | Blade | Item # |
|-------|-------|--------|
| 3/8" | 1/8" | 173915 |
| 3/8" | 1/4" | 173916 |
| 3/8" | 3/8" | 173917 |
| 1/2" | 1/2" | 173918 |
| 5/8" | 5/8" | 173919 |
| 3/4" | 3/4" | 173920 |
| 7/8" | 7/8" | 173921 |

STC Hand Tracer

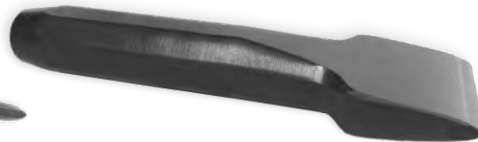

| Shank | Blade | Item # |
|--------|--------|--------|
| 7/8" | 1" | 173922 |
| 7/8" | 1 1/2" | 173923 |
| 1" | 2" | 173924 |
| 1 1/4" | 1 1/2" | 173925 |
| 1 1/4" | 2" | 173926 |
| 1 1/4" | 2 1/2" | 173927 |
| 1 1/4" | 3" | 173928 |
| 1 1/4" | 4" | 173929 |
| 1 1/4" | 6" | 173930 |

STC Hand Set



| Shank | Blade | Item # |
|--------|--------|--------|
| 7/8" | 1" | 173931 |
| 7/8" | 1 1/2" | 173932 |
| 1" | 2" | 173933 |
| 1 1/4" | 2" | 173934 |
| 1 1/4" | 2 1/2" | 173935 |
| 1 1/4" | 3" | 173936 |
| 1 1/4" | 4" | 173937 |

STC LINE

STC Hand Drive

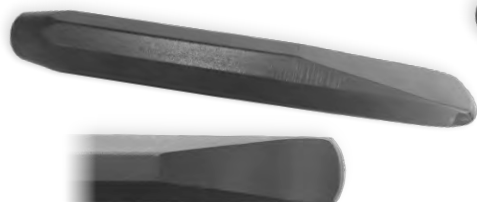

Top View

| Shank | Blade | Item # |
|--------|--------|--------|
| 1 1/8" | 1 1/8" | 173938 |

STC Monument Hand Chipper



| Shank | Blade | Item # |
|--------|--------|--------|
| 7/8" | 1" | 173940 |
| 7/8" | 1 1/2" | 173941 |
| 7/8" | 1 3/4" | 173942 |
| 7/8" | 2" | 173943 |
| 7/8" | 2 1/2" | 173944 |
| 7/8" | 3" | 173945 |
| 7/8" | 4" | 173946 |
| 1 3/4" | 3" | 173947 |
| 1 1/4" | 4" | 173948 |
| 1 1/4" | 6" | 173949 |

STC Masonry Hand Chipper



| Shank | Blade | Item # |
|-------|--------|--------|
| 7/8" | 1" | 173950 |
| 1" | 1 1/2" | 173951 |
| 1" | 1 3/4" | 173952 |
| 1" | 2" | 173953 |
| 1" | 3" | 173954 |



4-Point Tooth Chisel

| Stock | Shank | Item # |
|-------|-------|--------|
| 1/2" | 1/2" | 173966 |
| 1/2" | 5/8" | 173967 |
| 5/8" | 5/8" | 173968 |
| 1/2" | 3/4" | 173969 |
| 5/8" | 3/4" | 173970 |



9-Point Tooth Chisel

| Stock | Shank | Item # |
|-------|-------|--------|
| 1/2" | 3/8" | 173971 |
| 1/2" | 5/8" | 173972 |
| 1/2" | 3/4" | 173973 |



16-Point Tooth Chisel

| Stock | Shank | Item # |
|-------|-------|--------|
| 1/2" | 1/2" | 173974 |
| 1/2" | 3/4" | 173975 |
| 5/8" | 3/4" | 173976 |

STC Machine Chisels



| Shank | Blade | Item # |
|-------|-------|--------|
| 1/2" | 1/8" | 173955 |
| 1/2" | 3/16" | 173956 |
| 1/2" | 1/4" | 173957 |
| 1/2" | 3/8" | 173958 |
| 1/2" | 1/2" | 173959 |
| 1/2" | 5/8" | 173960 |
| 1/2" | 3/4" | 173961 |
| 5/8" | 5/8" | 173962 |

STC Machine Clean Up Chisels



| Shank | Blade | Item # |
|-------|--------|--------|
| 1/2" | 1" | 173963 |
| 1/2" | 1/4" | 173964 |
| 1/2" | 1 1/2" | 173965 |

STC Hand Point Chisels



| Shank | Tip | Item # |
|-------|------|--------|
| 3/8" | 3/8" | 173910 |
| 1/2" | 3/8" | 173911 |
| 5/8" | 3/8" | 173912 |
| 3/4" | 3/8" | 173913 |
| 7/8" | 3/8" | 173914 |

Air Sonic Mini-Pneumatic Die Grinder



1703-0006

*no warranty implied

This tool is the most powerful mini die grinder we have seen anywhere, yet is just slightly larger than a Pencil Grinder. It has more power to handle our 2" and 2-1/2" Diamond Blades. Comes with one collet that works for both 1/4" and 6mm shanks. Weighs only .99 of a lb. Powerful 12.4 CFM motor at 85psi. Runs at 35,000 RPM.

MD Pneumatic Die Grinder



1909-0222

- 6mm collet capacity
- Variable Speeds (30,000 RPM) for maximum production
- 90 PSI with 8-10 CFM
- Weighs less than a pound

metabo GA18LTX Cordless Die Grinder



Kit with grinder, 2 batteries & charger.

1703-0062

- No Load Speed: 25,000 rpm
- Collar diameter: 1.69"
- Battery pack voltage/cap. 18V/5.2 Ah
- Collet Diameter: 6mm
- Tool Weight: 4.6 lbs.

| Desc. | Item # |
|-------------|-----------|
| Grinder | 1703-0063 |
| Shaft | 1703-0060 |
| 2 Batteries | 1918-0125 |
| Charger | 1918-0126 |

Makita GD0601 Die Grinder



1 Year Limited Warranty

1703-0054

- 1/4" collet capacity
- Double insulated
- High speed (25,000 RPM) for maximum production
- 120 V, 3.5 AMP hi-tech motor
- Stepped neck of solid aluminum housing for added durability
- AC/DC switch for use with alternative power source

metabo GE710 Plus Die Grinder



1703-0059

- 1/4" collet capacity
- Aluminum die-cast gear housing
- 10,000 - 30,500 RPM
- 120 V, 6.4 AMP, 710 Watt
- Metabo Marathon motor with patented dust protection for long service life

Mounted Felt Bobs



Solid felt mounted on 1/4" shanks. The perfect buffer for small areas and detail polishing.

| # | Type | Item # |
|---|----------|-----------|
| 1 | CYLINDER | 4107-0003 |
| 2 | TAPERED | 4107-0002 |

Polishing 1/4" Cones



Resin bond diamond polishing cones are ideal for honing or polishing intricate shapes or hard to reach areas. 1-3/4" long x 1" wide, tapering to 3/8" with 1/4" shank.

| Grit | Item # |
|-------|-----------|
| #30 | 4109-0021 |
| #50 | 4109-0118 |
| #100 | 4109-0119 |
| #200 | 4109-0120 |
| #400 | 4109-0121 |
| #800 | 4109-0122 |
| #1500 | 4109-0023 |
| #3000 | 4109-0124 |
| Black | 4109-0024 |
| White | 4109-0025 |

Triatic Diamond Discs

- For Detail Polishing



Excellent for grinding and polishing granite, marble, glass, or composite materials. Triatic discs are designed for optimal performance and every grit is nickel plated diamond and does not require water.

| Grit | 1" | 2" |
|--------|-----------|-----------|
| #30 | 1904-0383 | 1904-0387 |
| #60 | 1904-0409 | 1904-0386 |
| #80 | 1904-0377 | 1904-0385 |
| #150 | 1904-0376 | 1904-0406 |
| #200 | 1904-0370 | 1904-0378 |
| #400 | 1904-0371 | 1904-0380 |
| #600 | 1904-0372 | 1904-0379 |
| #800 | 1904-0374 | 1904-0381 |
| #1800 | 1904-0373 | 1904-0382 |
| Backer | 4113-0151 | 4113-0002 |

Mounted Wheels

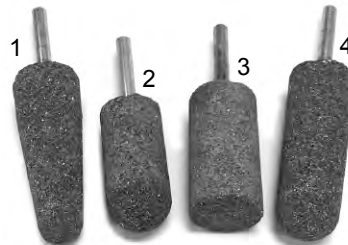

Silicon carbide mounted profile shapes. Ideally suited for rough grinding or reaming on all types of stone. 1/4" shank.

| # | Type | Item # |
|---|---------------|-----------|
| 1 | 3/4" x 2 1/2" | 1907-0001 |
| 2 | 7/8" x 2" | 1907-0003 |
| 3 | 1" x 2" | 1907-0011 |
| 4 | 7/8" x 2 1/2" | 1907-0005 |

Max 24,000 RPM

Sintered Diamond Sculpting Point 6mm Shaft

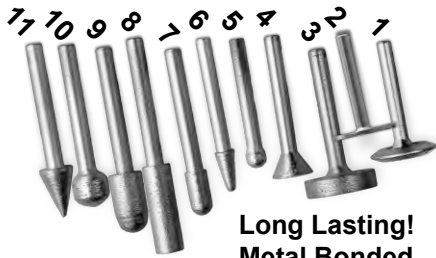

**Long Lasting!
Metal Bonded**

| # | Desc. | Item # |
|----|------------------|-----------|
| 1 | Knife Edge | 1912-0224 |
| 2 | Thin Blade | 1912-0225 |
| 3 | Wide Blade | 1912-0226 |
| 4 | Dove Tail | 1912-0227 |
| 5 | Small Ball | 1912-0228 |
| 6 | Taper | 1912-0229 |
| 7 | Small Sphere End | 1912-0230 |
| 8 | Cylinder | 1912-0231 |
| 9 | Large Sphere End | 1912-0232 |
| 10 | Large Ball | 1912-0233 |
| 11 | Cone Shape | 1912-0234 |

Diarex Profiling Bits

Recommended for use with pneumatic pencil grinders, ideal for sculpting & detailing. Sintered diamond for superior performance.



- 6mm connection shaft
- Use wet or dry

| # | Desc. | Item # |
|----|--------------------|--------|
| 16 | Milling Wheel | 115882 |
| 17 | 50mm Blade | 115819 |
| 18 | 25mm Blade | 103355 |
| 30 | 50mm Dry Cut Turbo | 115823 |



Electroplated 1/4" & 6 mm Shaft Die Grinder Tools

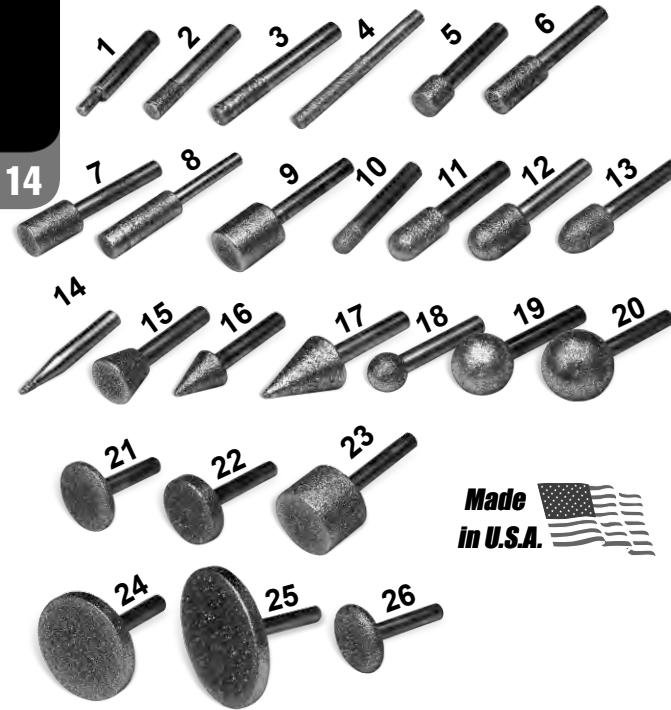

Made in U.S.A.

| Shaft | 30/40 Diamonds | | 50/60 Diamonds | | |
|-------------------------|----------------|-----------|----------------|-----------|-----------|
| | 1/4" | 6 mm | 1/4" | 6 mm | |
| Description | # | Item # | Item # | Item # | |
| 5/32" Dia Blunt x 3/8" | 1 | - | - | 1912-0064 | 1912-0090 |
| 1/4" Dia Blunt x 1/2" | 2 | 1912-0125 | 1912-0149 | 1912-0065 | 1912-0091 |
| 1/4" Dia Blunt x 3/4" | 3 | 1912-0126 | 1912-0150 | 1912-0066 | 1912-0092 |
| 1/4" Dia Blunt x 1 1/2" | 4 | 1912-0127 | 1912-0151 | 1912-0067 | 1912-0093 |
| 3/8" Dia Blunt x 3/8" | 5 | 1912-0128 | 1912-0152 | 1912-0068 | 1912-0094 |
| 3/8" Dia Blunt x 3/4" | 6 | 1912-0129 | 1912-0153 | 1912-0069 | 1912-0095 |
| 1/2" Dia Blunt x 3/4" | 7 | 1912-0130 | 1912-0154 | 1912-0070 | 1912-0096 |
| 1/2" Dia Blunt x 1 1/2" | 8 | 1912-0131 | 1912-0155 | 1912-0071 | 1912-0097 |
| 5/8" Dia Blunt x 3/4" | 9 | 1912-0132 | 1912-0156 | 1912-0072 | 1912-0098 |
| 1/4" Sphere End x 3/8" | 10 | 1912-0133 | 1912-0157 | 1912-0073 | 1912-0099 |
| 3/8" Sphere End x 3/4" | 11 | 1912-0134 | 1912-0158 | 1912-0074 | 1912-0100 |
| 1/2" Sphere End x 3/4" | 12 | 1912-0135 | 1912-0159 | 1912-0075 | 1912-0101 |
| 1/2" Bullet x 3/4" | 13 | 1912-0136 | 1912-0160 | 1912-0076 | 1912-0102 |
| Pointed | 14 | - | - | 1912-0077 | 1912-0103 |
| Dove Tail 5/8" Dia | 15 | 1912-0137 | 1912-0161 | 1912-0078 | 1912-0104 |
| Cone 1/2" Dia x 3/4" | 16 | 1912-0138 | 1912-0162 | 1912-0079 | 1912-0105 |
| Cone 3/4" Dia x 1 1/8" | 17 | 1912-0139 | 1912-0163 | 1912-0080 | 1912-0106 |
| 1/2" Dia Ball | 18 | 1912-0140 | 1912-0164 | 1912-0081 | 1912-0107 |
| 3/4" Dia Ball | 19 | 1912-0141 | 1912-0165 | 1912-0082 | 1912-0108 |
| 1" Dia Ball | 20 | 1912-0142 | 1912-0166 | 1912-0083 | 1912-0109 |
| 1" Dia x 1/8" Disc | 21 | 1912-0143 | 1912-0167 | 1912-0084 | 1912-0110 |
| 1" Dia x 1/4" Disc | 22 | 1912-0144 | 1912-0168 | 1912-0085 | 1912-0111 |
| 1" Dia x 3/4" Disc | 23 | 1912-0145 | 1912-0169 | 1912-0086 | 1912-0112 |
| 1-1/2" Dia x 1/4" Disc | 24 | 1912-0146 | 1912-0170 | 1912-0087 | 1912-0113 |
| 2" Dia x 1/4" Disc | 25 | 1912-0147 | 1912-0171 | 1912-0088 | 1912-0114 |
| 1" Dia x 1/4" Rad. Disc | 26 | 1912-0148 | 1912-0172 | 1912-0089 | 1912-0115 |

Diamond Profile Blades



| Size | Item # |
|--------|-----------|
| 3/4" | 1912-0046 |
| 1-1/4" | 1912-0047 |
| 1-1/2" | 1912-0048 |
| 2" | 1912-0049 |
| 2-1/4" | 1912-0050 |

Long lasting sintered metal bond diamond segments welded to a disc mounted on a 6mm shaft. Ideal for sculpting and making irregular cuts in stone.

Max 11,000 RPM **Must use wet**

Diamond Milling Wheel 6mm shank

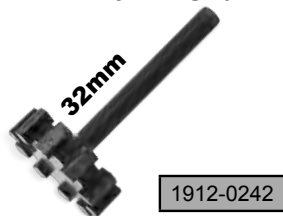

1912-0242

Diamond Brazed 14 Mounted Points



Set of
14 points.

1/4" Shaft.

1912-0201

14 popular shapes for all your sculpting or shaping needs. Utilizing brazing technology to plate the diamond makes for longer lasting tool.

DREMEL Engraver Stone Etching Tool

| | |
|-------------|-----------|
| Engraver | 1703-0046 |
| Diamond Tip | 1702-0016 |

120V, .2 Amps, 60 Hz
Weight 12 oz.
Strokes per minute 7,200 spm



1 Year Limited Warranty

Now you can make beautiful etchings in your own shop. By using a diamond tip bit in a variable-speed engraving tool, you can simply draw direct on a polished surface. Call and find out how inexpensive it is to get started.

Electric Engraver

| | |
|-------------|-----------|
| Engraver | 1703-0001 |
| Diamond Tip | 1702-0004 |

110V, .2 Amps, 60 Hz
Weight 6.4 oz.

Strokes per minute 3,600/7,200



GP-940 Pneumatic Stylus Pen Engraver

NEW



1/4" Inlet

1703-0064

2 cfm, 90 psi
Weight: 8.32 oz.
Stroke Speed : 34,000 bpm

The GP-940 Air Engraving Stylus is used to write on hard steel, metal, glass, stones, ceramic, plastics, etc. It is the ideal tool for artist etchings on black granite as the metal point is sharp and long lasting. The pneumatic tool will far outlast electric etchers and takes much longer to heat up. This tool is slender and much more ergonomic than any electric engraver. All this for slightly more money than an electric engraver which runs on a very small portable air compressor.

Diamond Points for Etching and Engraving Tools



Versatile diamond points, quantity discounts available

| Diamond Point Description | Item # |
|-------------------------------------|-----------|
| DREMEL 75 DEGREE 1/8x1 (WHITE) | 1702-0002 |
| DREMEL 90 DEGREE 1/8x1 (YELLOW) | 1702-0003 |
| ELECTRO STYLUS .060 X 5/8X90 POINTS | 1702-0004 |
| DREMEL 105 DEGREE 1/8x1 (BLUE) | 1702-0005 |
| Needle for Impact Etching Machines | 1702-0044 |

GP-940 Replacement Points

| | |
|--------|-----------|
| Fine | 1702-0051 |
| Medium | 1702-0052 |

Diamond Stone Etching Pens

| | |
|---------------|-----------|
| Pen | 1706-0002 |
| Refill | 1706-0001 |
| Pencil Stylus | 1706-0003 |



Electroplated 30 Diamond Profile Set



Electroplated diamond profile set for marble and composites.

30 Piece with 1/8" shank | 1912-0241

Foredom Engraver Tooling



For freedom engravers.

| | |
|--|-----------|
| BALL POINT, #3 F/Foredom Engraver 1.0mm | 1702-0011 |
| BALL POINT, #4 F/Foredom Engraver 1.4mm MEDIUM | 1702-0012 |
| BALL POINT, #5 F/Foredom Engraver 1.8mm LARGE | 1702-0013 |
| BALL POINT, #6 F/Foredom Engraver | 1702-0014 |

DIAMONDWRIGHT® Electroplated 1/8" Shaft Die Grinder Tools

Made in U.S.A.

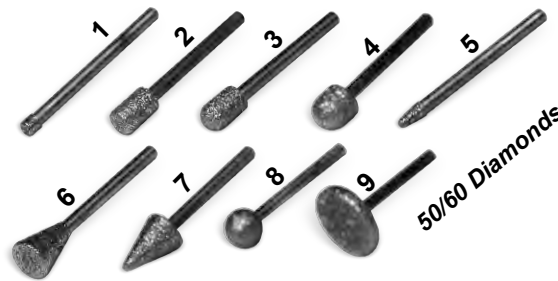

50/60 Diamonds

| Description | # | Item# |
|---------------------------|---|-----------|
| 5/32" Dia Blunt x 1/8" lg | 1 | 1912-0116 |
| 1/4" Blunt x 3/8" lg. | 2 | 1912-0117 |
| 1/4" Sphere end x 3/8" lg | 3 | 1912-0118 |
| 3/8" Sphere end x 3/8" lg | 4 | 1912-0119 |
| Pointed | 5 | 1912-0120 |
| Dove Tail 3/8" dia | 6 | 1912-0121 |
| Cone 3/8" dia x 9/16" lg | 7 | 1912-0122 |
| 3/8" dia Ball | 8 | 1912-0123 |
| 3/4" dia x 1/8" Disc | 9 | 1912-0124 |

Diamond Impact Etching Machines

DiamondEdge™ Sprinter

Etching Area: 23.6" x 15.7"

1709-0006

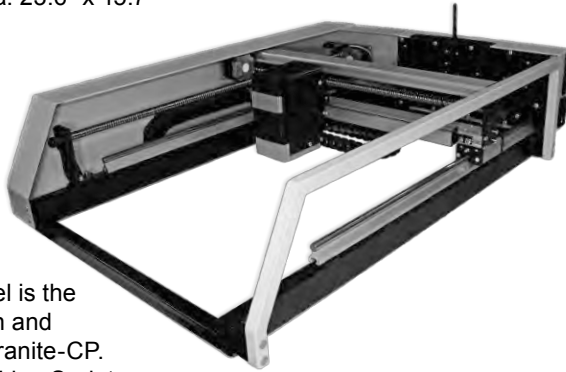

This New Model is the next generation and replaces the Granite-CP. This DiamondEdge Sprinter utilizes a completely new etching head that does not require use of a surface sensor, thus making use of the machine completely free of any adjustment operations. It is compact and portable but has an etching speed two times faster than the previous unit. Another new feature is the diamond tips are now held in place with a magnetic holder to make changing quick and wrench free.

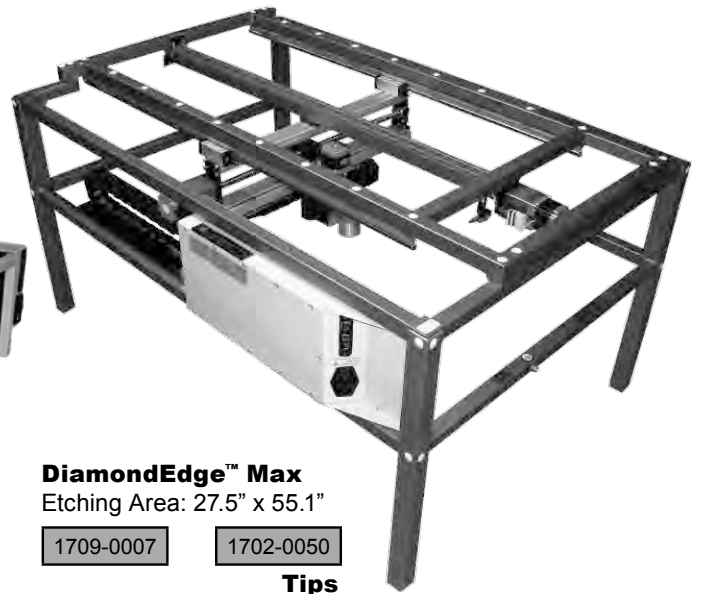

DiamondEdge™ Max

Etching Area: 27.5" x 55.1"

1709-0007

1702-0050

Tips

The next step in Mechanical etching machines. It has potential to get the job done faster and right the first time.

These machines also offer etching with ease, without having to level or position the stone "just right" you don't have to be perfect, the machine does most of it for you!



As close as it gets to manual etching without the tedious labor!



Image editing service available, starting at \$20.00. Ensures perfect quality.

2 YEAR WARRANTY!

Design Disc - 50 Ready Designs



1710-0001

DREMEL Lithium-Ion Cordless Rotary Tool Kit

Battery: Lithium-Ion Battery
Charge Time: 3 Hours
Speed: Variable (5,000 - 35,000 rpm)
Voltage: 10.8V DC
Weight: 14 oz

1703-0045

10.8V®



1 Year Limited Warranty

2 pack of extra batteries

99-679.5-0004

Extra battery charger

99-679.5-0005

DREMEL Digital Variable Speed Rotary Tool

Amperage: 1.6 amps
Cord Length: 6 ft.
Speed: Variable (5,000 to 35,000 RPM)
Voltage: 120 AC, 50-60 Hz
Tool Weight: 18.8 oz

1703-0058

1 Year Limited Warranty



Makita HR2475 1" Rotary Hammer



- 2X faster drilling with synchronized RPM and BPM
- Lighter and more powerful than any hammer in its class
- 3-mode operation; "rotation only", "hammering with rotation" or "hammering only"

Makita HR2811F 1-1/8" Rotary Hammer

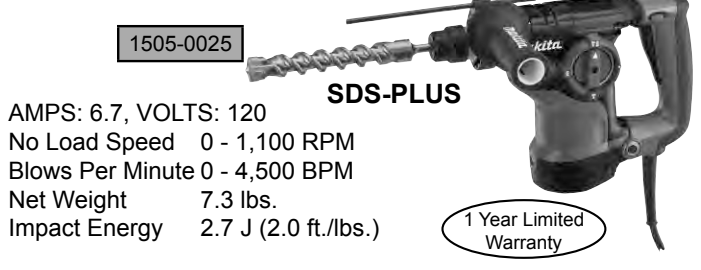

- L.E.D. Light Illuminates Drilling Surface
- 3-Mode Operation: Rotation Only & Hammering
- Recessed Lock-on button for continuous use
- "No Hammering When Idling" function ensures extra-low vibration under no load

Makita HR4041C 1-9/16" Rotary Hammer



- Electronic variable speed control dial (230 - 460 RPM) for easier hole starts
- LED light indicates when to replace carbon brushes and if there's a problem with the switch or power source
- Ball clutch torque limiter ensures stable torque control

metabo KHA36 3/4" Cordless Rotary Hammer



CRD-30 Rock Drill

Model CRD-30, a light weight sinker drill of 29 lbs. Will drill holes in soft and medium stone to 6 feet.

Weight: 29lbs - Length: 19-1/2"
 Cyl.Bore: 2-7/16" - Stroke: 1-7/16"
 Free Air: 81 CFM - 85 PSI
 Blows: 3,300 BPM
 Rotations: 270 RPM
 Air Inlet: 3/4" NPT Male

Specify Shank
 7/8" Hex x 3/4", 7/8" Hex x 4/4"

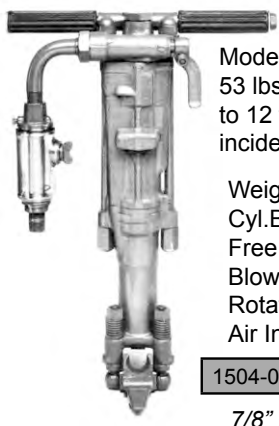

CRD-55 Rock Drill

Model CRD-55, a medium weight sinker drill of 53 lbs., will drill holes in medium and hard stone to 12 feet. A new 4-pawl design provides a higher incidence of blows for fast penetration.

Weight: 55lbs - Length: 23-13/17"
 Cyl.Bore: 2-5/8" - Stroke: 32-11/16"
 Free Air: 113 CFM - 85 PSI
 Blows: 1,950 BPM
 Rotations: 200 RPM
 Air Inlet: 3/4" NPT Male

Specify Shank
 7/8" Hex x 3/4", 7/8" Hex x 4/4", 1" Hex x 4/4"

Rotary Rock Drill

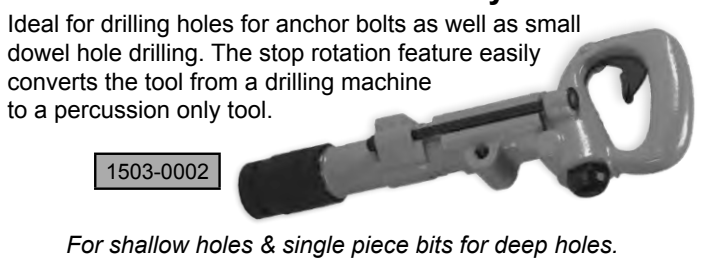

Chuck Size: 3/4" ROUND x 3-3/4"
 Bore diameter: 1-1/4"
 Stroke: 1"
 BPM: 3400
 CFM at 90psi: 19-21
 Weight: 9 lbs
 Length: 15"
 Air Inlet Size: 3/8" Female NPT

Whirly Plug Drill Bits

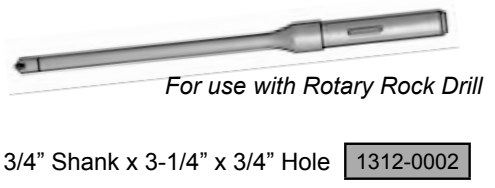

Call for other sized bits and more information.

Hollow Steel Plug Drill Bit



| Plug Bit Shank Size |
|---------------------|
| 3/4" x 4 - 1/4" |
| 3/4" x 3 - 1/4" |
| 7/8" x 3 - 1/4" |
| 7/8" x 4 - 1/4" |
| 1" x 4 - 1/4" |

| Plug Bits | | | |
|-----------|--------------|-----------|--------------|
| Hole Size | Under Collar | Hole Size | Under Collar |
| 5/8" | 6" | 1" | 24" |
| 5/8" | 9" | 1 - 1/8" | 9" |
| 5/8" | 14" | 1 - 1/8" | 14" |
| 3/4" | 6" | 1 - 1/8" | 20" |
| 3/4" | 9" | 1 - 1/8" | 24" |
| 3/4" | 14" | 1 - 1/4" | 9" |
| 3/4" | 20" | 1 - 1/4" | 14" |
| 3/4" | 24" | 1 - 1/4" | 20" |
| 7/8" | 6" | 1 - 1/4" | 24" |
| 7/8" | 9" | 1 - 3/8" | 9" |
| 7/8" | 14" | 1 - 3/8" | 14" |
| 7/8" | 20" | 1 - 3/8" | 20" |
| 7/8" | 24" | 1 - 3/8" | 24" |
| 1" | 6" | 1 - 1/2" | 9" |
| 1" | 9" | 1 - 1/2" | 14" |
| 1" | 14" | 1 - 1/2" | 20" |
| 1" | 20" | 1 - 1/2" | 24" |

Use in lightweight rock drills with 3/4", 7/8", or 1" hexagon shanks.

Adapter Type Drills



For Model 4105, Handi-drill, Taper adapters. Carbide Tipped

| Item # | Description |
|-----------|--|
| 1303-0011 | 5/16" x 2-1/4"DD x 4-3/8"L Taper Shank |
| 1303-0017 | 5/16" x 4-1/2"DD x 6-1/2"L Taper Shank |
| 1303-0006 | 3/8" x 2"DD x 4-3/8"L Taper Shank |
| 1303-0013 | 3/8" x 4-1/2"DD x 6-1/2"L Taper Shank |
| 1303-0014 | 7/16" x 2-1/4"DD x 4-3/8"L Taper Shank |
| 1303-0001 | 7/16" x 4-1/2"DD x 6-1/2"L Taper Shank |
| 1303-0002 | 1/2" x 2-1/4"DD x 4-3/8"L Taper Shank |
| 1303-0004 | 1/2" x 4-1/2"DD x 6-1/2"L Taper Shank |
| 1303-0007 | 1/2" x 6.5"DD x 8.5"L Taper Shank |
| 1303-0003 | 5/8" x 3.5"DD x 5"L Taper Shank |
| 1303-0008 | 5/8" x 4-1/2"DD x 6-1/2"L Taper Shank |
| 1303-0019 | 5/8" x 6-1/2"DD x 8-1/2"L Taper Shank |
| 1303-0012 | 3/4" x 4-1/2"DD x 6-1/2"L Taper Shank |
| 1303-0015 | 3/4" x 8"L Taper Shank |
| 1303-0010 | 7/8" x 4-1/2"DD x 6-1/2"L Taper Shank |
| 1303-0016 | 1" x 4-1/2"DD x 6-1/2"L Taper Shank |

Collard Shank Drill Steel



Available in 7/8" and 1" Hex. Shank with tool retainer collar. Bit thread sizes E, H & D Thread. Length under collar from 1' to 10'.

| | |
|-----------|---------------------------|
| 1302-0017 | 24" X 4-1/4" X 7/8" H-THR |
| 1302-0027 | 48" x 4-1/4" x 7/8" H-THR |
| 1302-0028 | 24" x 4-1/4" x 1" H-THR |
| 1302-0030 | 36" x 4-1/4" x 1" H-THR |
| 1302-0042 | 72" x 4-1/4" x 1" H-THR |

Carbide Insert Bits



| | |
|-----------|------------------------------|
| 1305-0007 | DEEP ROK H THREAD 1-3/8" |
| 1305-0006 | DEEP ROK H THREAD 1-1/2" |
| 1305-0012 | DEEP ROK H-THREAD 2" ROK |
| 1305-0008 | ECON ROK H THREAD 2" 4PT ROK |

These four point cross bits have one center hole and two side holes for clearing dust and debris while drilling. Available in standard and economy style. Sizes from 1 1/4" to 3" diameter.



Hard Tip Drill Bits Straight shank for air hammer with air hole thin center.

| | | | |
|-----------|--------------------------|-----------|-------------------------|
| 1307-0003 | 1/2" x 5/16" x 2-3/4" DD | 1307-0008 | 1/2" x 7/8" x 4" DD |
| 1307-0004 | 1/2" x 3/8" x 2-3/4" DD | 1307-0009 | 1/2" x 1" x 4" DD |
| 1307-0005 | 1/2" x 1/2" x 3" DD | 1307-0010 | 5/8" x 1/2" x 2-1/2" DD |
| 1307-0006 | 1/2" x 5/8" x 3" DD | 1307-0011 | 5/8" x 5/8" x 3" DD |
| 1307-0007 | 1/2" x 3/4" x 4" DD | 1307-0012 | 5/8" x 3/4" x 4-1/2" DD |

SDS-Plus Drill Bits (Slotted Shank)



Carbide-Tipped drills available from 5/32" - 1" diameter sizes.



| Item # | Size |
|-----------|----------------------|
| 1315-0006 | 5/32" x 6-1/2" |
| 1315-0002 | 3/16" x 4" x 2" |
| 1315-0004 | 3/16" x 6" x 4" |
| 1315-0007 | 7/32" x 6" x 4" |
| 1315-0015 | 7/32" x 9" x 7" |
| 1315-0018 | 7/32" x 12" x 10" |
| 1315-0001 | 1/4" x 4" x 2" |
| 1315-0003 | 1/4" x 6" x 4" |
| 1315-0009 | 1/4" x 8" x 6" |
| 1315-0012 | 9/32" x 6" x 4" |
| 1315-0011 | 5/16" x 6-1/4" x 4" |
| 1315-0017 | 5/16" x 8" x 6" |
| 1315-0005 | 3/8" x 6" x 4" |
| 1315-0020 | 3/8" x 8" x 6" |
| 1315-0034 | 3/8" x 22" x 19 1/2" |
| 1315-0019 | 7/16" x 6" x 4" |
| 1315-0013 | 1/2" x 6" x 4" |

| Item # | Size |
|-----------|---------------------|
| 1315-0025 | 1/2" x 8" x 6" |
| 1315-0027 | 1/2" x 12" x 10" |
| 1315-0033 | 1/2" x 18" x 16" |
| 1315-0039 | 1/2" x 24" x 22" |
| 1315-0022 | 9/16" x 6-1/2" x 4" |
| 1315-0028 | 9/16" x 12" x 10" |
| 1315-0026 | 5/8" x 6" x 4" |
| 1315-0030 | 5/8" x 9-1/2" x 7" |
| 1315-0044 | 5/8" x 18" x 16" |
| 1315-0047 | 5/8" x 24" x 22" |
| 1315-0036 | 3/4" x 7" x 9-1/2" |
| 1315-0042 | 3/4" x 12" x 10" |
| 1315-0048 | 3/4" x 18" x 16" |
| 1315-0046 | 7/8" x 12" x 10" |
| 1315-0050 | 7/8" x 18" x 16" |
| 1315-0049 | 1" x 18" x 15-1/2" |
| 1315-0051 | 1" x 18" x 16" |

SDS-MAX Drill Bits (Large Slotted Shank)



Carbide-Tipped drills available from 5/8" to 2" diameter sizes.



| Item # | Description |
|-----------|-------------------------|
| 1315-0084 | 1/2" x 7-1/4" x 13-1/2" |
| 1316-0001 | 5/8" x 13-1/2" x 7-1/2" |
| 1316-0013 | 5/8" x 21" x 16" |
| 1316-0003 | 3/4" x 17" x 11" |
| 1316-0004 | 7/8" x 17" x 11-1/2" |
| 1316-0012 | 1" x 13" x 8" |
| 1316-0006 | 1" x 18" x 13-3/8" |
| 1316-0005 | 1-1/4" x 15" x 10" |
| 1316-0019 | 1-1/2" x 17" x 12" |

Spline Shank Drill Bits



Carbide-tipped drills available from 3/8" to 1-1/2" diameter sizes.



| Item # | Size |
|-----------|-----------------------|
| 1317-0015 | 3/8" x 10" x 4" |
| 1317-0026 | 3/8" x 13" x 8" |
| 1317-0024 | 1/2" x 19-1/2" X 16" |
| 1317-0027 | 1/2" x 13" x 7" |
| 1317-0001 | 5/8" x 7" x 13" |
| 1317-0020 | 5/8" x 16" x 11" |
| 1317-0036 | 3/4" x 16" x 9-1/2" |
| 1317-0022 | 3/4" x 16" x 11" |
| 1317-0017 | 7/8" x 16" x 11" |
| 1317-0018 | 1" x 13" x 8" |
| 1317-0004 | 1" x 16" x 11" |
| 1317-0005 | 1" x 22" |
| 1317-0025 | 1-1/4" x 16" x 9-1/2" |
| 1317-0013 | 1-1/4" x 22" x 17" |
| 1317-0009 | 1-3/8" x 13" x 8" |
| 1317-0014 | 1-1/2" x 23" x 18" |

- No licenses or permits required
- Three-year shelf life
- One product for all temperatures
- Always wear safety goggles when using Betonamit!



Betonamit STONE SPLITTING POWDER

Betonamit non-explosive cracking agent is a non-toxic powder. When mixed with water and poured into holes of 1-1/4", 1-3/8", or 1-1/2" diameter, it hardens and expands, exerting pressures of 12,000 psi.

1018-0001



Stone Splitting Wedge and Shims Sets

Wedges and shims have been used for eons in the stone industry and are still among the most effective tools for splitting stone.

*Diameter of hole given is smallest hole these can be used in. Wedges and Shims can be used in holes 1/4" larger than listed. Special sizes to order.

Set includes: 1 wedge & 2 shims.

| Hole | Length | Type | Item # | Hole | Length | Type | Item # |
|--------|--------|------|-----------|--------|--------|------|-----------|
| 3/8" | 2-1/2" | Set | 2311-0029 | 1-1/4" | 10" | Set | 2311-0013 |
| 1/2" | 2-3/4" | Set | 2311-0030 | 1-1/2" | 12" | Set | 2311-0014 |
| 5/8" | 3" | Set | 2311-0031 | 1-1/2" | 18" | Set | 2311-0015 |
| 3/4" | 4" | Set | 2311-0032 | 1-1/2" | 24" | Set | 2311-0016 |
| 7/8" | 5" | Set | 2311-0033 | 1-1/2" | 36" | Set | 2311-0017 |
| 1" | 6" | Set | 2311-0011 | 1-1/2" | 48" | Set | 2311-0018 |
| 1-3/8" | 8" | Set | 2311-0012 | 2" | 12" | Set | 2311-0024 |

1. Drill holes along your split line at least as deep as your wedges are long and about 6" apart. For difficult splits, drill holes deeper and closer together. Your split line may be straight or curved.
2. Insert wedges and shims into holes as illustrated. Make sure the "ears" face the direction you want your stone to split.
3. Strike the wedges in sequence, firmly but without forcing. Wait a few minutes. Repeat until stone splits (clear the way).

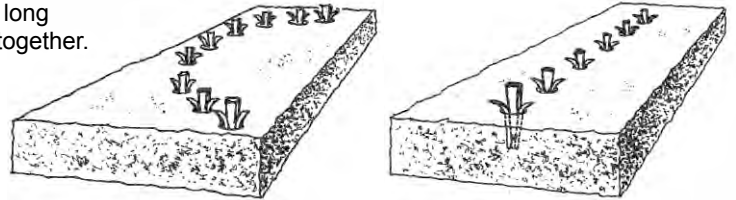

Bush Hammer



For radial arm machines

Developed by Park industries for use on their Wizard Radial Arm Polisher. Designed to hammer the surface for a leathered like or rough textured finish.

12" Frankfurt Polishing Plate

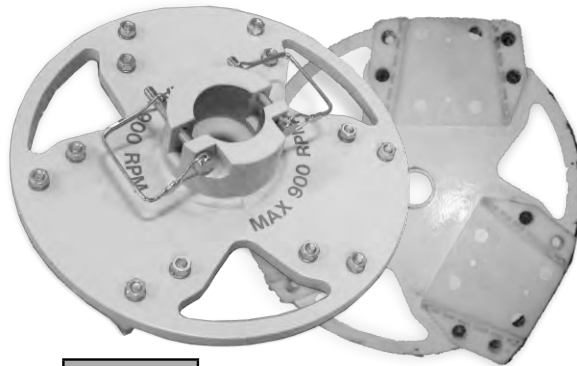

99-PI-0003

Radial arm frankfurt style diamond or abrasive brush wheel with holders. Developed for Park Wizard Machine.

J HOOK BALL ADAPTER to 5/8-18 Male



99-PI-0002

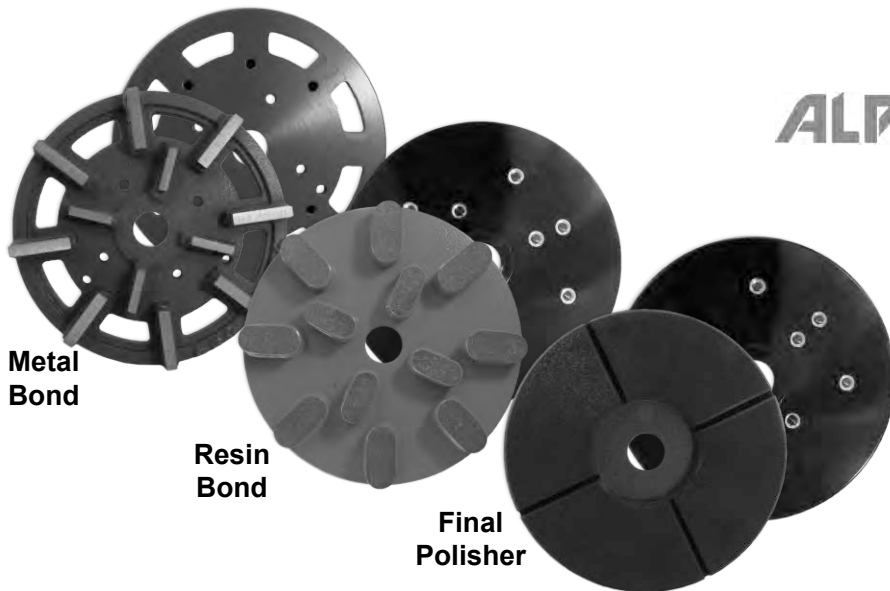

Metal Bond

Resin Bond

Final Polisher

ALPHA[®] Summit Wheels

| Grit | 6" | 8" | 10" |
|------------------------|-----------|-----------|-----------|
| Metal Bond | | | |
| #50 | - | 4114-0190 | 4114-0185 |
| #80 | 4114-0194 | 4114-0139 | 4114-0198 |
| #200 | 4114-0195 | 4114-0184 | 4114-0149 |
| #400 | 4114-0196 | 4114-0197 | 4114-0199 |
| Resin Bond | | | |
| #200 | 4114-0133 | 4114-0136 | 4114-0135 |
| #500 | 4114-0131 | 4114-0129 | 4114-0130 |
| #1000 | 4114-0141 | 4114-0140 | 4114-0144 |
| #2000 | 4114-0132 | 4114-0137 | 4114-0145 |
| #3000 | 4114-0142 | 4114-0143 | 4114-0146 |
| Final Polishers | | | |
| Buff | 4114-0161 | 4114-0167 | 4114-0134 |
| White Buff | 4114-0183 | 4114-0191 | 4114-0150 |

Alpha's three part system redefines the meaning of production. Heavy duty metal-bond grits remove deep scratches evenly so you can work on the back side of slabs or sawn surfaces on monumental blocks. Then sleek resin-bond grits put an unparalleled degree of polish. Final polisher brings that beautiful inherent color and reflection.

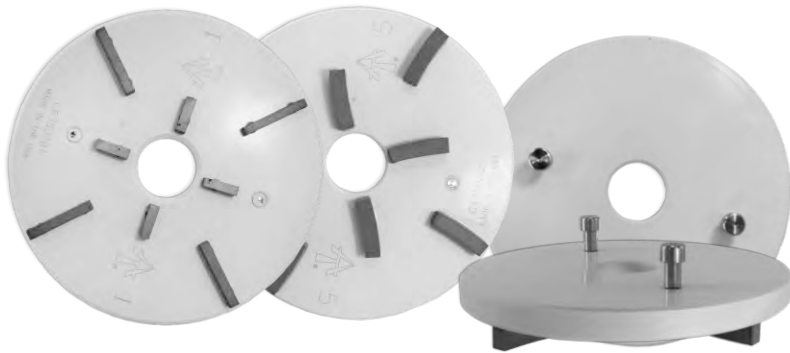
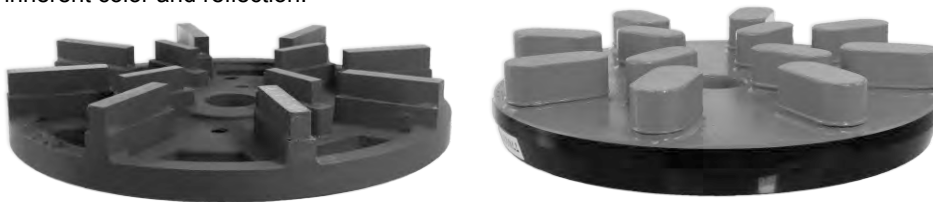

abrasive technology Slabmaster[™] Radial-Arm System

The Slabmaster[™] brand system is a quick, cost effective solution to the problem of retrofitting a radial arm machine with a diamond polishing system. All that is needed is for you to drill 2 holes in your existing drive head. This system will enable the machine operator to produce a top quality finish (factory or better) on granite and marble much faster and easier than by using bricks.

| 8", Granite Only | | 10", Granite/Marble Only | |
|------------------|-----------|--------------------------|-----------|
| Grit | Item # | Grit | Item # |
| #1 | 4114-0061 | #1 | 4114-0200 |
| #2 | 4114-0062 | #2 | 4114-0070 |
| #3 | 4114-0063 | #3 | 4114-0076 |
| #4 | 4114-0064 | #4 | 4114-0077 |
| #5 | 4114-0065 | #5 | 4114-0071 |
| #6 | 4114-0066 | #6 | 4114-0072 |
| Buff | 4114-0067 | Buff | 4114-0159 |
| | | White | 4114-0201 |

abrasive technology **Straight-Edge[™]**

For polishing straight edges, the Straight-Edge[™] (with snail-lock) brand diamond discs deliver a better finish with fewer passes than any other tool. Ideal for edges 3/4" or thicker, they eliminate scratches and leave a perfectly flat, polished edge.

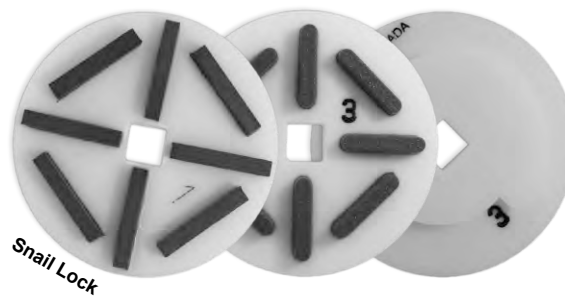

| Grit | 4" (14mm) |
|-------------|-----------|
| 1 | 4115-0001 |
| 2 | 4115-0021 |
| 3 | 4115-0022 |
| 4 | 4115-0023 |
| Buff | 4115-0024 |



DONGSIN 10" RESIN Top Polishing Discs

Engineered for smooth operation while top polishing granite, marble and engineered stone surfaces.

- Connection for Park Wizard

| Grit | 10" |
|------|--------|
| #50 | 122803 |
| #100 | 122790 |
| #200 | 122791 |
| #300 | 122792 |
| #400 | 122793 |
| #500 | 122794 |
| #600 | 122795 |
| #800 | 122796 |

| Grit | 10" |
|-------|--------|
| #1000 | 122797 |
| #1500 | 122798 |
| #2000 | 122799 |
| #3000 | 122800 |
| #6500 | 122801 |
| Black | 122771 |
| Gray | 123086 |
| White | 123087 |



DONGSIN 10" METAL Top Polishing Discs

Engineered for grinding and top polishing with high quality finish on Granite, Marble & Engineered Stone Surfaces.

- Connection for Park Wizard

| Grit | 10" |
|------|--------|
| #30 | 122932 |
| #50 | 122931 |
| #100 | 122925 |
| #200 | 122926 |
| #400 | 122927 |

Antiquing Brush Wheels Snail Lock and 5/8-11" Connections

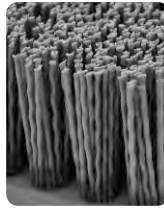
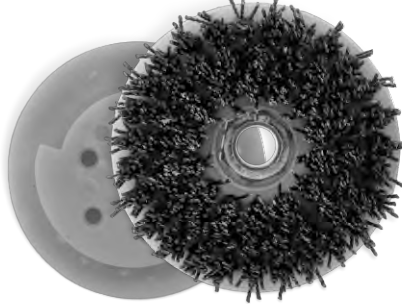

Every grit has a specific color to make it easy to distinguish and recognize.

- Nylon and Silicon Carbide abrasive filaments.
- This brush has a large number of filaments.
- Increased flexibility offers increased productivity.
- Available in a wide range of grains, it is possible to obtain from an opaque finishing to a mirror polishing.
- Unlimited shelf life.
- Recommended Speed: 2,000 r.p.m.
- Maximum Speed: 4,000 r.p.m.

| Grit | 4" |
|------|-----------|
| #24 | 4119-0153 |
| #36 | 4119-0154 |
| #46 | 4119-0155 |
| #60 | 4119-0156 |
| #80 | 4119-0157 |
| #120 | 4119-0158 |
| #180 | 4119-0159 |
| #240 | 4119-0160 |
| #320 | 4119-0161 |
| #500 | 4119-0211 |

Frankfurt Antiquing Brushes

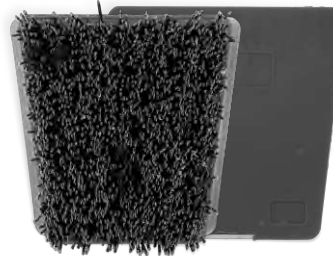

| Grit | Item# |
|------|-----------|
| #36 | 4119-0194 |
| #46 | 4119-0195 |
| #60 | 4119-0196 |
| #120 | 4119-0197 |
| #180 | 4119-0198 |
| #240 | 4119-0199 |
| #320 | 4119-0200 |
| #500 | 4119-0201 |

Fickert Antiquing Brushes



| Grit | Item# |
|------|-----------|
| #36 | 4119-0264 |
| #120 | 4119-0352 |
| #180 | 4119-0257 |
| #240 | 4119-0353 |
| #320 | 4119-0354 |
| #500 | 4119-0355 |

Leather Finishing Wheels Snail Lock and 5/8-11" Connections



Every grit has a specific color to make it easy to distinguish and recognize.

- Leather finishing: made of resin and diamond powder inside the filament.
- Designed to work with minimal pressure giving increased life while staying sharp.
- Allow an increased speed belt for more production and fewer steps.

Best used on granites, low pressure.
Call a rep. for setup details.

| Grit | 4" | 5" |
|------|-----------|-----------|
| #36 | 4119-0212 | 4119-0218 |
| #60 | 4119-0213 | 4119-0220 |
| #120 | 4119-0214 | 4119-0223 |
| #180 | 4119-0215 | 4119-0224 |
| #240 | 4119-0216 | 4119-0226 |

Frankfurt Leather Brushes

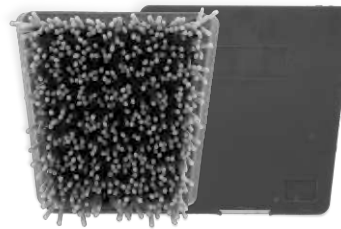

| Grit | Item# |
|------|-----------|
| #36 | 4119-0230 |
| #46 | 4119-0231 |
| #60 | 4119-0232 |
| #80 | 4119-0233 |
| #120 | 4119-0235 |
| #180 | 4119-0236 |
| #240 | 4119-0238 |
| #320 | 4119-0240 |
| #500 | 4119-0241 |

Fickert Leather Brushes

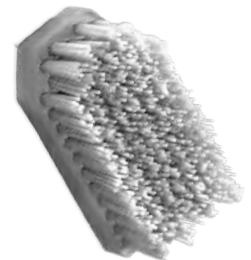

| Grit | Item# |
|------|-----------|
| #36 | 4119-0339 |
| #46 | 4119-0340 |
| #60 | 4119-0341 |
| #80 | 4119-0342 |
| #120 | 4119-0343 |
| #240 | 4119-0344 |
| #320 | 4119-0345 |
| #500 | 4119-0346 |

Antiquing Snail Lock Brushes

Diamond tool that gives an antique effect and enhances the natural color. Suitable for machines working on marble, and stones.



FilliFlex

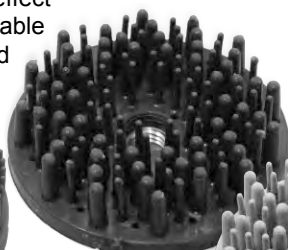

AirFlex

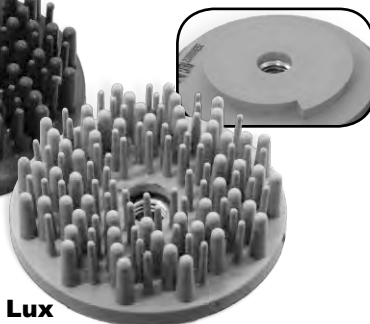

AirFlex Lux

5/8-11" Connection only on 4"

| Grit | Type | 4" | 5" |
|------|-------------|-----------|-----------|
| 36 | FilliFlex | 4119-0178 | 4119-0139 |
| 46 | FilliFlex | 4119-0179 | 4119-0140 |
| 60 | FilliFlex | 4119-0180 | 4119-0141 |
| 120 | AirFlex | 4119-0004 | 4119-0010 |
| 220 | AirFlex | 4119-0005 | 4119-0011 |
| 300 | AirFlex LUX | 4119-0181 | 4119-0171 |
| 400 | AirFlex LUX | 4119-0183 | 4119-0172 |
| 600 | AirFlex LUX | 4119-0184 | 4119-0173 |
| 800 | AirFlex LUX | 4119-0185 | 4119-0174 |



INNOVATIVE SOLUTIONS FOR THE PROCESSING OF NATURAL STONE, GRANITE, MARBLE AND ENGINEERED STONE!

Adria frankfurt bricks are the industry standard. These bricks are the highest quality supplied worldwide for decades by Adria.

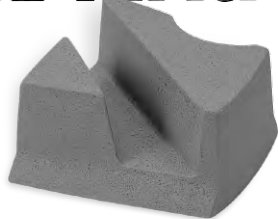

Adria
Frankfurt Bricks
For Marble



Adria
Frankfurt Bricks
For Granite

Soft Bond

| | Grit | Item# |
|--------|------|-----------|
| Grind | #36 | 4120-0116 |
| | #46 | 4120-0117 |
| | #60 | 4120-0118 |
| Hone | #80 | 4120-0119 |
| | #120 | 4120-0120 |
| | #180 | 4120-0121 |
| | #220 | 4120-0122 |
| | #320 | 4120-0123 |
| Polish | #400 | 4120-0347 |
| | #600 | 4120-0348 |
| | #800 | 4120-0349 |

Medium Bond

| | Grit | Item# |
|--------|------|-----------|
| Grind | #36 | 4120-0212 |
| | #46 | 4120-0213 |
| | #60 | 4120-0214 |
| Hone | #80 | 4120-0215 |
| | #120 | 4120-0216 |
| | #180 | 4120-0350 |
| | #220 | 4120-0217 |
| | #320 | 4120-0218 |
| Polish | #400 | 4120-0155 |
| | #600 | 4120-0156 |
| | #800 | 4120-0157 |

Medium Bond

| | Grit | Item# |
|--------|-------|-----------|
| Grind | #46 | 4120-0187 |
| | #60 | 4120-0188 |
| | #80 | 4120-0189 |
| Hone | #120 | 4120-0190 |
| | #180 | 4120-0191 |
| | #220 | 4120-0192 |
| | #320 | 4120-0193 |
| | #400 | 4120-0194 |
| Polish | #600 | 4120-0195 |
| | #800 | 4120-0196 |
| | #1000 | 4120-0197 |

Honing For Granite

This final granite honing brick will produce a uniform finish while eliminating shading. This final honing step draws out the color in honed granite. Two grits available.

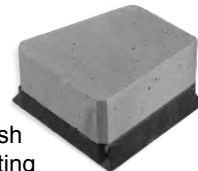

| | | |
|------|------|-----------|
| Hone | #220 | 4120-0184 |
| | #320 | 4120-0185 |

Honing For Marble



The final step in honing marble. Will leave the stone with a consistent beautiful finish.

HONE 4120-0186

5X Extra Marble Buff



5 Extra final step for polishing marble.

4120-0158

Marble White Cleaner



A solid shape for removing residue and add a shine.

4120-0199

Granite Buff



Final step for polishing granite.

4120-0198

Adria Hybrid Diamond Resin

These new resin frankfurt bricks are universal, use on granite, marble & engineered stone. The bricks will polish every stone well, but are also customizable to your specific application.



THE NEXT GENERATION IN TECHNOLOGY!

| | Grit | Item# |
|-------|--------------|-----------|
| Grind | Metal Coarse | 4120-0250 |
| | Metal Fine | 4120-0251 |
| | #60 | 4120-0252 |
| Hone | #80 | 4120-0253 |
| | #120 | 4120-0254 |
| | #220 | 4120-0255 |

| Polish | #320 | 4120-0256 |
|--------|-------|-----------|
| | #400 | 4120-0257 |
| | #600 | 4120-0258 |
| | #1500 | 4120-0259 |
| | #3000 | 4120-0260 |

Solid Felt 5" Buffers

Buffers are made of the finest quality felting wools, carefully selected and blended to ensure uniform quality and density.

| 1" Thick | 2" Thick |
|-----------|-----------|
| 4101-0011 | 4101-0013 |

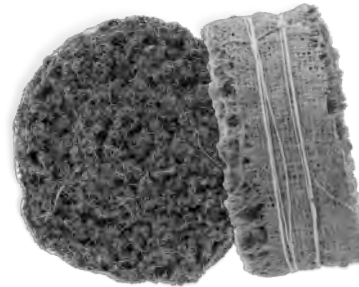

Cocoa Mat Buffers

For use with automatic top polishers. This buffer will apply just the right amount of pressure to bring out a consistent quality polish.

| | |
|-----|-----------|
| 10" | 4114-0042 |
|-----|-----------|

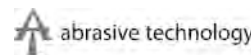

Buffer Cap



| | |
|----------|-----------|
| 5" Alum. | 4101-0015 |
|----------|-----------|



Pumice Bricks

Use to clean and refresh marble. Removes surface dirt and restores the original appearance quick and easy. 5-3/4" by 2-3/4".

| |
|-----------|
| 0709-0001 |
|-----------|

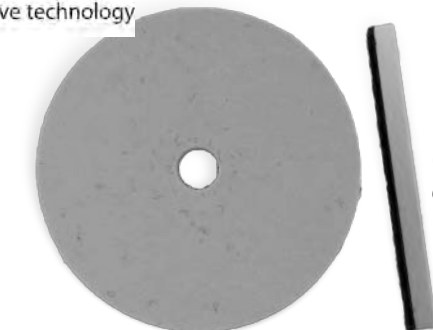

Q.R.S. connection

4" Felt Buffer

This high quality felt ensures positive results. Use to apply buffing compounds. Great for cleaning and restoring. Medium density for long life.

| | |
|----|-----------|
| 4" | 4101-0032 |
|----|-----------|

Felt Buffing Wheels

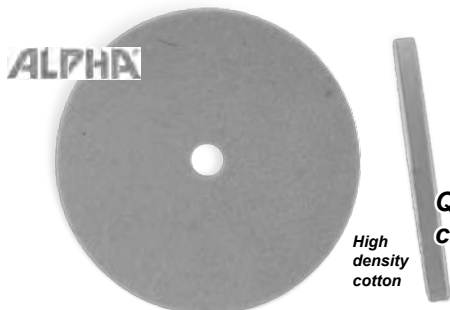

Q.R.S. connection

High density cotton

| | |
|----|-----------|
| 3" | 4101-0001 |
| 4" | 4101-0002 |
| 5" | 4101-0003 |

White Cotton Buffer

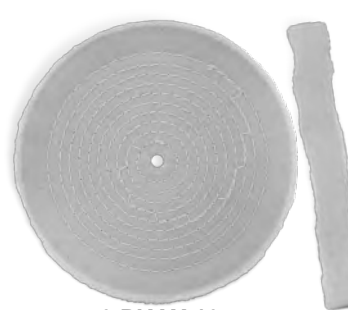

50 PLY X 10

Rows of sewing, 3/8" hole

| | |
|----|-----------|
| 7" | 4101-0024 |
|----|-----------|

Wool Bonnet



| | |
|----|-------------|
| 7" | 99-477-0119 |
|----|-------------|



Dia-Glo Diamond Buffing Compound
 abrasive technology

Formulated to achieve the best possible finish on stone surfaces. Easy to use, they quickly produce a mirror-like finish.

| Size | Powder Style | Item # |
|------|---------------------------|-----------|
| Qt. | M -Marble | 4111-0009 |
| Qt. | L -Light Granite | 4111-0006 |
| Qt. | D -Dark Granite | 4111-0008 |
| Pt. | S -Black Granite | 4111-0015 |
| | Spray Liquid Style | |
| Qt. | S -Black Granite | 4111-0017 |



AKEMI Liqui Polish

Can be used to remove marks and slight scratches on marble and granite. Reduces the time and steps to reach an extremely high polish in a very short amount of time. No acids & no solvents.

| Size | Liquid Style | Item # |
|-------|---------------|-----------|
| 1 lt. | Light Marble | 4102-0009 |
| 1 lt. | Dark Marble | 4102-0013 |
| 1 lt. | Light Granite | 4102-0007 |
| 1 lt. | Dark Granite | 4102-0010 |
| 1 lt. | Black Granite | 4102-0008 |

32 oz. Eureka Polishing Gel

Used to polish new and repolish old dulled heavy traffic granite. Can be used on smooth material, starting from 220 grit and above or as an alternative to tin oxide. Does not contain lead.



4102-0014

32 oz. Dr. Sal's Magic Stone Cream

Restores and Maintains a brilliant shine on marble and granite. The cream can polish floors and walls that have been honed to as little as 400 grit. 32 oz. will treat 300/550 Square Feet



| | |
|-------|-----------|
| Black | 4102-0016 |
| Clear | 4102-0017 |

BULK POLISHING POWERS CALL NOW! 800-328-7094

5X Extra Yellow Polishing Powder



Polishing compound to repolish marble for a better gloss or to polish out scratches.

Polishing Bars

Paste bars are melted into a buffer for high-gloss polishing of marble or granite. Simply apply to felt buffer wheel for polishing.



9.5"x2.5"x2.5"

| | |
|----------------|-----------|
| Marble (White) | 4104-0001 |
| Granite (Gray) | 4104-0002 |

GC-20 Polishing Compound



This inexpensive, specially blended polishing compound is well suited for polishing both marble and granite surfaces.

4111-0005

Pink Polishing Powder



For use on marble and glass.

4111-0021

Granite Polishing Powders



For use on dark granites.

4111-0020



For use on light granites.

4111-0019

Alum Oxide Polishing Powder



Formulated to give the user an inexpensive, high-gloss polish on marble or granite.

4111-0002

Cerium Oxide Marble Powder



Used in precision polishing & lapping applications. Perfect for putting the perfect polish on your marble.

0102-0002

Tin Oxide



No product used in the granite and marble industries is better known than Tin Oxide. Pure Tin Oxide is one of the best polishing agents for granite. It is fast in action, economical to use and produces a gem-brilliance. Packaged in 1, 5, 10, 25, 50 & 100 lb. containers. **Make a slurry and polish from wet to dry - adding more water as necessary.**

0112-0001

Polishing Powder Tints

| | |
|-------|-----------|
| Black | 4111-0003 |
| Red | 4111-0004 |

Oxalic Acid Powder



A good, low priced crystal cleaner for cleaning soiled, grimy granite. Also used as an aid in polishing marble.

0703-0002

Green Silicon Grinding Wheels

Very sharp cool cutting wheels. Excellent for sharpening carbide tipped bits as well as non-ferrous materials such as aluminum, glass, ceramic, and cast iron.

| Size | Face | Item # |
|------------------|------|-----------|
| 6" x 3/4" x 1" | C-80 | 1906-0064 |
| 6" x 1" x 1" | C-80 | 1906-0063 |
| 7" x 1" | C-80 | 1906-0040 |
| 8" x 1" x 1-1/4" | C-80 | 1906-0038 |

Alumium Oxide Grinding Wheels



Excellent general purpose wheel for routine use on bench grinders. Great for everyday shop use on various steels.

| Grit | Size | Item # |
|------|----------|-----------|
| 36 | 6" x 1" | 1906-0030 |
| 60 | 6" x 1" | 1906-0101 |
| 80 | 10" x 1" | 1906-0102 |

Silicon Carbide Grinding Wheels



| 4 x 2" | | 5 x 2" | |
|--------|-----------|--------|-----------|
| Grit | Item # | Grit | Item # |
| #24 | 1903-0124 | #24 | 1903-0134 |
| #36 | 1903-0125 | #36 | 1903-0135 |
| #46 | 1903-0126 | #46 | 1903-0136 |
| #60 | 1903-0127 | #60 | 1903-0137 |
| #80 | 1903-0128 | #80 | 1903-0138 |
| #120 | 1903-0129 | #120 | 1903-0139 |
| #220 | 1903-0130 | #220 | 1903-0140 |

Spirakut Discs



Size: 7" x 7/8"

| Grit | Item # |
|------|-----------|
| #16 | 1905-0005 |
| #24 | 1905-0016 |
| #36 | 1905-0018 |
| #50 | 1905-0019 |
| #100 | 1905-0017 |
| #120 | 1905-0011 |

These discs have been the standard for grinding on marble, granite and stone in Italy and Europe for almost 30 years. Use for wet or dry grinding. The dome shape allows the operator to apply 300% more abrasive to the work surface which insures faster cutting and less operator fatigue.

Spiralcool Backer Pads



Made of heavy molded rubber. Used with 5/8"-11 threaded lock-nut to secure the Spirakut, or Rival sanding discs.

| Type/Size | Item # |
|---------------|-----------|
| 7" | 4113-0029 |
| 5/8" lock-nut | 4113-0007 |
| Wrench | 4113-0004 |

Grinding Wheel Dresser

Dressing cleans away foreign particles and exposes sharp new cutting edges.



Weight: 2 lbs.

| Size | Item # |
|-----------------|-------------|
| Handle w/Blades | 99-016-0001 |
| 4-Blades | 99-016-0002 |

8" x 1 1/2" x 1 1/2" Silicon Carbide Rubbing Stones

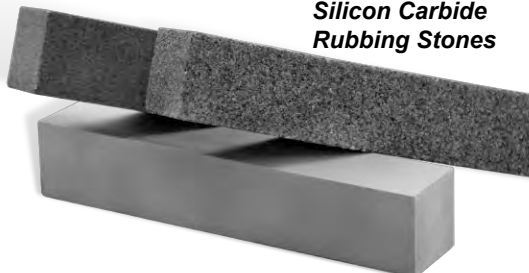

These abrasive rubbing bricks are most commonly used for hand polishing and minor repairs on granite and marble surfaces. Also used for dressing diamond blades.

| Grit | Item # |
|------|-----------|
| #24 | 4112-0010 |
| #36 | 4112-0011 |
| #60 | 4112-0012 |
| #80 | 4112-0013 |
| #120 | 4112-0014 |
| #220 | 4112-0015 |
| #320 | 4112-0016 |
| #600 | 4112-0017 |

Silicon Carbide Sanding Belts



Industrial grade belts work great for granite and other stone. Sold individually or in boxes of 10.

| Grit | 3" x 21" | 3" x 24" |
|------|-----------|-----------|
| #24 | 1901-0069 | 1901-0050 |
| #36 | 1901-0024 | 1901-0049 |
| #40 | 1901-0070 | 1901-0051 |
| #60 | 1901-0037 | 1901-0033 |
| #80 | 1901-0022 | 1901-0034 |
| #120 | 1901-0021 | 1901-0035 |
| #220 | 1901-0026 | 1901-0036 |
| #320 | 1901-0027 | 1901-0059 |
| #400 | 1901-0028 | 1901-0060 |
| #600 | 1901-0029 | 1901-0061 |

RIVAL Hook & Loop Grinding Discs



High quality industrial grade wet/dry silicon carbide sanding discs. With hook and loop backing.

C-Weight Wet/Dry

| Grit | BOX | 4" | 5" |
|-------|-----|-----------|-----------|
| #60 | 50 | 1905-0090 | 1905-0082 |
| #80 | 50 | 1905-0091 | 1905-0083 |
| #120 | 50 | 1905-0092 | 1905-0084 |
| #220 | 50 | 1905-0093 | 1905-0085 |
| #320 | 50 | 1905-0095 | 1905-0087 |
| #400 | 50 | 1905-0096 | 1905-0088 |
| #600 | 50 | 1905-0097 | 1905-0089 |
| #1200 | 50 | 1905-0112 | 1905-0113 |

Dry NO HOLE - E-Weight Heavy Duty

| Grit | BOX | 4" | 5" |
|------|-----|-----------|-----------|
| #40 | 50 | 1908-0149 | 1908-0304 |
| #60 | 50 | 1908-0150 | 1908-0305 |
| #80 | 50 | 1908-0151 | 1908-0306 |
| #120 | 50 | 1908-0152 | 1908-0307 |
| #220 | 50 | 1908-0153 | 1908-0308 |
| #320 | 50 | 1908-0154 | 1908-0309 |
| #400 | 50 | 1908-0155 | 1908-0310 |
| #600 | 50 | 1908-0156 | 1908-0311 |

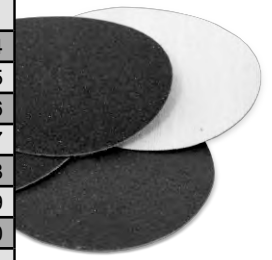

RIVAL 5" PSA Silicon Sanding Discs



Peel and stick for all your sanding and polishing needs. PSA backer pad.

Dry - E-Weight Heavy Duty

| Grit | BOX | 5" |
|------|-----|-----------|
| #40 | 100 | 1908-0141 |
| #60 | 100 | 1908-0142 |
| #80 | 100 | 1908-0143 |
| #120 | 100 | 1908-0144 |

C-Weight Wet/Dry

| Grit | BOX | 5" |
|-------|-----|-----------|
| #220 | 100 | 1908-0104 |
| #320 | 100 | 1908-0106 |
| #400 | 100 | 1908-0107 |
| #600 | 100 | 1908-0108 |
| #1200 | 100 | 1908-0312 |

RIVAL 7" Cloth Backed Wet/Dry Silicon Carbide Discs

Wet/Dry

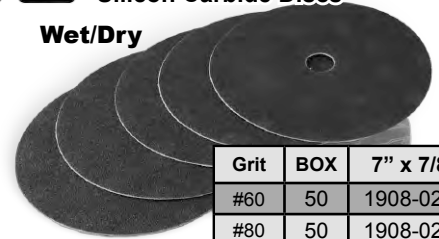

High quality wet silicon carbide sanding discs. **Cloth**

| Grit | BOX | 7" x 7/8" |
|------|-----|-----------|
| #60 | 50 | 1908-0213 |
| #80 | 50 | 1908-0214 |
| #120 | 50 | 1908-0215 |
| #220 | 50 | 1908-0216 |
| #320 | 50 | 1908-0217 |

RIVAL 7" Heavy-Duty Plain Paper Dry Silicon Carbide Discs

Plain Paper Dry Silicon Carbide Discs



High quality industrial grade dry silicon carbide sanding discs. **Plain Paper E-Weight**

| Grit | BOX | 7" x 7/8" |
|------|-----|-----------|
| #36 | 50 | 1908-0077 |
| #40 | 50 | 1908-0069 |
| #60 | 50 | 1908-0079 |
| #80 | 100 | 1908-0085 |
| #120 | 100 | 1908-0071 |
| #220 | 100 | 1908-0072 |
| #320 | 100 | 1908-0073 |
| #400 | 100 | 1908-0087 |
| #600 | 100 | 1908-0078 |

RIVAL 7" Hook & Loop Dry Silicon Carbide Discs



High quality dry silicon carbide sanding discs. **Q.R.S E-Weight**

| Grit | BOX | 7" |
|------|-----|-----------|
| #24 | 25 | 1905-0107 |
| #36 | 25 | 1905-0115 |
| #40 | 25 | 1905-0114 |
| #60 | 50 | 1905-0116 |
| #80 | 50 | 1905-0117 |
| #120 | 50 | 1905-0118 |
| #220 | 50 | 1905-0119 |
| #320 | 50 | 1905-0120 |
| #400 | 50 | 1905-0121 |
| #600 | 50 | 1905-0122 |

ALPHA Hook & Loop Silicon Carbide Wet/Dry Discs



Consists of waterproof hook & loop combined with silicon carbide abrasive, which works well to polish: marble, granite, travertine, terrazzo, and onyx. Sold in boxes of 50 pieces per grit or an assortment box of 50 pieces. Hook & loop backed. Use with hook & loop backer pads.

| Grit | BOX | 4" | 5" |
|----------|-----|-----------|-----------|
| #80 | 50 | 1908-0031 | 1908-0039 |
| #120 | 50 | 1908-0032 | 1908-0040 |
| #240 | 50 | 1908-0033 | 1908-0041 |
| #320 | 50 | 1908-0034 | 1908-0042 |
| #400 | 50 | 1908-0035 | 1908-0043 |
| #500 | 50 | 1908-0036 | 1908-0044 |
| #600 | 50 | 1908-0037 | 1908-0045 |
| Assorted | 50 | 1908-0038 | 1908-0046 |

RIVAL Grinding Wheels - Aluminum

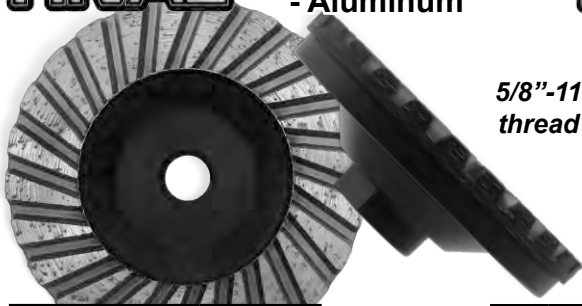

5/8"-11 thread

| Size | Grit | Item # |
|------|--------------|-----------|
| 4" | Fine | 1903-0117 |
| 4" | Medium | 1903-0116 |
| 4" | Coarse | 1903-0114 |
| 4" | Extra Coarse | 1903-0115 |

Premium diamond cup wheels with lightweight aluminum backer.

RIVAL 2" Grinding Wheels - Aluminum



| Size | Grit | Item # |
|------|--------|-----------|
| 2" | Coarse | 1903-0315 |

RIVAL Turbo T-Cup Diamond Wheels



Aggressive Style! Super lightweight design and fast grinding.

| Size | Grit | Item # |
|------|--------|-----------|
| 4" | Coarse | 1903-0093 |
| 5" | Coarse | 1903-0094 |
| 7" | Coarse | 1903-0096 |

CYCLONE BY DIAMAX Grinding Wheels

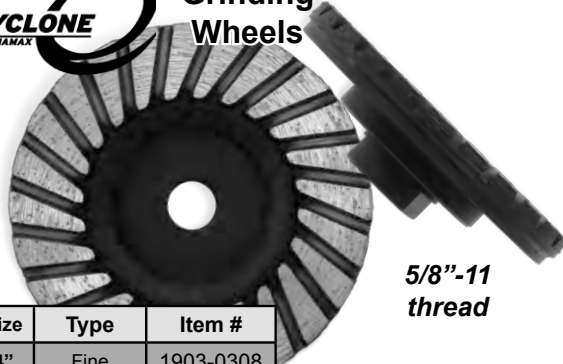

5/8"-11 thread

| Size | Type | Item # |
|------|--------|-----------|
| 4" | Fine | 1903-0308 |
| 4" | Medium | 1903-0307 |
| 4" | Coarse | 1903-0306 |
| 5" | Coarse | 1903-0309 |
| 6" | Coarse | 1903-0310 |
| 7" | Coarse | 1903-0311 |

Balanced to eliminate vibration and chipping when shaping. Aggressive design with thick turbo segments and diamonds.

RIVAL Turbo Double Layer Cup Wheels



5/8"-11 thread

| Size | Grit | Item # |
|------|--------|-----------|
| 4" | Coarse | 1903-0323 |
| 4" | Medium | 1903-0324 |
| 4" | Fine | 1903-0325 |

Double layer for extended life and durability!

RIVAL Flat Resin Shaping Wheels

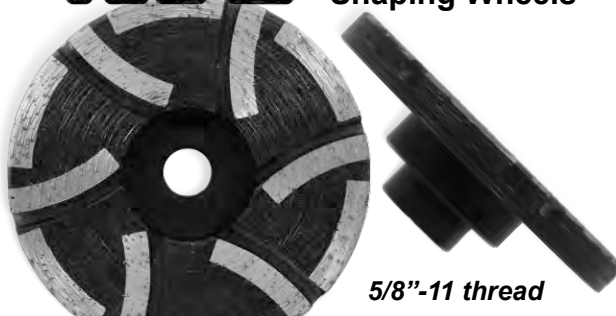

5/8"-11 thread

| Size | Type | Item # |
|------|--------------|-----------|
| 4" | Fine | 1903-0347 |
| 4" | Medium | 1903-0346 |
| 4" | Coarse | 1903-0345 |
| 4" | Extra Coarse | 1903-0344 |

Flat resin cup wheel with 12 diamond filled segments.

Balanced for smooth precision grinding.

RIVAL Vacuum Brazed Diamond Grinding Wheels



5/8"-11 Thread

| Size | Grit | Item # |
|------|--------|-----------|
| 4" | Coarse | 1921-0004 |
| 4" | Medium | 1921-0005 |
| 5" | Coarse | 1921-0006 |
| 5" | Medium | 1921-0007 |

- For use on angle grinders
- Very cost effective
- One of the fastest way to cut and grind stone!

ALPHA Ceramica Resin Polishing Pads

A proven top performer for a professional high quality polish.

- Step 1:
Vitrified discs
(60, 150,300 grits)
- Step 2:
Resin discs
(150, 300, 500, 100, 2000 & 3000 grits).
- Step 3:
Final polisher discs (Black for granite, White for marble).



| Grit | 3" | 4" | 5" |
|-------|-----------|-----------|-----------|
| 150 | 4106-0026 | 4106-0038 | 4106-0053 |
| 300 | 4106-0027 | 4106-0039 | 4106-0054 |
| 500 | 4106-0028 | 4106-0040 | 4106-0055 |
| 1000 | 4106-0029 | 4106-0041 | 4106-0056 |
| 2000 | 4106-0030 | 4106-0042 | 4106-0057 |
| 3000 | 4106-0031 | 4106-0043 | 4106-0058 |
| Black | 4106-0046 | 4106-0061 | 4106-0080 |
| White | 4106-0047 | 4106-0062 | 4106-0081 |

- Use Under 4,000 RPM
- Q.R.S. connection
- Use wet only

DX Series DX-PRO Polishing Pads

- One of the strongest Q.R.S connections available
- For granite, marble, engineered stone, & concrete
- 3mm thick
- Premium quality
- Extra flexible
- Use Wet Only

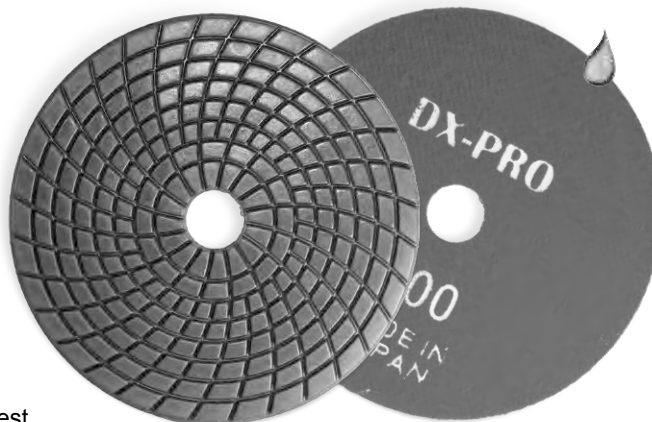

| Grit | 4" | 5" |
|-------|-----------|-----------|
| 40 | 4106-1440 | 4106-1449 |
| 60 | 4106-1429 | - |
| 100 | 4106-1441 | 4106-1450 |
| 200 | 4106-1442 | 4106-1451 |
| 400 | 4106-1443 | 4106-1452 |
| 800 | 4106-1444 | 4106-1453 |
| 1500 | 4106-1445 | 4106-1454 |
| 3000 | 4106-1446 | 4106-1455 |
| Black | 4106-1447 | 4106-1456 |
| White | 4106-1448 | 4106-1457 |

Designed to compete and beat the finest polishing pads from competing brands in both price and performance. Has one of the strongest Q.R.S. backing in the industry to insure your pad will stay on the holder, even after hundreds of uses. Try these pads and throw your old one out the door. Save money and get better results. Use on granite, marble, and engineered stone.

RIVAL Premium Polishing Pads

Whatever you're looking for, this pad delivers!

Texture allows for no break-in period!

- 3mm thick
- Use Wet Only
- Use Under 5,000 RPM

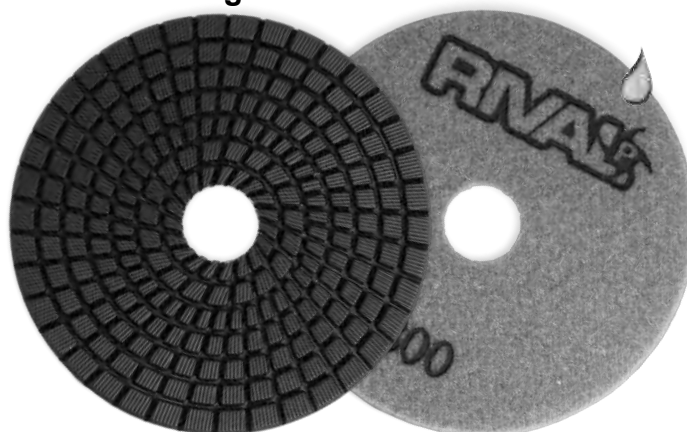

| Grit | 3" | 4" |
|-------|-----------|-----------|
| 50 | 4106-1615 | 4106-1578 |
| 100 | 4106-1616 | 4106-1579 |
| 200 | 4106-1617 | 4106-1580 |
| 400 | 4106-1618 | 4106-1581 |
| 800 | 4106-1619 | 4106-1582 |
| 1500 | 4106-1620 | 4106-1583 |
| 3000 | 4106-1621 | 4106-1584 |
| Black | 4106-1622 | 4106-1586 |
| White | 4106-1623 | 4106-1585 |

Con-Dri Polishing Pads

- *Best dry pad available*
- *Superior Polish*
- *Extra Flexible*
- *Q.R.S Connection*
- *Use Under 4,000 RPM*

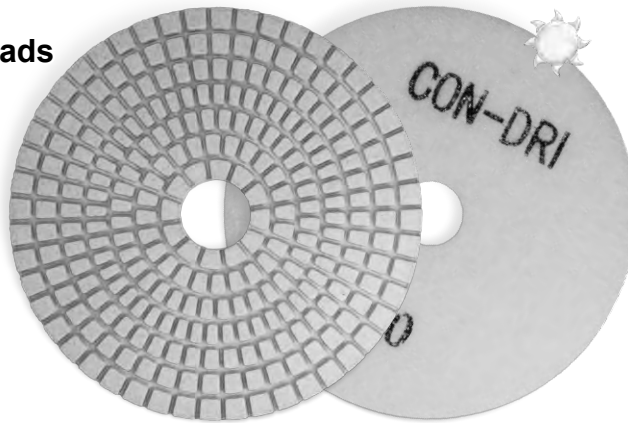

| Grit | 4" | 5" |
|------|-----------|-----------|
| 50 | 4106-1488 | 4106-1496 |
| 100 | 4106-1489 | 4106-1497 |
| 200 | 4106-1490 | 4106-1498 |
| 400 | 4106-1491 | 4106-1499 |
| 800 | 4106-1492 | 4106-1500 |
| 1500 | 4106-1493 | 4106-1501 |
| 3000 | 4106-1494 | 4106-1502 |

DX PRO DRY Polishing Pads

Extreme High Speed professional dry pads. Can be used on granite, and marble. Provides excellent polish on engineered stone when used wet. *Can be used wet or dry.*

- *Extremely flexible*
- *Q.R.S Connection*
- *Use Under 4,000 RPM*

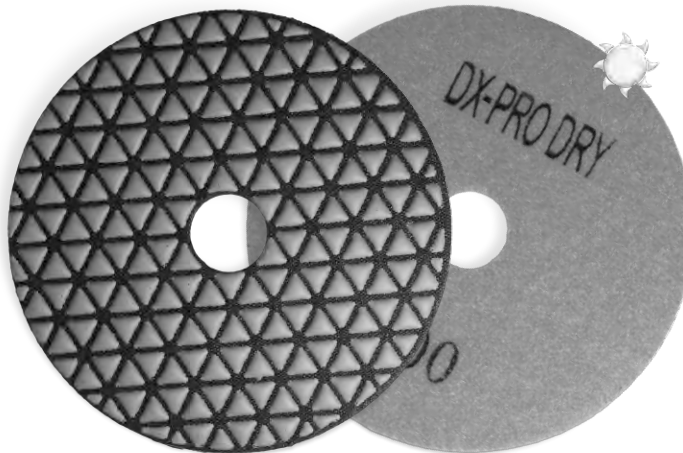

| Grit | 4" |
|------|-----------|
| 60 | 4106-1507 |
| 100 | 4106-1508 |
| 200 | 4106-1509 |
| 400 | 4106-1510 |
| 800 | 4106-1511 |
| 1500 | 4106-1512 |
| 3000 | 4106-1513 |
| 4000 | 4106-1514 |
| 5000 | 4106-1515 |

3M Polishing Pads

- *Very flexible*
- *Extra long life*
- *Q.R.S backing*
- *For marble & concrete polishing*
- *One of the highest quality pads available*

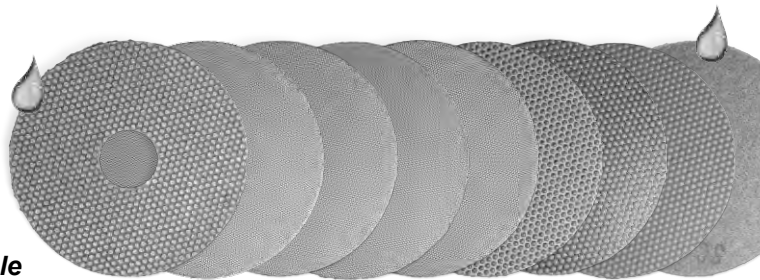

| Grit | 4" | 5" |
|------|-----------|-----------|
| 60 | 4106-1050 | 4106-0825 |
| 120 | 4106-1051 | 4106-0826 |
| 220 | 4106-1052 | 4106-0827 |
| 400 | 4106-1053 | 4106-0828 |
| 600 | 4106-1054 | 4106-0877 |
| 800 | 4106-1055 | 4106-0824 |
| 1800 | 4106-1056 | 4106-0823 |
| 3000 | 4106-1057 | 4106-0822 |

Micron graded diamond abrasive, in Q.R.S. disc form. For finishing non-ferrous metals, stone, glass, and ceramics.



Copper Flexible Polishing Pads

Specially designed copper bond for long lasting and high performance. Designed for granite, marble, natural and engineered stone, and can even be used on concrete.

- **Q.R.S Connection**
- **Use wet only**
- **Use Under 4,000 RPM**

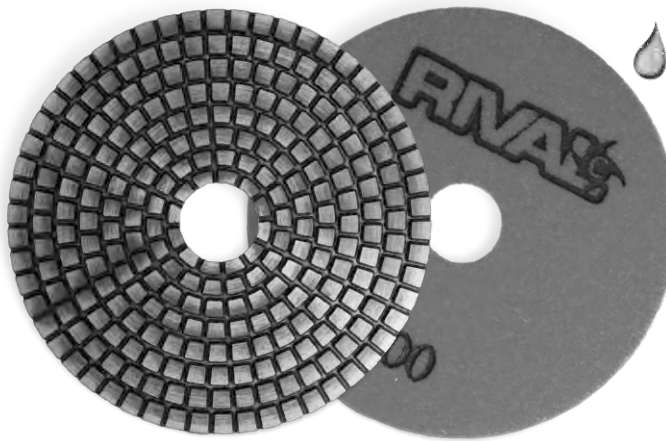

| Grit | 4" | 5" |
|------|-----------|-----------|
| 30 | 4106-1587 | 4106-0757 |
| 50 | 4106-1588 | 4106-0758 |
| 100 | 4106-1748 | 4106-0759 |



Copper Resin Pads

Designed with a copper bond for long lasting. Copper dissipates heat while the resin is given longer life. Designed for granite, marble, natural and engineered stone.

- **Q.R.S Connection**
- **Use wet only**
- **Use Under 4,000 RPM**

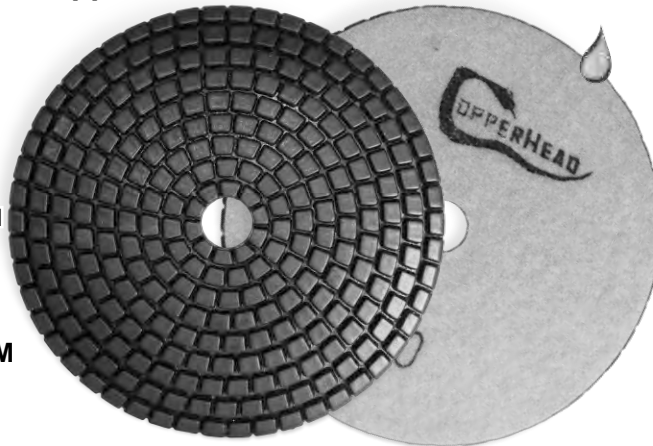

| Grit | 3" | 4" | 5" |
|------|-----------|-----------|-----------|
| 35 | - | 4106-1577 | 4106-1713 |
| 50 | 4106-2061 | 4106-1533 | 4106-1714 |
| 100 | 4106-2062 | 4106-1534 | 4106-1715 |
| 200 | 4106-2063 | 4106-1535 | 4106-1716 |
| 400 | 4106-2064 | 4106-1536 | 4106-1717 |
| 800 | 4106-2065 | 4106-1537 | 4106-1718 |
| 1500 | 4106-2066 | 4106-1538 | 4106-1719 |
| 3000 | 4106-2067 | 4106-1539 | 4106-1720 |
| 5000 | 4106-2068 | 4106-1540 | 4106-1721 |



Convex Polishing Pads

These pads are useful for ogee edges. Good for polishing difficult to reach areas like inside corners of sink cut outs. Use on granite, marble and engineered stone.
Size: 76mm

- **Q.R.S Connection**
- **Use wet only**
- **Use Under 5,000 RPM**

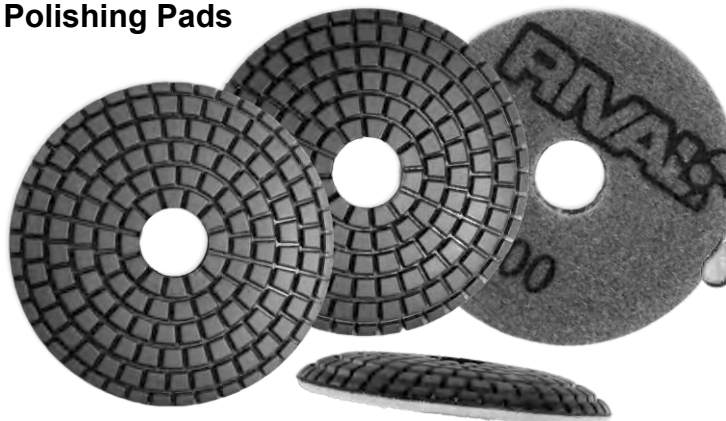

| Grit | 3" |
|-------|-----------|
| 50 | 4106-1592 |
| 100 | 4106-1593 |
| 200 | 4106-1594 |
| 400 | 4106-1595 |
| 800 | 4106-1596 |
| 1500 | 4106-1597 |
| 3000 | 4106-1598 |
| Black | 4106-1599 |
| White | 4106-1600 |

Cyclone 4" Diamond Vitrified Polishing Pads

Vitrified pads are a very aggressive long lasting pre-polish disc. Designed to remove saw and grinding marks to prep stone for polishing.

- Q.R.S Connection
- Use wet only

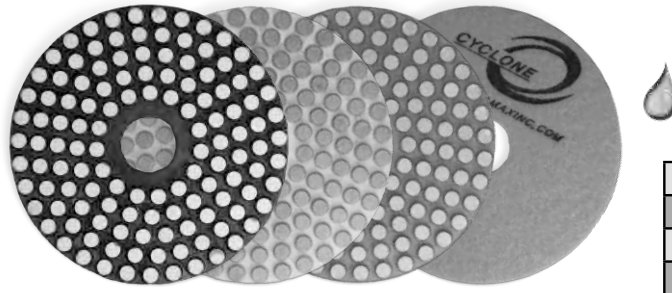

| Grit | 4" |
|------|-----------|
| 50 | 4106-1589 |
| 150 | 4106-1590 |
| 300 | 4106-1591 |



Ceramica Vitrified Polishing Pads

These discs are specifically designed to handle the hard job of removing saw and grinding marks in order to prepare the stone for polishing. The vitrified bond is compressed diamond impregnated pellet surrounded by plastic. Alpha® Vitrified Ceramica Pads are aggressive and long lasting.

- Q.R.S Connection
- Use wet only
- Use Under 4,000 RPM

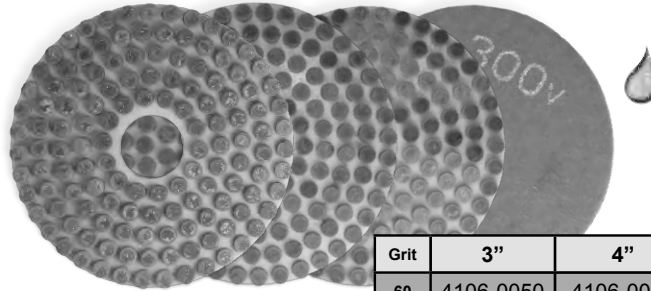

| Grit | 3" | 4" | 5" |
|------|-----------|-----------|-----------|
| 60 | 4106-0050 | 4106-0082 | 4106-0086 |
| 150 | 4106-0044 | 4106-0059 | 4106-0084 |
| 300 | 4106-0045 | 4106-0060 | 4106-0085 |



TurboShine Polishing Discs

Flexible

Rigid



| Grit | 3" Flexible | 3" Rigid |
|---------|-------------|-----------|
| 100 | 4106-2089 | 4106-2082 |
| 200 | 4106-2090 | 4106-2083 |
| 500 | 4106-2091 | 4106-2084 |
| 1000 | 4106-2092 | 4106-2085 |
| 2000 | 4106-2093 | 4106-2086 |
| 3000 | 4106-2094 | 4106-2087 |
| Black B | 4106-2095 | 4106-2088 |

Polishing and Scratch Removal System for Natural & Engineered Stone Countertops.

- Use wet only
- Use Under 4,000 RPM

| | | |
|------------------|------------------|-------------------------------------|
| 2000 ES Flexible | 4106-2096 | Engineered Stone/ Quartz Surface |
|------------------|------------------|-------------------------------------|

ALPHA
TurboShine Adapter
4113-0160

Diamond Hand Pads

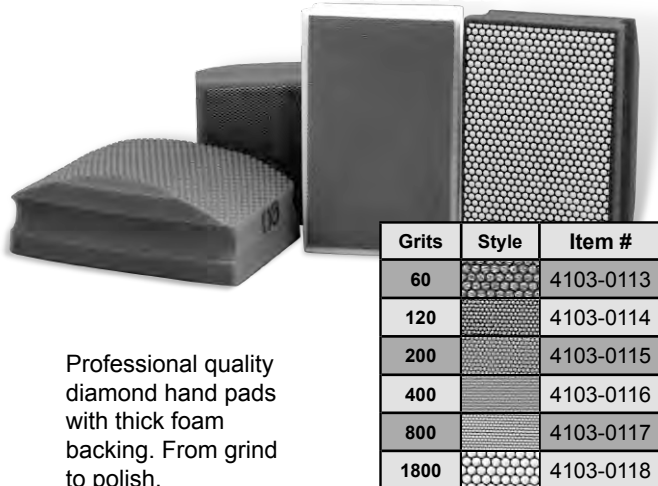

Professional quality diamond hand pads with thick foam backing. From grind to polish.

| Grits | Style | Item # |
|-------|-------|-----------|
| 60 | | 4103-0113 |
| 120 | | 4103-0114 |
| 200 | | 4103-0115 |
| 400 | | 4103-0116 |
| 800 | | 4103-0117 |
| 1800 | | 4103-0118 |

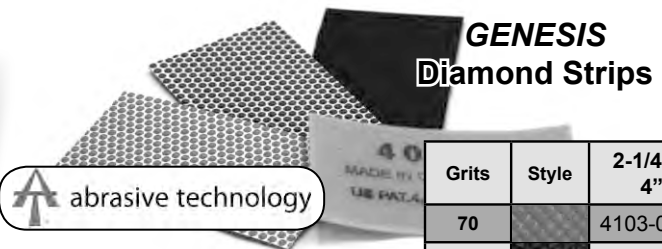

Q.R.S. connection

Diamond strips are flexible to allow for shaping and smoothing small, intricate areas.

GENESIS Diamond Strips

| Grits | Style | 2-1/4" x 4" |
|-------------------------|-------|-------------|
| 70 | | 4103-0020 |
| 120 | | 4103-0017 |
| 220 | | 4103-0013 |
| 400 | | 4103-0010 |
| 600R | | 4103-0005 |
| 800 | | 4103-0006 |
| 1800 | | 4103-0007 |
| 3500 | | 4103-0008 |
| Handblock | | 4103-0011 |
| Set: 8 Grits, Handblock | | 4103-0032 |



Hook & Loop Backer Heads

| | |
|-----------|-----------|
| 2" Rubber | 4113-0083 |
| 3" Rubber | 4113-0088 |
| 4" Rubber | 4113-0085 |
| 5" Rubber | 4113-0122 |

5/8"-11 thread

Q.R.S. connection



| | |
|--------------------|-----------|
| 4" Rigid Composite | 4113-0161 |
|--------------------|-----------|

Q.R.S. connection



Backer Heads



Q.R.S. connection

| | |
|-----------|-----------|
| 3" Rubber | 4113-0181 |
| 4" Rubber | 4113-0184 |
| 5" Rubber | 4113-0183 |



Hook & Loop Backer Heads with 5/8"-11 female threads



| | |
|----------|-----------|
| 3" Rigid | 4113-0013 |
| 4" Rigid | 4113-0014 |
| 5" Rigid | 4113-0026 |

Max RPM
6,000 RPM

Q.R.S. connection



| | |
|-----------|-----------|
| 2" Rubber | 4113-0022 |
| 3" Rubber | 4113-0023 |
| 4" Rubber | 4113-0024 |
| 5" Rubber | 4113-0030 |

Highly resistant to the rigors of daily use!

GREEN Flexible Backer Head

Q.R.S. connection



5/8"-11 thread

| | |
|-----------|-----------|
| 4" Rubber | 4113-0135 |
|-----------|-----------|

EXTREME Flexible Backer Head



Q.R.S. connection



5/8"-11 thread

| | |
|-----------|-----------|
| 4" Rubber | 4113-0147 |
|-----------|-----------|

Aluminum Backer Heads with brass hub insert

5/8"-11 thread



Q.R.S. connection

| | | |
|--------|-------|-----------|
| 3" | Rigid | 4113-0074 |
| 4" | Rigid | 4113-0058 |
| 5" | Rigid | 4113-0075 |
| 6-5/8" | Rigid | 4113-0114 |

Diskit Backer Pads

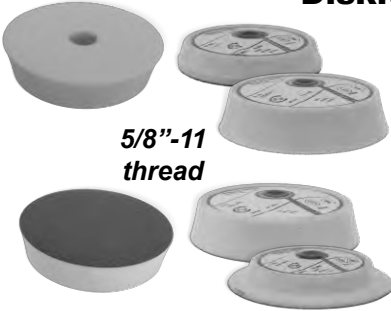

5/8"-11 thread

| | | |
|----|-----|-----------|
| 4" | QRS | 1908-0086 |
| 5" | QRS | 1908-0088 |

Backer pad to work with PSA and QRS backed sanding discs. 10,000 RPM Max.

| | | |
|----|-----|-----------|
| 5" | PSA | 1908-0064 |
| 5" | PSA | 1908-0066 |

Ogee Aluminum Rubber Backer Heads

Makes it able to polish concave profiles! Rubber helps protect edges.



5/8"-11 thread

Polish inside F, FGS, FG, FV, FZ, and more!

| | |
|-------|-----------|
| 3.25" | 4113-0134 |
|-------|-----------|

Thick Backer Heads

5/8"-11 thread

Q.R.S. connection

Extremely flexible backer heads.

1" Thick



| | |
|----|-----------|
| 4" | 4113-0159 |
|----|-----------|

Foam Hook & Loop Backer Heads

5/8"-11 thread

1/2" Thick

Q.R.S. connection



| | |
|----|-----------|
| 3" | 4113-0009 |
| 4" | 4113-0015 |
| 5" | 4113-0016 |
| 7" | 4113-0032 |

RIVAL

Polishing Drum Wheels



| Grit | 2" x 2" |
|-------|-----------|
| 50 | 1919-0163 |
| 100 | 1919-0164 |
| 200 | 1919-0165 |
| 400 | 1919-0166 |
| 800 | 1919-0167 |
| 1500 | 1919-0168 |
| 3000 | 1919-0169 |
| Black | 1919-0170 |
| White | 1919-0171 |

Use wet or dry!

- 5/8"-11 female thread
- with center water

Edge polishing for inside radius.
Recommended use: oscillate up and down for proper drum wear.

RIVAL

Zero Tolerance Wheels

with center water



The fastest way to remove material after cutting out holes with a diamond blade, or to shape a radius on the outside edge.

5/8"-11 female thread

| Size | Item # |
|-------------|-----------|
| 1" x 1-3/8" | 1919-0209 |
| 2" x 1-3/8" | 1919-0100 |
| 3" x 1-3/8" | 1919-0101 |
| 4" x 1-3/8" | 1919-0102 |

RIVAL

Resin Filled Zero Tolerance Wheels

with center water



Resin diamond fills in the area between the metal bond diamond. The result is fast stock removal for radius work that is chip-free!!

5/8"-11 female thread

| Size | Coarse |
|-------------|-----------|
| 1" x 1-5/8" | 1919-0210 |
| 2" x 1-5/8" | 1919-0142 |
| 3" x 1-5/8" | 1919-0143 |
| 4" x 1-5/8" | 1919-0141 |

RIVAL

Brazed Diamond Drum Clean-Up Wheels

with center water



With top bearing and 5/8"-11 thread.

Best used with a template.

| Size | Grit | Item # |
|--------|------|-----------|
| 2 x 2" | #30 | 1919-0172 |
| 2 x 2" | #100 | 1919-0173 |
| 3 x 2" | #30 | 1919-0174 |
| 3 x 2" | #100 | 1919-0175 |



DIAMONDWRIGHT

Electroplated Drum Wheels with bearings

Made in U.S.A. 

| Type | Diamonds | Size | Bearing | C/Water | Item # |
|---------|----------|------------|---------|---------|-----------|
| 5/8"-11 | 30/40 | 2" Ø x 2" | Top | Yes | 4313-0124 |
| 5/8"-11 | 50/60 | 2" Ø x 2" | Top | Yes | 4313-0181 |
| 5/8"-11 | 30/40 | 3" Ø x 2" | Top | Yes | 4313-0127 |
| 5/8"-11 | 50/60 | 3" Ø x 2" | Top | Yes | 4313-0154 |
| Ghines | 30/40 | 1½" Ø x 2" | Bottom | No | 4313-0129 |
| Ghines | 50/60 | 1½" Ø x 2" | Bottom | No | 4313-0169 |
| Ghines | 30/40 | 2" Ø x 2" | T or B | No | 1919-0099 |





Contour Cat - KS-8013



Comes with FREE heavy duty carrying case

This German built industrial 2 hp, variable speed router is the most versatile machine ever built for countertop work. Perfect for edging countertops up to 4cm using **Diamond Router Bits**. Also is small enough to cleanup, edge and polish inside sink holes! No other machine on the market can do all this. Has height adjustment plate, splash guard, and a central and external waterfeed. Felt plate rides on a layer of water to help prevent surface scratching. The motor is very powerful and will last for years.

6 Month Limited Warranty

Check out our Router Bits
Page 34-35 →

Variable Speed

| | |
|------------------|-----------|
| Carbon Brush SET | 4306-0080 |
| | 4308-0044 |

Apex Adapter for Router Bits
4308-0087

- 5/8"-11 threaded arbor**
- Voltage: 120V - 56/60 Hz
- Power Input: 1,300W, 1,500W
- Weight: 14.3 lbs.

- Max. Tool Diameter: 5" (120mm)
- Variable Speed: 2,400 to 6,800 RPM
- Horse power: 1.8 hp, 2.0 hp, 12.5 Amp

RIVAL Oscillating Drum Wheel System

Oscillating Head



5/8"-11 female thread
4108-0024

Use wet or dry!



To polish an inside radius quickly.

| Type | Grit | Item # |
|------------|-------|-----------|
| Resin | #50 | 1920-0040 |
| Resin | #100 | 1920-0041 |
| Resin | #200 | 1920-0042 |
| Resin | #400 | 1920-0043 |
| Resin | #800 | 1920-0044 |
| Resin | #1500 | 1920-0045 |
| Resin | #3000 | 1920-0046 |
| Final Buff | Buff | 1920-0047 |



Oscillating Head Drum Wheel System

Diamond grinding and polishing cylinders for professional edge processing wet application in connection with the GALESKI edge processing system Contour Cat 80. The drums use resin based with the oscillating head "RS" resulting in scratch-free and exact angular polishing of edges.



Galeski Oscillating Head



5/8"-11 female thread

4108-0005

| Type | Grit | Item # |
|------------|-------|-----------|
| Resin | #200 | 1920-0021 |
| Resin | #400 | 1920-0022 |
| Resin | #800 | 1920-0023 |
| Resin | #1500 | 1920-0024 |
| Resin | #3000 | 1920-0025 |
| Final Buff | Buff | 1920-0026 |

DIAMONDWRIGHT™ Drum Wheels
without center water and no bearings

Made in U.S.A. 

No load up design.



| Type | Diamonds | Size | C/Water | Item # |
|---------|----------|-------------------|---------|-----------|
| 5/8"-11 | 30/40 | 1" Ø x 2 3/4" | Yes | 4309-0179 |
| 5/8"-11 | 50/60 | 1" Ø x 2 3/4" | Yes | 4309-0180 |
| 5/8"-11 | 30/40 | 1 1/2" Ø x 1 1/2" | No | 1919-0107 |
| 5/8"-11 | 30/40 | 2" Ø x 2" | No | 1919-0109 |
| 5/8"-11 | 30/40 | 3" Ø x 1 1/2" | No | 1919-0112 |

Coarse Segmented Drums
with 5/8" threaded connection

DIAMONDWRIGHT™

Made in U.S.A. 

For fast stock removal.



| Description | Item # |
|--|-----------|
| 3" dia. x 1 1/2" Wide Lightweight Drum w/ center water | 1919-0122 |

**more hogger styles available by special order.*

Plated Wheels with Ghines Connection
with Bearing

DIAMONDWRIGHT™

Other POS 2
AVAILABLE BY
SPECIAL ORDER

Longer life than brazed wheels!

| Form | Size | Diamonds | Profile | Bearing | Item # |
|------|------|----------|---------------|---------|-----------|
| B | 1/4" | 30/40 | Half Bullnose | Bottom | 4309-0043 |
| B | 3/8" | 30/40 | Half Bullnose | Bottom | 4309-0044 |
| B | 3/8" | 50/60 | Half Bullnose | Bottom | 4309-0066 |
| V | 2 cm | 30/40 | Full Bullnose | Middle | 4310-0114 |
| V | 3 cm | 30/40 | Full Bullnose | Middle | 4310-0116 |
| F | 2 cm | 30/40 | Ogee | Bottom | 4304-0092 |
| F | 3 cm | 30/40 | Ogee | Bottom | 4304-0093 |
| E | 1/4" | 30/40 | Bevel | Bottom | 4312-0012 |
| E | 1/2" | 30/40 | Bevel | Bottom | 4312-0013 |
| Z | 2" | 30/40 | --- | T or B | 1919-0099 |



Made in U.S.A. 

Re-Tip and Re-Electroplate most Tools in 3-10 days.

Profile Wheels with 5/8-11 threaded connection
with Bearing & Center Waterfeed

DIAMONDWRIGHT™

Other POS 2
AVAILABLE BY
SPECIAL ORDER

| Form | Size | Diamonds | Profile | Bearing | Item # |
|------|-------|----------|---------------|---------|-----------|
| B | 3/16" | 30/40 | Half Bullnose | Bottom | 4309-0036 |
| B | 5/8" | 30/40 | Half Bullnose | Bottom | 4309-0040 |
| B | 5/8" | 50/60 | Half Bullnose | Bottom | 4309-0078 |
| B | 3 cm | 30/40 | Half Bullnose | Bottom | 4309-0061 |
| B | 3 cm | 50/60 | Half Bullnose | Bottom | 4309-0081 |
| V | 3 cm | 30/40 | Full Bullnose | Middle | 4310-0110 |
| F | 3 cm | 30/40 | Ogee | Bottom | 4304-0096 |



Made in U.S.A. 

Re-Tip and Re-Electroplate most Tools in 3-10 days.

1/2" Shaft Router Tools



| Form | Size | Diamonds | Profile | Bearing | Item # |
|------|-------|----------|---------------|---------|-----------|
| B | 3/16" | 30/40 | Half Bullnose | Bottom | 4309-0048 |
| B | 3/8" | 30/40 | Half Bullnose | Bottom | 4309-0050 |
| E | 3/4" | 30/40 | Bevel | Bottom | 4312-0015 |

1/2" Shaft Straight Router Tools



| Form | Size | Diamonds | Item # |
|------|---|----------|-----------|
| Z | 1/2" Dia x 1 1/2" lg. Blunt End | 30/40 | 1916-0005 |
| Z | 1/2" Dia x 1 1/2" lg. Blunt End w/slot | 30/40 | 1916-0007 |
| Z | 1/2" Dia x 1 1/2" lg. Sphere End | 30/40 | 1916-0006 |
| Z | 1/2" Dia x 1 1/2" lg. Sphere End w/slot | 30/40 | 1916-0008 |

Call or Check out our website www.granitecitytool.com for our full line of Electroplated Tooling!

APEXX™ Diamond Router Bits

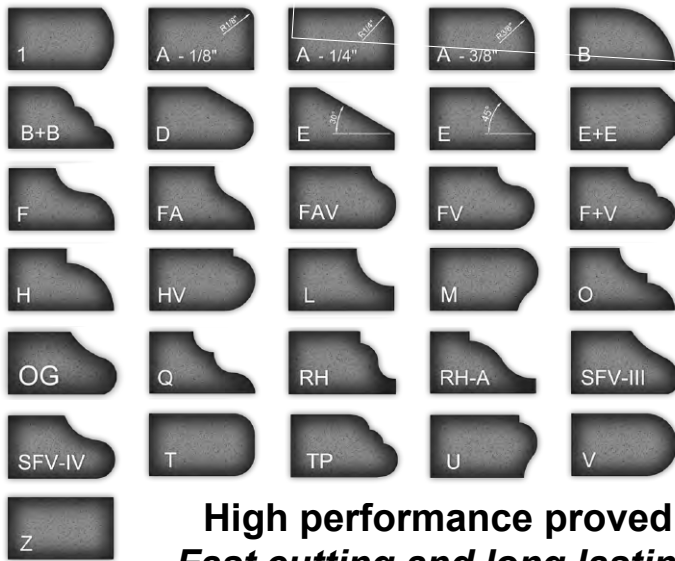

**High performance proved!
Fast cutting and long lasting!**

**MORE PROFILES AVAILABLE
- CALL ABOUT CUSTOM PROFILES**

| Shape | Size | Profile | POS 0 |
|---------|---------------|---------------|-----------|
| A | 5/8" (15mm) | Radius | 4313-1174 |
| B | 3/4" (20mm) | Half Bullnose | 4313-0590 |
| B | 1-1/4" (30mm) | Half Bullnose | 4313-0518 |
| E | 3/4" (20mm) | Bevel 45° | 4313-0030 |
| E | 1-1/4" (30mm) | Bevel 30° | 4312-0114 |
| E+E | 1-1/4" (30mm) | Double Bevel | 4313-1184 |
| F | 3/4" (20mm) | Ogee | 4313-0503 |
| F | 1-1/4" (30mm) | Ogee | 4313-0491 |
| FV | 1-1/4" (30mm) | Ogee Bullnose | 4313-1195 |
| L | 1-1/4" (30mm) | Cove | 4313-1173 |
| OG | 1-1/4" (30mm) | OG | 4313-1449 |
| SFV-III | 1-1/4" (30mm) | Ogee Bullnose | 4313-1152 |
| SFV-IV | 1-1/4" (30mm) | Ogee Bullnose | 4313-1181 |
| V | 3/4" (20mm) | Full Bullnose | 4310-0361 |
| V | 1-1/4" (30mm) | Full Bullnose | 4310-0219 |
| V | 1-1/2" (40mm) | Full Bullnose | 4313-1160 |

SEGMENTED



Other POS 0 are available upon request.

| Shape | Size | Profile | POS 1 | POS 2 |
|---------|---------------|------------------|-----------|-----------|
| 1 | 1-30 | Pencil | 4313-0466 | 4313-1506 |
| A | 1/4" | Radius | 4313-0036 | 4313-0096 |
| A | 3/8" (10mm) | Radius | 4313-0037 | 4313-0097 |
| A | 5/8" (15mm) | Radius | 4313-1175 | 4313-1176 |
| B | 3/8" (10mm) | Half Bullnose | 4313-0038 | 4313-0088 |
| B | 1/2" (15mm) | Half Bullnose | 4313-0039 | 4313-0089 |
| B | 3/4" (20mm) | Half Bullnose | 4313-0040 | 4313-0090 |
| B | 1" (25mm) | Half Bullnose | 4313-1194 | - |
| B | 1-1/4" (30mm) | Half Bullnose | 4313-0041 | 4313-0091 |
| B | 1-1/2" (40mm) | Half Bullnose | 4313-0382 | - |
| B+B | 1-1/4" (30mm) | Triple Waterfall | 4313-0234 | 4313-0235 |
| D | 1-1/4" (30mm) | D | 4313-0495 | - |
| E | 3/4" (20mm) | Bevel 45° | 4313-0042 | 4313-1191 |
| E | 1-1/4" (30mm) | Bevel 45° | 4313-0043 | - |
| E | 1-1/4" (30mm) | Bevel 30° | 4312-0115 | 4312-0117 |
| E+E | 1-1/4" (30mm) | Double Bevel | 4313-1185 | 4313-1186 |
| F | 3/4" (20mm) | Ogee | 4313-0044 | 4313-0052 |
| F | 1-1/4" (30mm) | Ogee | 4313-0045 | 4313-0053 |
| F | 1-1/2" (40mm) | Ogee | 4313-0383 | - |
| FA | 3/4" (20mm) | American Ogee | 4313-1142 | 4313-1190 |
| FAV | 1-1/4" (30mm) | Ogee Full Bull. | 4313-0321 | 4313-0464 |
| FAV | 1-1/2" (40mm) | Ogee Full Bull. | 4313-0322 | 4313-0427 |
| FV | 1-1/4" (30mm) | Ogee Bullnose | 4313-0348 | 4313-0349 |
| FV | 1-1/2" (40mm) | Ogee Bullnose | 4313-0201 | 4313-0202 |
| F+V | 1-1/4" (30mm) | Ogee+Bullnose | 4313-0419 | 4313-0420 |
| F+V | 1-1/2" (40mm) | Ogee+Bullnose | 4313-0394 | 4313-0395 |
| H | 3/4" (20mm) | Dupont | 4313-0208 | 4313-0209 |
| H | 1-1/4" (30mm) | Dupont | 4313-0212 | 4313-0301 |
| HV | 1-1/4" (30mm) | Dupont | 4313-0358 | 4313-0359 |
| HV | 1-1/2" (40mm) | Dupont | 4313-0350 | 4313-0351 |
| L | 3/4" (20mm) | Cove | 4313-0345 | - |
| L | 1-1/4" (30mm) | Cove | 4313-0330 | 4313-0331 |
| M | 1-1/4" (30mm) | Stair Tread | 4313-0442 | - |
| M | 1-1/2" (40mm) | Stair Tread | 4313-0443 | - |
| O | 3/4" (20mm) | Cove Dupont | 4313-0431 | 4313-1168 |
| O | 1-1/4" (30mm) | Cove Dupont | 4313-0220 | 4313-0221 |
| OG | 1-1/4" (30mm) | OG | 4313-1490 | 4313-1491 |
| Q | 3/4" (20mm) | Cove Ogee | 4313-0210 | 4313-0211 |
| Q | 1" (25mm) | Cove Ogee | 4313-0332 | 4313-0333 |
| RH | 3/4" (20mm) | RH | 4313-0494 | 4313-1167 |
| RH | 1-1/4" (30mm) | RH | 4313-0492 | - |
| RH-A | 3/4" (20mm) | RH-A | 4313-0328 | 4313-0329 |
| SFV-III | 1-1/4" (30mm) | Ogee Bullnose | 4313-1153 | 4313-1158 |
| SFV-IV | 1-1/4" (30mm) | Ogee Bullnose | 4313-1182 | 4313-1183 |
| T | 3/4" (20mm) | Double Eased | 4313-1165 | 4313-1166 |
| T | 30/40mm | Double Eased | 4313-0387 | - |
| TP | 1-1/4" (30mm) | Waterfall Bull. | 4313-1146 | - |
| U | 3/4" (20mm) | U | 4313-1172 | - |
| U | 1-1/4" (30mm) | U | 4313-0368 | 4313-0369 |
| V | 3/4" (20mm) | Full Bullnose | 4313-0046 | 4313-0092 |
| V | 1-1/4" (30mm) | Full Bullnose | 4313-0047 | 4313-0093 |
| V | 1-1/2" (40mm) | Full Bullnose | 4313-0048 | 4313-0094 |
| V | 5CM (50mm) | Full Bullnose | 4310-0196 | 4310-0199 |
| V | 6CM (60mm) | Full Bullnose | 4310-0160 | 4310-0194 |
| Z | 1-1/2" (40mm) | Straight | 4313-1145 | 4313-1164 |

**Not all profiles in stock.
Check for availability.**

RIVAL

Diamond Stone Profilers

| Shape | Size | Item # |
|-------|------------------|-----------|
| B | 3/16" R | 1912-0220 |
| B | 3/8" R | 1912-0221 |
| B | 1/2" R | 1912-0222 |
| B | 3/4" Half Bull | 1912-0223 |
| E | 3/16" Bevel | 4312-0104 |
| E | 3/8" Bevel | 1912-0219 |
| F | 3/4" Ogee | 1912-0056 |
| V | 3/4" Full Bull | 1912-0244 |
| V | 1-1/4" Full Bull | 1912-0245 |

- Fast stock removal, 4,000 Max RPM
- 5/8"-11 female thread for angle grinders

These cost effective stone profilers are made to work aggressively.

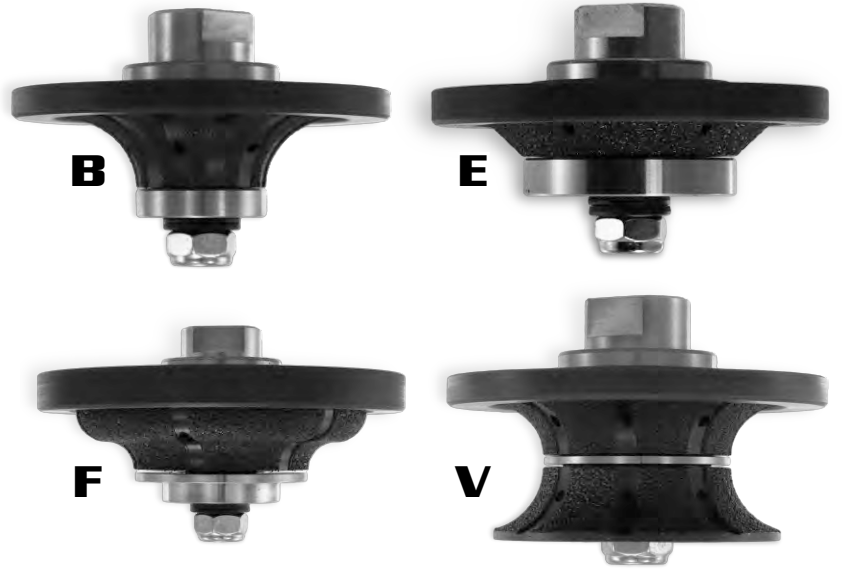

ALPHA Profiler Wheels

| Shape | Size | Item # |
|---------|--------------------|-----------|
| B | 3/16" Roundover | 4315-0003 |
| B | 3/8" Roundover | 4315-0001 |
| B | 1/2" Roundover | 4315-0013 |
| B | 3/4" Roundover | 4315-0002 |
| E | 1" Holl. Bevel | 4315-0015 |
| F Pos.0 | 3/4" Bevel | 4315-0016 |
| F Pos.1 | 3/4" Ogee | 4315-0014 |
| F Pos.0 | 1-1/4" Bevel | 4304-0114 |
| F Pos.1 | 1-1/4" Ogee | 4304-0115 |
| Q | 1/4" Recessed | 4315-0017 |
| RE | 3/8" Int. Bevel | 4315-0012 |
| V | 1-1/4" Full Bull | 4310-0101 |
| V | 1-1/2" Full Bull | 4310-0197 |
| Z | 1-1/4" Vert. Grind | 4315-0011 |
| Z | 1-1/2" Vert. Grind | 4315-0018 |



These Profilers are designed to produce everything from roundovers to vertical grinding on granite, engineered stone, and porcelain tile and slab. The nylon guide slides along the surface and the rotary toucher controls the depth of the cut to make this tool nearly "goof-proof". 3,500 max, RPM. 5/8"-11 thread.

**Husqvarna
- DMS-180
Core Drill**



1106-0020

3 Month Limited Warranty

- Used to angle drill.
- 6 " maximum bit capacity.
- Single-speed gearbox and electric overload protection.
- Mechanical clutch reduces risk of motor damage.
- 1 9" drilling stroke.

Power, watts 1,725
Voltage/amperage 115
Max bit diameter, in (mm) 6 (152)
Travel length, in (mm) 19 (483)
Spindle speed full load, rpm 540
Weight, lbs (kg) 51 (23.3)

**Husqvarna
- DMS-240
Core Drill**



1106-0017

3 Month Limited Warranty

*Core bit not included

- Core drilling in walls and floors up to 10".
- Drilling in reinforced concrete, bricks and other building material.
- Drilling ventilation and plumbing channels, waste evacuation pipes, barriers and road signs.
- Use to angle drill and stitch drill
- Includes wheels, which makes the unit easy to transport

Power, watts 2,200
Voltage/amperage 115
Max bit diameter, in (mm) 10 (254)
Travel length, in (mm) 24 (600)
Spindle speed full load, rpm 185 / 455
Weight, lbs (kg) 51 (23.3)

**M-1
Complete
Core Drill
Rigs**



20 Amp Milwaukee 450/900 RPM

1106-0026

20 Amp Milwaukee 600/1200 RPM

1106-0025

- 1" to 10" bit capacity (14" with one spacer).
- Dual switch/outlet control panel & amp meter.
- Slide handle permits drilling in tight areas.
- Streamlined base and carriage
- 2-1/2" square column with black oxidized finish.
- Quick changeover from vacuum to anchor base.
- 6" wheels for better mobility.

Core Bit Adaptor and Extensions

| Let. | Desc. | Use | Item # |
|----------|--|---|-----------|
| E | 1-1/4"-7 Female to 5/8"-11 Male Core Bit Adapter | Core Drills or any 1-1/4"-7 threaded Core Drill | 1101-0070 |
| F | 1-1/4"-7 x 12" Core Bit Extension | Core Drills | 1101-0015 |
| G | 1-1/4"-7 x 6" Core Bit Extension | Core Drills | 1101-0016 |

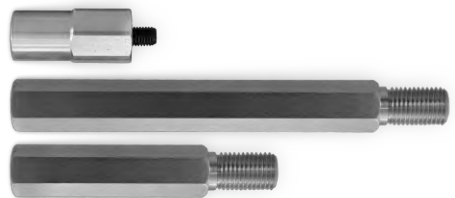

Bit Quick Disconnect



Allows for quick and easy removal of core bits. Will not let bits over tighten and lock themselves onto the core drill rig.

99-226.2-0022

Suction Rings



Includes two rings: a small ring for faucet opening holes up to 1-1/2" and a large ring for sink opening holes up to 3".

BOTH 1101-0055

Straight Shank Blind Hole Bits

| Size | Item # |
|-------|-----------|
| 1/8" | 1104-0055 |
| 3/16" | 1104-0056 |
| 1/4" | 1104-0057 |

Blind hole Bits. Non Coring bits for small hole drilling. Features 3/8" shaft for use with standard drills. Use wet only.

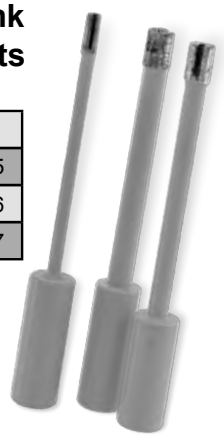



Blue Diamond Deep Hole Granite Core Bits

**1-1/4"-7 thread
13" Drill depth
Wet use only**

Fast cutting diamond core bits made to go on industrial diamond core drills with center waterfeed.

DIAMONDWRIGHT® *Made in U.S.A.*

| Size | Item # |
|--------|-----------|
| 2" | 1107-0275 |
| 2 1/4" | 1107-0276 |
| 2 3/8" | 1107-0277 |
| 2 1/2" | 1107-0278 |
| 2 3/4" | 1107-0279 |
| 3" | 1107-0265 |
| 3 1/2" | 1107-0280 |

| | |
|--------|-----------|
| 3 3/4" | 1107-0281 |
| 4" | 1107-0155 |
| 5" | 1107-0195 |
| 6" | 1107-0266 |
| 7" | 1107-0264 |
| 8" | 1107-0282 |
| 9" | 1107-0283 |
| 10" | 1107-0284 |

Blue Diamond Continuous Ring Core Drills (1-1/2" cutting depth)

5/8"-11 Female Threaded Conn.

DIAMONDWRIGHT®

Made in U.S.A.



1-1/2" Cutting Depth

| Size | Item # |
|--------|-----------|
| 7/8" | 1107-0172 |
| 1" | 1107-0157 |
| 1-1/4" | 1107-0158 |
| 1-3/8" | 1107-0152 |
| 1-1/2" | 1107-0174 |
| 1-3/4" | 1107-0176 |
| 2" | 1107-0153 |



4" Cutting Depth

| Size | Item # |
|--------|-----------|
| 7/8" | 1107-0196 |
| 1" | 1107-0197 |
| 1-1/4" | 1107-0199 |
| 1-3/8" | 1107-0200 |
| 1-1/2" | 1107-0201 |
| 1-3/4" | 1107-0203 |
| 2" | 1107-0143 |

Great for Radial Arm Machines!



5/8"-11 Female Threaded Conn.

Made in U.S.A.

Blue Diamond Segmented Core Drills

DIAMONDWRIGHT®
Wet use only

4" Cutting Depth

| Size | Item # |
|--------|-----------|
| 2-1/4" | 1107-0161 |
| 2-3/8" | 1107-0162 |
| 2-1/2" | 1107-0163 |
| 2-3/4" | 1107-0164 |
| 3" | 1107-0165 |
| 3-1/2" | 1107-0166 |
| 4" | 1107-0144 |
| 5" | 1107-0167 |
| 6" | 1107-0168 |

Wet use only

Larger cores available online.

Re-Tip and save money!

| Description | Item # |
|---|-----------|
| 1/2" shaft to 5/8-11 with 1/4" hose conn. | 1918-0083 |
| 1/2" shaft to 5/8-11 with 1/2" hose conn. | 1918-0084 |
| 1/2" shaft to 5/8-11 with garden hose conn. | 1918-0085 |
| 5/8-11 fem. to 5/8-11 male with 1/4" hose conn. | 1918-0086 |
| 5/8-11 fem. to 5/8-11 male with 1/2" hose conn. | 1918-0087 |
| 5/8-11 fem. to 5/8-11 male with garden hose conn. | 1918-0088 |
| 1/2" shaft to 1/2 gas with 1/4" hose conn. | 1918-0089 |
| 1/2" shaft to 1/2 gas with 1/2" hose conn. | 1918-0090 |
| 1/2" shaft to 1/2 gas with garden hose conn. | 1918-0091 |
| 1/4" NPT brass valve (fits any of the above) | 1918-0092 |

Blue Diamond - Water Jackets for Center Water Feed Tools

Made in U.S.A.



DIAMONDWRIGHT®

ALPHA® Dry Core Drill Bits with plated diamond sides

- Easy preparation with minimum clean-up
- Fits on most popular high-speed grinders
- Very fast cutting on granite & engineered stone
- Can be used **dry or wet**, use wet for longer bit use.

5/8-11" Threaded.
6,000-12,000 RPM

| | | | |
|--------|-----------|--------|-----------|
| 1/2" | 1105-0099 | 1-3/8" | 1105-0080 |
| 3/4" | 1105-0098 | 1-1/2" | 1105-0096 |
| 1" | 1105-0095 | 2" | 1105-0097 |
| 1-1/4" | 1105-0079 | | |



RIVAL®

Dry Side Plated Core Bits T-Type

| Size | Item # | 1-1/4" | 1105-0153 |
|--------|-----------|--------|-----------|
| 1/2" | 1105-0180 | 1-3/8" | 1105-0142 |
| 5/8" | 1105-0181 | 1-1/2" | 1105-0154 |
| 3/4" | 1105-0182 | 1-3/4" | 1105-0156 |
| 1" | 1105-0151 | 2" | 1105-0158 |
| 1-1/8" | 1105-0152 | | |

- Durable and Strong Segments
 - Side Plated allowing faster cuts and coring.
 - Can be used **dry or wet**, use wet for longer bit use.
- 5/8-11" Threaded



WHITE LIGHTNING

Diamond Core Bits

| Size | Item # |
|--------|-----------|
| 1" | 1105-0228 |
| 1-1/4" | 1105-0229 |
| 1-3/8" | 1105-0230 |
| 1-1/2" | 1105-0231 |
| 1-3/4" | 1105-0232 |
| 2" | 1105-0233 |

Designed to be the leader in segmented core bits. Super premium for ultimate strength and long life. They can be used wet or dry. 5/8-11" Threaded. 6,500 Max RPM



XPERT

Vacuum Stripe Dry/Wet Diamond Core Bits

| Size | Item # | 1-3/4" | 1105-0211 |
|--------|-----------|--------|-----------|
| 3/4" | 1105-0203 | 2" | 1105-0212 |
| 7/8" | 1105-0204 | 2-1/4" | 1105-0240 |
| 1" | 1105-0205 | 2-1/2" | 1105-0241 |
| 1-1/8" | 1105-0206 | 2-3/4" | 1105-0238 |
| 1-1/4" | 1105-0207 | 3" | 1105-0242 |
| 1-3/8" | 1105-0208 | 3-1/2" | 1105-0243 |
| 1-1/2" | 1105-0209 | 3-3/4" | 1105-0239 |
| 1-5/8" | 1105-0210 | 4" | 1105-0244 |

- Durable and Strong Segments.
 - Side Plated allowing faster cuts and coring.
 - Can be used dry or wet, use wet for longer bit life.
- 5/8-11" Threaded



CYCLONE BY DIAMAX

Cyclone Dry/Wet Vacuum Brazed Core Drill Bit

- Cores through the softest marbles clean and chip free.
- Diamond brazed technology drills fast and easy.
- Ideal for Marble. Can perform on granite with minimized life.
- Perform best wet, but can be used dry.
- Cooling slots allows for easier core removal when stuck.

| Size | Item # |
|--------|-----------|
| 1 1/4" | 1107-0578 |
| 1 3/8" | 1107-0579 |
| 1 1/2" | 1107-0577 |



XPERT

Blind Hole Bits

| Size | Item # |
|--------------|-----------|
| 1/4" (6mm) | 1104-0110 |
| 5/16" (8mm) | 1104-0111 |
| 3/8" (10mm) | 1104-0112 |
| 1/2" (13mm) | 1104-0113 |
| 9/16" (14mm) | 1104-0114 |



LARGE DIAMETER BLADES AVAILABLE BY REQUEST! BLADES UP TO 96"!

DIAMOND BLADES

RIVAL Rail Series

Low Horsepower

| Size | Arbor | Item # |
|------|----------|-----------|
| 14" | 50/60 mm | 0508-0750 |

10mm Seg.

Premium segmented laser-welded diamond blades for cutting granite, natural stone, and extremely hard bricks. **Recommended for track and rail saws.**

OZ1 Diamond Blade

Fast FREE Cutting

Wet use only
Silent Core
18mm Segment Height

| Size | Arbor | Item # |
|------|----------|-----------|
| 12" | 50/60 mm | 0508-0638 |
| 14" | 50/60 mm | 0508-0632 |
| 16" | 50/60 mm | 0508-0633 |
| 18" | 50/60 mm | 0508-0640 |

Zenesis High Speed Concrete Patterned Diamond Blades

42

| Size | Arbor | Item # |
|------|---------|-----------|
| 14" | 1"/20mm | 0513-0019 |
| 16" | 1"/20mm | 0513-0020 |
| 18" | 1"/20mm | 0513-0021 |

Rock X3 Turbo Diamond Blades

| Size | Arbor | Item # |
|------|---------|-----------|
| 14" | 1"/20mm | 0513-0029 |

for field stone

RIVAL Green Marble Blade

Green Marble Blade

Premium segmented blade that is perfect for cutting marble!
FAST CUTTING!

| Size | Arbor | Item # |
|------|---------|-----------|
| 16" | 50/60mm | 0510-0118 |



Blue Impulse III Marble Blade

Fast cutting, cost-effective, long-long lasting, smooth cutting

| Size | Arbor | Item # |
|------|----------|-----------|
| 14" | 50/60 mm | 0510-0140 |
| 16" | 50/60 mm | 0510-0145 |
| 18" | 50/60 mm | 0510-0146 |



SLASHER

DIAMONDWRIGHT Silent Core Segmented Blades

Sets the standard for high performance diamond blades.



for granite and marble Use wet only

| Diam. | Thickness | Arbor | Core | Item # |
|-------|-----------|--------|--------|-----------|
| 12" | 3.5 mm | 50 mm | Silent | 0508-0533 |
| 14" | 3.5 mm | 60 mm | Silent | 0508-0490 |
| 16" | 3.5 mm | 60 mm | Silent | 0508-0491 |
| 18" | 4 mm | 60 mm | Silent | 0508-0487 |
| 22" | 4 mm | 60 mm | Silent | 0508-0791 |
| 18" | 4 mm | 4.415" | Solid | 0508-0492 |
| 24" | 4 mm | 4.415" | Solid | 0508-0493 |



Re-Tip and Save Money!

Arbor Bushing Adapters

Take your arbor to the correct size.

| Size | Item # |
|-----------|-----------|
| 30mm-60mm | 1302-0032 |
| 40mm-60mm | 1302-0033 |
| 50mm-1" | 0501-0018 |
| 60mm-1" | 0501-0016 |
| 60mm-50mm | 0501-0026 |

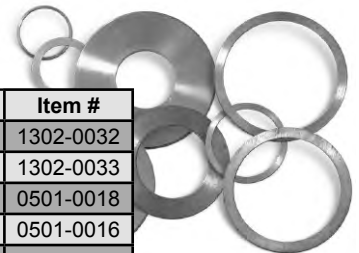

Arbor Chart - 4" to 6"

5/8"- 20mm- 7/8"- 4 Hole

Arbor Chart - 7" to 8"

5/8"- \diamond - 7/8"



XPERT
Premium Turbo Blades

| Size | Item # |
|---------------|-----------|
| 4.5" | 0508-0825 |
| 5" | 0508-0826 |
| 6" | 0508-0827 |
| 7" \diamond | 0508-0828 |



XPERT
Standard Turbo Blades

| Size | Item # |
|---------------|-----------|
| 4.5" | 0508-0840 |
| 5" | 0508-0841 |
| 6" | 0508-0842 |
| 7" \diamond | 0508-0843 |



CAYENNA Turbo Blades

| Size | Item # |
|---------------|-----------|
| 4.5" | 0508-0830 |
| 5" | 0508-0831 |
| 6" | 0508-0832 |
| 7" \diamond | 0508-0833 |

The XPERT Line of Turbo Blades are the future in Turbo Blade technology! When you want the best get XPERT! These comes in Premium, and Standard to cater to your price point.

Wet or Dry usage and can be used with Quad Adapters.

This blade will cut more aggressively than most, while the tall diamond segment provides excellent life. Designed for wet or dry use.



XPERT Combo Turbo Blades

| Size | Item # |
|------|-----------|
| 4" | 0511-0058 |
| 5" | 0511-0059 |
| 6" | 0511-0060 |

Extra Long Life!
Rock Solid Core will not flex.
Revolutionary Blade/Grinding Wheel.

Includes a **FREE** 4-Hole Adapter! 5/8"-11 Female Thread (\$20.00 Value)

Use wet or dry

| Size | Arbor | Item # |
|------|--------------------|-----------|
| 5" | 5/8" - 7/8" - 20mm | 0508-0317 |
| 7" | 5/8" - 7/8" - 20mm | 0508-0318 |

4 Hole

Great for curve cutting machines. Also the ideal blade for use with an angle grinder for cutting curved areas and light grinding. The T-segments protrude from both sides of the blade which helps prevent it from binding in the cut.

T-REX Diamond Blades

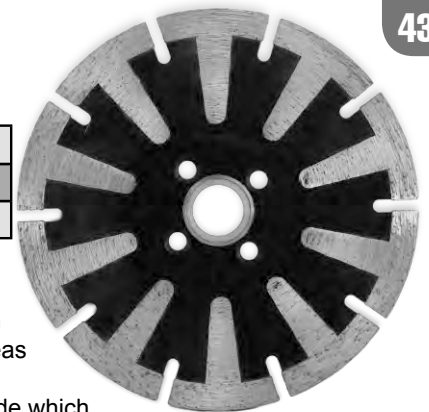

ALPHA Contour Diamond Blades

These blades are used to cut out round and oval sink holes in countertops. This new design has segments which extend lower and protrude outward to prevent binding.



Granite Contour Blades

| Size | Arbor | Item # |
|------|-------|-----------|
| 5" | 7/8" | 0508-0021 |

Use Wet Only

RIVAL Contour Diamond Blade

Great blade for sink hole cut outs.

Enhanced segments allow for faster cutting.

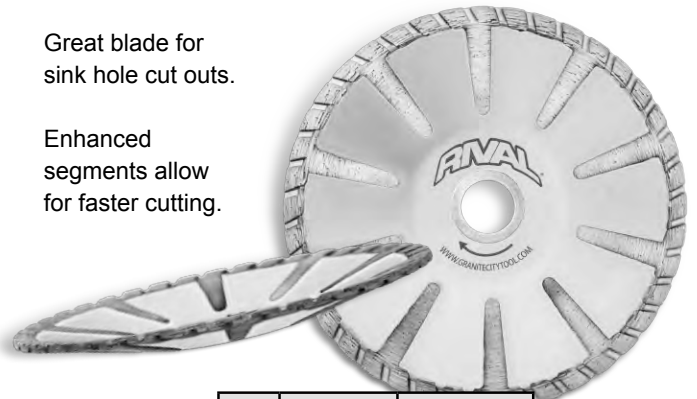

| Size | Arbor | Item # |
|------|-------------|-----------|
| 5" | 7/8" - 5/8" | 0511-0056 |

ALPHA® Professional Plus & Quad Turbo Blades

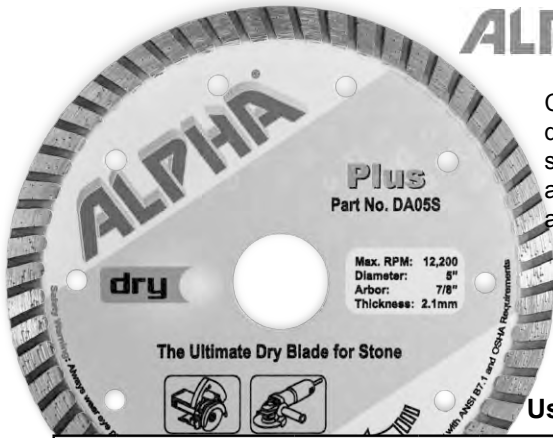

Considered to be among the finest diamond blades available in the stone industry. The Quad blades are drilled for the flush mount adapters, the Plus blades are not.



Use wet or dry

Use wet or dry

| PLUS Blades | | | | | |
|-------------|--------------------|-----------|------|-----------|-----------|
| Size | Arbor | Item # | Size | Arbor | Item # |
| 4" | 20mm - 5/8" | 0508-0001 | 8" | ◇ - 5/8" | 0508-0017 |
| 4.5" | 7/8" - 20mm - 5/8" | 0508-0005 | 9" | 1" - 5/8" | 0508-0022 |
| 5" | 7/8" - 20mm - 5/8" | 0508-0008 | 10" | 5/8" | 0508-0024 |
| 6" | ◇ - 5/8" - 1/2" | 0508-0011 | 12" | 1" - 20mm | 0508-0027 |
| 7" | ◇ - 5/8" | 0508-0013 | | | |

| QUAD Blades | | |
|-------------|-------|-----------|
| Size | Arbor | Item # |
| 4" | 20mm | 0508-0002 |
| 5" | 20mm | 0508-0009 |
| 6" | 20mm | 0508-0012 |
| 7" | 20mm | 0508-0014 |
| 8" | 20mm | 0508-0018 |

DIAMAX Cyclone Granite Turbo Diamond Blades

Engineered to be the fastest cutting turbo blade in the industry. Extremely clean and sharp precision cuts.

RIVAL SP Turbo Blades

A Premium blade fast becoming the new industry Standard. Providing fast clean cuts! Great life & speed!



| Size | Item # |
|------|-----------|
| 4" | 0508-0666 |
| 4.5" | 0508-0667 |
| 5" | 0508-0619 |
| 6" | 0508-0668 |
| 7" ◇ | 0508-0669 |
| 8" ◇ | 0508-0609 |



| Size | Item # |
|------|-----------|
| 4.5" | 0508-0780 |
| 5" | 0508-0769 |
| 6" | 0508-0770 |
| 7" ◇ | 0508-0781 |
| 8" ◇ | 0508-0782 |

Use wet or dry

| |
|-------------------------------|
| Arbor Chart - 4" to 6" |
| 5/8" - 20mm - 7/8" - 4 Hole |

| |
|-------------------------------|
| Arbor Chart - 7" to 8" |
| 5/8" - ◇ - 7/8" |

Use wet or dry

SAMURAI DIAMOND BLADES

| Size | Item # |
|---------------|-----------|
| 4.5" | 0508-0097 |
| 5" | 0508-0100 |
| 6" | 0508-0418 |
| 7" \diamond | 0508-0102 |
| 8" \diamond | 0508-0104 |

See Arbor Chart



Use wet or dry

Laser welded Segments protrude out from the sides and some are longer than others which prevents binding, increases the cutting speed and provides a smooth cut.

TWISTER Turbo Blades

| Size | Item # |
|---------------|-----------|
| 4" | 0508-0909 |
| 4.5" | 0508-0910 |
| 5" | 0508-0911 |
| 6" | 0508-0912 |
| 7" \diamond | 0508-0913 |
| 10" | 0508-0914 |
| 12" | 0508-0916 |
| 14" | 0508-0915 |

See Arbor Chart



Use wet or dry

12-14" Arbor 50/60mm - 1"

This blade is designed for fast cutting performance and extruded diamond sides to prevent binding in the cut.

Arbor Chart - 4" to 6"

5/8"- 20mm- 7/8"- 4 Hole

Arbor Chart - 7" to 8"

5/8"- \diamond - 7/8"

Arbor Chart - 9" to 10"

1" - 7/8" - 5/8"

RIVAL[®] Electroplated Marble Blades

Premium marble blade with multiple slots to increase cutting speed.

Perfect for softer stones!



| Size | Item # |
|---------------|-----------|
| 4.5" | 0510-0141 |
| 5" | 0510-0142 |
| 6" | 0510-0143 |
| 7" \diamond | 0510-0144 |

See Arbor Chart

RIVAL[®] Diamond Continuous Rim Porcelain/Stone Blades

These Premium blades are designed to cut all types of stone and porcelain tiles.

Dry/Wet Cutting
Fast Cutting!



Use wet only

| Size | Item # | 8" \diamond | Item # |
|---------------|-----------|---------------|------------------|
| 4" | 0510-0103 | 10" | 0510-0109 |
| 4.5" | 0510-0104 | 12" | 0510-0110 |
| 5" | 0510-0105 | 14" | 0510-0111 |
| 6" | 0510-0106 | | |
| 7" \diamond | 0510-0107 | 12-14" Arbor | 1" - 7/8" - 5/8" |

See Arbor Chart

XPERT Tuck Point Rodding Diamond Blades



7/8"-5/8" Arbor

The kerf is used for slotting and cutting grooves and notches in granite and other stones. Can also be used for cleaning out mortar joints on masonry structures.

| Size | Thick | Arbor | Item # |
|------|-------|----------------|-----------|
| 3" | 1/4" | 7/8"-20mm-5/8" | 0508-0615 |
| 4" | 1/4" | 7/8"-20mm-5/8" | 0508-0419 |
| 5" | 1/4" | 7/8"-20mm-5/8" | 0508-0421 |
| 7" | 1/4" | 7/8"-20mm-5/8" | 0508-0628 |

Flush Mount Adapters

Flush adapters make the back side of the blade flush allowing difficult flush cuts to be achieved. Very popular with sculptors, stone and finish cutters using right angle grinders for surface relief cutting, pitching lines and intricate cutting. The 4-hole adapter is for 4" - 7" blades. The 8-hole adapter is for 8" - 14" blades. Most of the blades we sell accommodate these adapters' hole patterns, just ask when ordering.



| Desc. | Item # | | |
|--------------|-----------|------------------------|-----------|
| | | 4-Hole Stainless Steel | 0501-0045 |
| 8-Hole Alum. | 0501-0055 | 4-Hole Brass | 0501-0021 |

ALPHA Hot-Rod Diamond Blades for Countertops



Use wet only

These blades are suited for all categories of granite, and marble. The thick segments provide the perfect size to accommodate the stainless steel and plastic rods, used to stabilize thin stone

| Size | Thick | Type | Arbor | Item # |
|------|-------|---------|-------|-----------|
| 3" | 1/8" | Granite | 20mm | 0511-0033 |
| 3" | 1/4" | Granite | 20mm | 0511-0001 |

ALPHA Quad Drive Adapters



Works on Alpha Blades.

| Description | Item # |
|---------------------------|-----------|
| 5/8"-11 Thread/Quad Drive | 0501-0001 |



| | | | | | |
|---|---|-----------|----|--|-----------|
| 1 | 1/2" Shaft to 5/8-11 Male Thread | 4308-0084 | 7 | 1/2 Gas Male Thread to Hole for 3/8" Shaft** | 4308-0099 |
| 2 | 3/8" Shaft to 5/8-11 (M) | 4308-0122 | 8 | 1/2 Gas Male to Hole For 1/2" Shaft | 4308-0101 |
| 3 | 5/8-11 Fem. to 5/8-11 Male Ext. W/Waterfeed | 4308-0115 | 9 | 1/2" Shaft to Ghines Female (M10X1.5) | 4308-0085 |
| 4 | 5/8-11 Female to Ghines Female (M10X1.5) | 4308-0087 | 10 | 1/2 Gas Male to Ghines Female (M10X1.5) | 4308-0097 |
| 5 | 1/2 Gas Male to 5/8-11 Male Router | 4308-0095 | 11 | 5/8-18 Male Machine to 5/8-11 Male Thread | 4308-0093 |
| 6 | 1/2 Gas Male to Hole For 1/4" Shaft | 4308-0100 | 12 | 5/8 x 18 Male to 1/2 Gas Female | 4308-0083 |

CALL US FOR ANY ADAPTER YOU NEED - 800-328-7094

Makita 5477NB 7-1/4" Hypoid Saw

Arbor: 5/8"
 Blade Diameter: 7-1/4"
 Max. Cut - 90°: 2-3/8"
 Max. Cut - 45°: 1-3/4"
 Max. Cut - 50°: 1-9/16"
 No Load Speed: 4,500 RPM
 15 Amps (120V)



4903-0023 **Worm Drive, Heavy Duty**

1 Year Limited Warranty

Skil® HD5860 8-1/4" Saw

1 Year Limited Warranty



Arbor: 5/8"
 Blade Diameter: 8-1/4"
 Max. Cut - 90°: 2-7/8"
 Max. Cut - 45°: 2-1/4"
 No Load Speed: 4,300 RPM
 13 Amps (120V)

4915-0005

Worm Drive, Heavy Duty

Makita 4114 14" Angle Cutter

1 Year Limited Warranty

Specifications:

Power: 120V - 15 Amps
 No-load speed: 3,500 RPM
 Cutting disk diameter: 5"
 Arbor: 1"
 Max. cutting depth: 5"
 Weight: 23 lbs



4905-0052

Built-in vacuum attachment port for efficient removal of dust and debris

Rubber shield helps keep debris away from operator and from entering the motor

ALPHA® AWS-125 - 5" Wet Stone Cutter

180 Day Limited Warranty

Accepts contour blades for sink cutouts



Specifications:

- Volts: 110V
- Power: 1200W, 11.2 Amp
- Speed: 12,000 RPM
- Arbor 7/8"/22mm
- Max. cutting depth: 1-5/8"**
- Weight: 7.2 lbs

AWS-125 Saw 4903-0001

The AWS-125 is a perfect sink cut-out machine. Put on the 5" contour blade. Draw the sink-hole with our template and white paint marker. Remove the template and cut. It should take less than five minutes to cut out a standard sink hole! You will be amazed how easy it is to cut a sink hole with this machine.

Husqvarna 14" K760 II Power Cutter Saw

Maximum power: 5 hp
 No load speed: 9,000 RPM
 Maximum spindle speed: 4,650
 Max. cutting depth: 4 / 5 "
 Wheel diameter: 12 / 14 "
 Arbor: 13/16"
 Net weight: 21.6 lbs

1 Year Limited Warranty

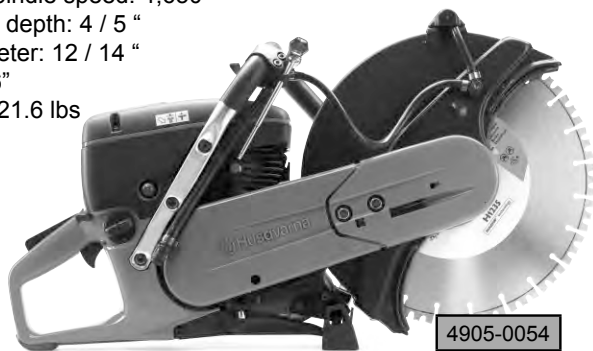

4905-0054

Concrete Blade on
 ← **Page 42**



Tool Picture Shows Optional Diamond Blade
Ask about our Blade Specials!

Husqvarna 14" K3000 Electric Wet Cut-Off Saw II

Maximum power: 2.7 hp
 Motor/Engine: 15A, 120V Electric
 Volt: 120
 Max. cutting depth: 5"
 Wheel diameter: 14"
 Arbor: 13/16"
 Net weight: 18.7

4905-0058

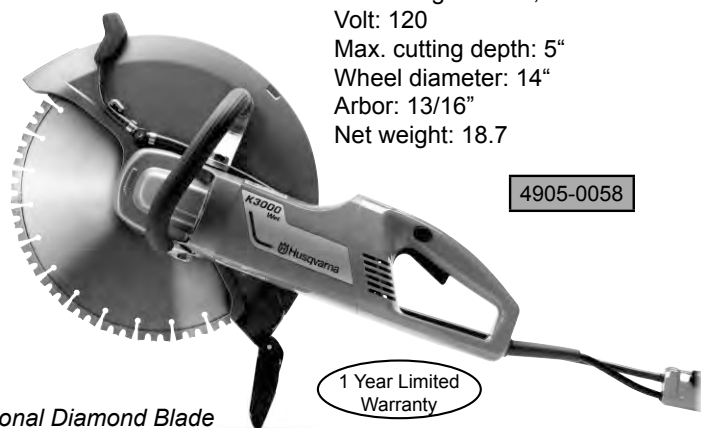

1 Year Limited Warranty



MANTA 100 Aluminum Saw

Specifications:

Motor: 115V, 1PH, 2.5hp
 RPM: 3,200 RPM
 Blade Diameter: 14"
 Arbor Size: 1"
 Cutting Depth: 4.25"
 Cutting Length: 40"
 Weight: 158 lbs.

4910-0017

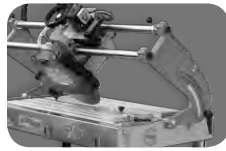

Optional Side Table

4914-0106



- **Extremely portable - one person transport**
- **Rust proof light weight aluminum**
- **Precision cuts at 90° and 45°**
- **Dust free cutting with water reclaiming table**



MANTA 150ED Steel Saw

Specifications:

Motor: 115V, 1PH, 2.5hp
 RPM: 3,200 RPM
 Blade Diameter: 14"
 Arbor Size: 1"
 Cutting Length: 60"
 Cutting Depth: 4.25"
 Weight: 396 lbs.

4910-0018

Strong, accurate, versatile and inexpensive. By positioning the saw head on linear ball bearings; riding two chrome plated ground bars, the Manta saws cut extremely accurately. Equipped with submersed pump for blade cooling. Tilting head for 45° cuts.

1 Year Limited Warranty

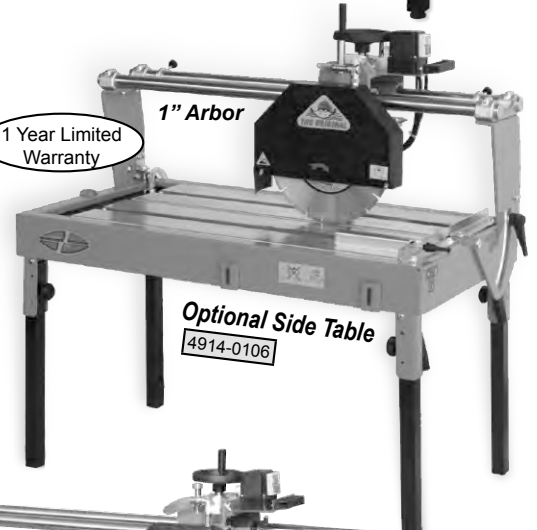

MANTA 150ED SPECIAL Steel Saw

Specifications:

Motor: 220V, 1PH, 3hp
 Arbor: 30mm
 RPM: 1,750 RPM
 Blade Diameter: 14"
 Cutting Depth: 6"
 Cutting Length: 60"
 Weight: 407 lbs.

4910-0032

Strong, accurate, versatile and inexpensive. By positioning the saw head on linear ball bearings; riding two chrome plated ground bars, the Manta saws cut extremely accurately. The Manta saws come equipped with a built in water pan, submersible pump and easily removable drain plug. The hand wheel at the top of the saw is used for raising and lowering of the cutting head. The saw head is inclinable to make mitre cuts up to 45 degrees.

1 Year Limited Warranty

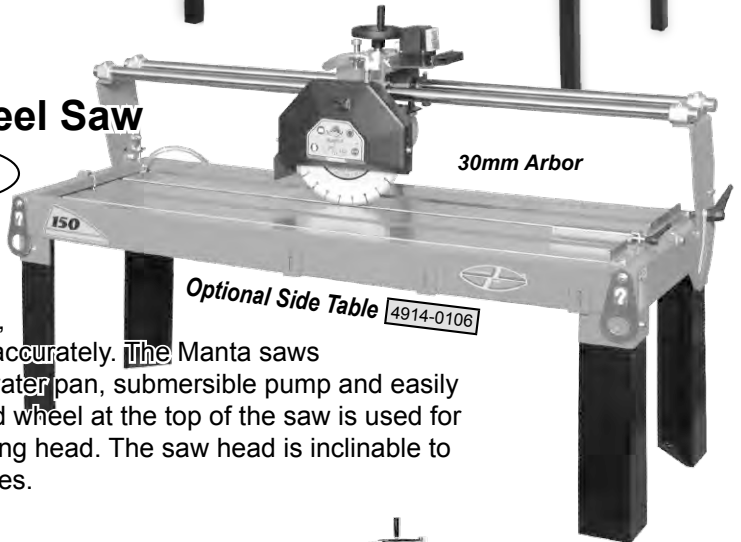

MANTA TB 200LX Steel Saw

Specifications:

Motor: 220V, 1PH, 3hp
 Arbor: 30mm
 RPM: 1,750 RPM
 Blade Diameter: 16"+
 Cutting Depth: 5"
 Cutting Length: 79"
 Weight: 525 lbs.

4910-0038

Strong, accurate, versatile and inexpensive. By positioning the saw head on linear ball bearings; riding two chrome plated ground bars, the Manta saws cut extremely accurately. Manual travel by way of hand-wheel. Equipped with submersed pump for blade cooling. Tilting head for 45° cuts.

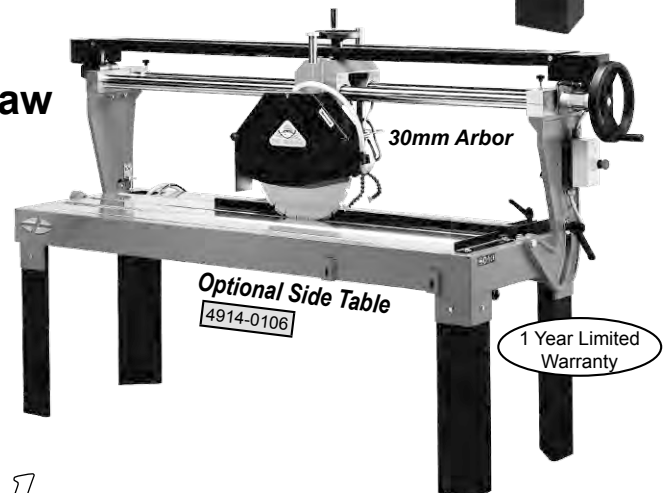



MANTA 150-650LX Steel Saw

Specifications:

Motor: 220V, 3PH, 5.5 hp
 RPM: 1,750 RPM
 Blade Diameter: 26"+
 Min Blade Diameter: 22"
 Arbor Size: 40mm
 Flange: 6.5"
 Cutting Length w/ guard: 40"
 Cutting Length wo/ guard: 47"
 Cutting Depth: 10" MAX
 Weight: 440 lbs.

4910-0039

Robust, accurate, versatile and economical, this saw is built for cutting blocks for fixtures and fittings. Extremely accurate with head sliding by means of linear ball bearings on two chrome-plated and ground bars. Cutting control through belt drive of the head driven by a hand wheel positioned at the "operator station". It is equipped with a submersed pump inside the base for blade cooling, water is reclaimed. Vertical motion head by means of hand wheel for stable and fast control. Inclined head for 45 degree cuts.

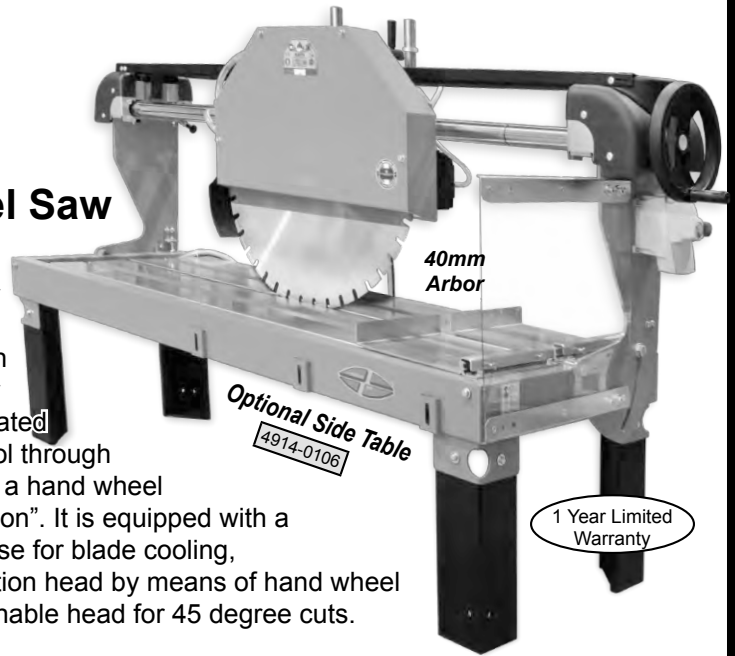

STONE SAWS

Today's tile and stone pieces are larger and more expensive than in years past. Consequently, architects and their clients want the pieces set very close together for that striking "slab look". This requires accurate, chip free cutting performance. The Combi 250VA delivers this performance for the most demanding installations, day after day. GUARANTEED!



CombiCut 250VA 10" Tile & Stone Saw

Specifications:

- Blade diameter: 10"
- Arbor Size: 5/8"
- Cutting Length: 28"
- **Cutting Depth at 90°: 2 1/2"**
- Cutting Depth at 45°: 1-1/4"
- No load speed: 2,800 RPM
- 15 Amps, 110V
- 1-1/2 HP

4911-0055

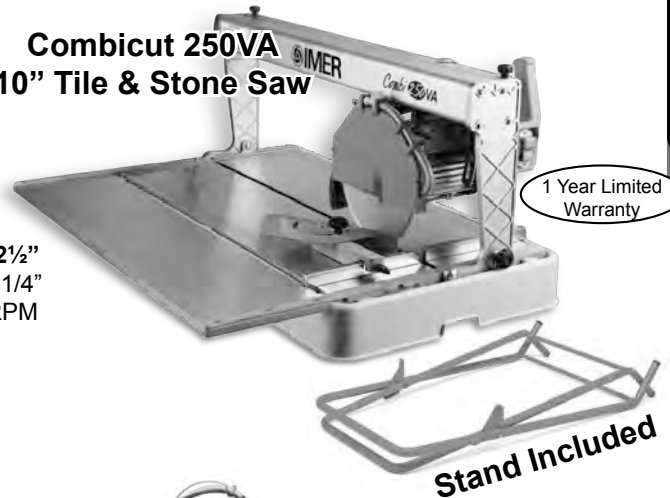

49

This is The Best Tile, Stone & Masonry Saw in the World! The all new 350/1200 iPower is more powerful and accurate than ever before. The new 4 h.p. motor combined with the laser guide ensures that cuts are made quickly and accurately. Tile and stone installers, masons, precast fabricators, landscapers and general contractors across America are putting the 350/1200 iPower to the test. Cut 24"x24" pavers on a diagonal, 48" pieces of marble and granite up to 3/4" in depth. This saw is versatile and reliable.



CombiCut 350/1200 iPower 14" Tile & Stone Saw

Specifications:

- Blade diameter: 14"
- Arbor Size: 1"
- Cutting Length: 48"
- **Cutting Depth at 90°: 4 3/4"**
- No load speed: 2,800 RPM
- 15 Amps, 220V
- 4 HP

4910-0034

FREE FREIGHT LOWER 48!



IMER[®] Masonry 900
36" Blade
U.S.A., Inc.

Motor: 10 HP, 440V, 3-Phase
 Blade RPM: 910
 Max Blade size: 36"
Max depth cut: 15"
 Length of cut: 2ft 2in
 (w/plunge cut)
 Weight: 700 lbs.



4905-0026

This stone saw is made to cut through large field and quarry stone. It also has the ability to work with all types of precast products. With a 10 h.p. gear drive motor cuts up to 15" in depth are no problem. Load up the saw with stone or precast pieces weighing hundreds of pounds... this saw can take it!

IMER[®] Masonry 700
8" Blade
U.S.A., Inc.

Motor: 7.5 HP, 220V, 1 or 3-Phase
 Blade RPM: 1,700
 Max Blade size: 28"
Max depth cut: 11"
 Weight: 440 lbs.



4907-0027

This saw allows the operator to cut 8" and 10" blocks in a single pass.

The frame and cutting tray are hand fabricated heavy duty steel, while the ergonomic design allows the operator to load up the saw with a lot less effort than our competitors' saws.

OGYU
manufacturing Inc.

Diamond Wire Saws

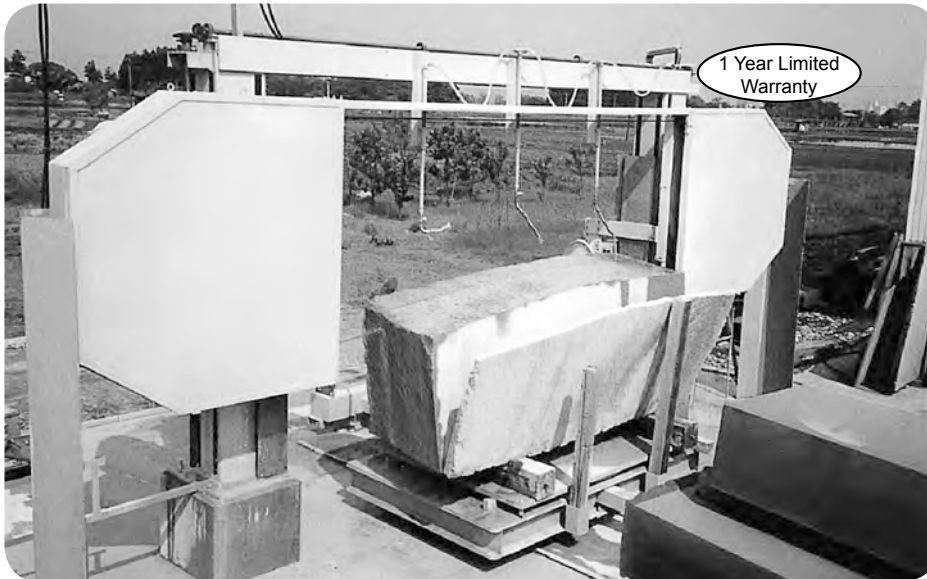

Call for Pricing & Freight Quotes

| Type | Item # |
|------------|-----------|
| SDW-S1530 | 4912-0033 |
| EEW-L2035 | 4912-0034 |
| EDW-L2035 | 4912-0035 |
| SDW-M1535 | 4912-0036 |
| SDW-2535 | 4912-0037 |
| EDW4-L3050 | 4912-0038 |
| EDW4-L4040 | 4912-0040 |
| EEW-SS120 | 4912-0025 |
| EEW-S1530 | 4912-0026 |
| EDW-SS120 | 4912-0027 |
| EEW-M1535 | 4912-0028 |
| EDW-S1530 | 4912-0029 |
| EDW-M1535 | 4912-0031 |
| SDW-SS120 | 4912-0032 |

OGYU makes a wide variety of Diamond Wire saws to cut slabs of various dimensions. Call us for a quote based on the sizes you cut. The saw can be ordered to cut vertically only, or both vertical and horizontal. The vertical and horizontal cut models can cut virtually any shape with the use of an optical scanner. Please call us for a quote on the model that is right for you.

Diamond Wire Speed-Changeable for 2 speeds
 *Economy Mode - 30m/s (98' per second)
 *Super Mode - 42m/s (138' per second)
 Diamond Wire Length: Approx. 13M (42')
 Water Volume: 60L/min. (16gal./min)
 Options *Auto Wedge Insertion System
 *Auto Feeding System (3 kinds of thickness)
 Maximum Stone Size: 1.2M (H) x 1.5M (W) x 2.8M (D)
 {4' (H) x 5' (W) x 9' (D)}
 Wheel Diameter: f1000mm x 4 pcs. (f39" x 4 pcs.)
 Motors: Main Shaft, 15kW (20Hp) Cart Drive, 0.75kW (1Hp)
 Diamond Wire Tension Device
 Air-Hydraulic Conversion Type
 *This device requires an air compressor with pressure 125psi.
 Cart Size: 1200mm (W) x 2400mm (D) {4' (W) x 8' (D)}
 Cart Drive Method By square thread
 Rail Length 5M (16')



**Horizontal
Diamond
Wire Saw**

4912-0044

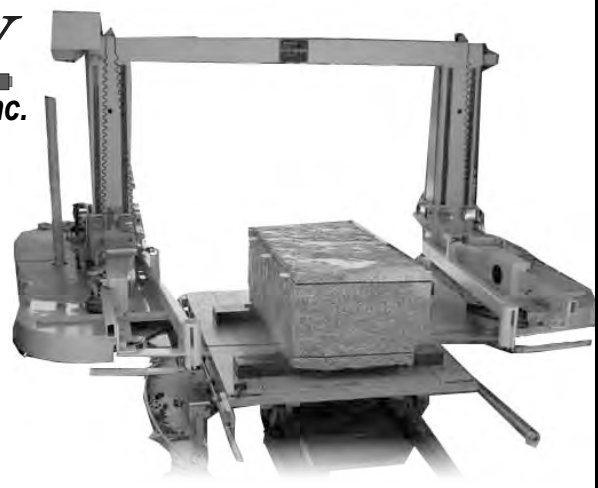

The OGYU Horizontal diamond wire saw is an excellent saw for slab cutting. The horizontal cutting feature allows for cutting a block of stone faster than a vertical wire saw and it also has an auto wedge insertion system. This saw is also capable of cutting various size slabs in the same cutting program.

Please call for a quote and a free video on this model of diamond wire saw.

Specifications:

Effective cut size:
 4.9'(y) x 4.9'(x) x 9.8"(high)
 Wire Length: 23'
 Spindle Motor: 7.5 HP
 X-Axis driving motor: 1/2 HP
 Y-Axis driving motor: 1/2 HP
 Tracing Method: Optical
 Overall Weight: 10,141 lbs



4912-0039

**Call for Pricing &
Freight Quotes**

**Vertical Curve
Diamond Wire Saw**



CUT ANY SHAPE!!

**Principle of
Cutting Curve**



The greatest feature of the diamond wire is the constant performance in all cutting directions of 360°.

Tracing Unit



The diamond wire moving linearly front and rearwards is moved along the vertical axis (longitudinal direction) of the tracing unit by the stainless wire of 1mm. The rotation of the stone moving square screws is moved along the horizontal axis (lateral direction) of the tracing unit.

OGYU Woven Diamond Wire



**Woven, not spliced.
For: granite, marble,
limestone, and
all natural stone.**

Sold by the loop

Technowire Diamond Wire



Super Premium
Diamond Wire - **8.3mm**
Super Premium
Diamond Wire- **11.3mm**

Sold by the meter

| Item # | Description |
|-----------|-----------------------------------|
| 4914-0027 | 9mm Woven -Sandstone |
| 4914-0028 | 10.5mm Woven - Sandstone |
| 4914-0082 | 9mm Woven - Limestone (Yellow) |
| 4914-0083 | 10.5mm Woven - Limestone (Yellow) |
| 4914-0084 | 9mm Woven - Granite (Green) |
| 4914-0085 | 10.5mm Woven - Granite (Green) |
| 4914-0091 | 9mm Woven - Marble (Red) |
| 4914-0092 | 10.5mm Woven - Marble (Red) |
| 4914-0098 | 6.5mm Woven - Granite Dario |
| 4914-0114 | 9mm Woven - Concrete |
| 4914-0115 | 10.5mm Woven - Concrete |
| 4914-0118 | 11.3mm - Hard Granite Bond |
| 4914-0125 | 8.3mm - Hard Granite Bond |
| 4914-0127 | 8.3mm - Indiana Limestone |
| 4914-0156 | 10.5mm Woven - High Speed |
| 4914-0157 | 9mm Woven - Travertine |

RIVAL Diamond Wire



| Diam. | Item # |
|---------|-----------|
| 11mm | 4914-0296 |
| 10.5 mm | 4914-0297 |
| 8.8 mm | 4914-0298 |

**37 Beads/M, Plastic
Please specify material using on.**

**Hydraulic
Crimper**

4914-0299



Complete
with Dies

**Wire
Crimper**

4914-0300



Makita PW5001C 4" Variable Speed Wet Stone Polisher



- GFI Protected
- Speed: 2,000 - 4,000 RPM
- 120 Volts, 7.9 Amps
- Spindle Thread: 5/8" - 11"
- Overall Length: 12-1/4"
- Net Weight: 4.6 lbs.

1 Year Limited Warranty

1909-0079 | 3904-0055 Carbon Brush SET

metabo PWE11-110 4" Wet Polisher



- No Load Speed: 1,700 - 5,400
- Backing pad size: 4"-5"
- Amps: 9.6
- Spindle thread: 5/8" - 11
- Tool length: 12.7"
- Net Weight: 5.2 lbs.

3 Year Limited Warranty



1909-0198 | 99-498-0016 Carbon Brush

FLEX LE-12-3-100 WET Polisher



- Variable Speed:** 1,200-3,700 RPM
- 120 Volts, 9.3 Amps
 - Spindle Thread: 5/8"-11
 - Max disc diameter: 5"
 - Net Weight: 5.29 lbs.

1 Year Limited Warranty

3905-0036 | 99-765-0146 Carbon Brush

FLEX L12-3-100 WET Polisher



- Single Speed:** 3,700 RPM
- 120 Volts, 9.3 Amps
 - Spindle Thread: 5/8"-11
 - Max disc diameter: 5"
 - Net Weight: 5.29 lbs.

1 Year Limited Warranty

3905-0037 | 99-765-0146 Carbon Brush

FLEX LW 603 VR 5" Variable Speed Angle Polisher



- No Load Speed: 1,000-2,800 RPM
- 120 Volts, 13 Amps
- Spindle Thread: 5/8"-11
- Max disc diameter: 5"
- Net Weight: 7.5 lbs.

1 Year Limited Warranty

1909-0028 | 99-765-0104 Carbon Brush

FLEX LW 1509 4.5" High Speed Wet Angle Grinder



- No Load Speed: 8,300 RPM
- 120 Volts, 7.1 Amps
- Spindle Thread: 5/8"-11
- Max disc diameter: 4.5"
- Net Weight: 4.8 lbs.

1 Year Limited Warranty

1909-0041 | 1918-0018 Carbon Brush

ALPHA WDP-320 5" Variable Speed Electric Polisher



- Speed: 700-2,500 RPM
- 120 Volts, 7 Amps
- Spindle Thread: 5/8"-11
- Max disc diameter: 5"
- Net Weight: 7.3 lbs.

1 Year Limited Warranty

1909-0219 | 99-030-0227 Carbon Brush SET

ALPHA VSP-320 5" Variable Speed Wet Polisher



- Speed: 700-2,500 RPM
- 120 Volts, 7 Amps
- Spindle Thread: 5/8"-11
- Max disc diameter: 5"
- Net Weight: 7.3 lbs.

1 Year Limited Warranty

1909-0161 | 99-030-0227 Carbon Brush SET

Makita 9564CV 4.5" Angle Grinder

1 Year Limited Warranty



- Grinding Wheel: 4.5"
- Wire Cup Brush: 3"
- Sanding Disc: 4.5"
- 2,800-10,500 RPM
- 120 Volts, 12 Amps
- Spindle Thread: 5/8"-11
- Overall Length: 11-3/4"
- Net Weight: 4.0 lbs.

1909-0179 3904-0055 Carbon Brush SET

Makita 9565CV 5" Variable Speed Angle Grinder

1 Year Limited Warranty



- Grinding Wheel: 5"
- Wire Cup Brush: 3"
- Sanding Disc: 5"
- 2,800-10,500 RPM
- 120 Volts, 12 Amps
- Spindle Thread: 5/8"-11
- Overall Length: 11-3/4"
- Net Weight: 4.0 lbs.

Super Joint System (SJS) helps prevent gear damage

1909-0108 3904-0055 Carbon Brush SET

FLEX L 1506 VR 5" Angle Grinder



- No Load Speed: 2,200-6,800 RPM
- 120 Volts, 10 Amps
- Spindle Thread: 5/8"-11
- Max disc diameter: 5"
- Net Weight: 4.2 lbs.

1 Year Limited Warranty

1909-0013 1918-0018 Carbon Brush

FLEX L 3410 VRG 5" Variable Speed Angle Grinder



- No Load Speed: 3,000-11,000 RPM
- 120 Volts, 10 Amps
- Spindle Thread: 5/8"-11
- Max disc diameter: 5"
- Net Weight: 4.1 lbs.

1 Year Limited Warranty

1909-0084 99-765-0057 Carbon Brush

Makita 9557NB 4.5" Angle Grinder

1 Year Limited Warranty



- No Load Speed: 11,000 RPM
- 120 Volts, 7.5 Amps
- Spindle Thread: 5/8"-11
- Length: 10-5/8"
- Net Weight: 3.5 lbs.

1909-0123 99-477-0084 Carbon Brush

metabo WE14-125 VS Electric Angle Grinder

1 Year Limited Warranty

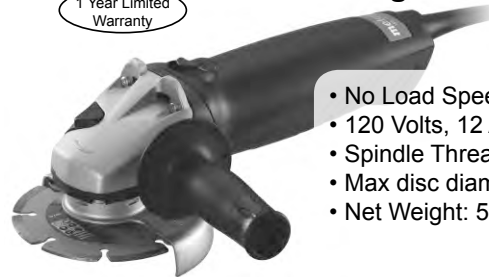

- No Load Speed: 3,000-10,000 RPM
- 120 Volts, 12 Amps
- Spindle Thread: 5/8"-11
- Max disc diameter: 5"
- Net Weight: 5.5 lbs.

1909-0151 99-498-0017 Carbon Brush SET

FLEX Flex LE 9-10-125 5" Variable Speed Grinder

1 Year Limited Warranty



- No Load Speed: 6,000-10,000 RPM
- 120 Volts, 7.9 Amps
- Spindle Thread: 5/8"-11
- Max disc diameter: 5"
- Net Weight: 4.3 lbs.

1909-0200 99-765-0167 Carbon Brush

metabo W18 LTX-115 5.2 Cordless Angle Grinder

1 Year Limited Warranty



- No Load Speed: 8,000 rpm
- Max wheel diameter: 4 1/2"
- Battery pack voltage/capacity 18V/5.2 Ah
- Spindle thread: 5/8" - 11
- Tool length: 13"
- Tool Weight: 5.3 lbs.

Includes: 2 Batteries, & Charger

1909-0209 99-498-0027 Carbon Brush

| | |
|---------|-----------|
| Battery | 1918-0125 |
| Charger | 1918-0126 |

ALPHA[®] AIR-680 Pneumatic Polisher



1 Year Limited Warranty

REAR Exhaust

- Air Consumption: 15 CFM
- Air Pressure: 85 PSI
- Speed: 4,000 RPM
- Weight: 2.64 lbs.
- Spindle: 5/8"-11

3905-0018

ALPHA[®] AIR-300 Mini Pneumatic Polisher



90 Day Limited Warranty

REAR Exhaust

- Air Consumption: 10 CFM
- Air Pressure: 87 PSI
- Speed: 5,800 RPM
- Weight: 1.60 lbs.
- Spindle: 5/8"-11
- Air Inlet: 1/4" NPT

3905-0035

S-9 Pneumatic Water Polisher



90 Day Limited Warranty

- Spindle: 5/8"-11
- Speed: 4,500 RPM
- Air Usage: 16 CFM at 90 PSI
- 4" Grinding Wheel Size
- Net Weight: 3.3 lbs

BEST TOOL IN ITS CLASS, AT THE BEST PRICE!

1909-0071



BD-5000 5" Wet Air Grinder



90 Day Limited Warranty

REAR Exhaust

- Shaft Thread: 5/8"-11
- RPM: 10,000
- Air Usage: 15 CFM at 90 PSI
- Air Inlet: 1/4" NPT
- Output: 650W
- Length: 9 in.
- Max. Disc Size: 5"
- Weight: 4 lbs.

1909-0186

SA2 Pneumatic Water Polisher



90 Day Limited Warranty

REAR Exhaust

- Spindle: 5/8"-11
- Speed: 4,500 RPM
- Air Usage: 16 CFM at 90 PSI
- 4" Grinding Wheel Size
- Net Weight: 3 lbs.

1909-0210

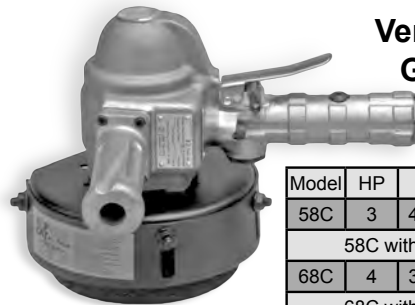

Vertical Air Grinder

1 Year Limited Warranty

| Model | HP | RPMs | Item # |
|--------------------|----|-----------------|-----------|
| 58C | 3 | 4,500-9,000 RPM | 1909-0100 |
| 58C with Waterfeed | | | 1909-0102 |
| 68C | 4 | 3,000-8,000 RPM | 1909-0101 |
| 68C with Waterfeed | | | 1909-0103 |

Very powerful 3 HP or 4 HP vertical grinder is designed for continuous heavy-duty grinding applications. Perfect tool for 6" silicon carbide wheels. Available with or without automatic waterfeed system. 24 CFM, 90 PSI. 5/8"-11 spindle.

CatOil

CatOil is the superior industrial non-synthetic lubricant for your compressors, tools and robotics.



| | |
|-------|------------|
| 4 oz | 99-03-0067 |
| Quart | 99-03-0068 |

GISON GPW-216 Air Wet Stone Grinder



90 Day Limited Warranty

- Air Consumption: 26 CFM
- Max Speed : 7,000 rpm
- Weight: 3.20 kgs
- Spindle Thread : 5/8"-11, M14
- Air Inlet: 3/8"

1909-0051

GISON GPW-212 Air Wet Stone Polisher



90 Day Limited Warranty

- Air Consumption: 22 CFM
- Max Speed : 2,800 rpm
- Weight: 2.20 kgs
- Spindle Thread : 5/8"-11, M14
- Air Inlet: 1/4"

1909-0189



9227C 7" Variable Speed Polisher



- Sanding Disc 7"
- Wool Bonnet 7"
- No Load RPM 600-3,000
- 120 Volts, 10 Amps
- Spindle Thread: 5/8"-11
- Overall Length: 18-1/2"
- Net Weight: 6.8 lbs.

1 Year Limited Warranty

1909-0017 | 1918-0097

Carbon Brush SET



GA7020 7" Angle Grinder



- Sanding Disc 7"
- No Load RPM 8,500
- 120 Volts, 15 Amps
- Spindle Thread: 5/8"-11
- Overall Length: 18-5/8"
- Net Weight: 12.2 lbs.

1 Year Limited Warranty

1909-0155 | 1918-0127

Carbon Brush SET

ALPHA Scratch Removal Kit



1910-0045

Designed with stone fabricators in mind, this kit comes with everything you need for scratch removal and seam polishing in the field. Great for Seam Polishing and Removing Scratches! Instructional DVD included.

- Includes:**
 Set of 3" Turboshine Rigid, Turboshine Adapter, VSP-320 Wet Polisher, and Alpha Apron.



FLEX LCP 1703 VR Planetary Polisher



1 Year Limited Warranty

3905-0031

Driver Speed: 1,100-3,400 RPM Tool Weight: 29lbs
 Platen Speed: 600-1,930 RPM Motor: 110V/60Hz,
 Platform Speed: 157-481 RPM 10Amps, GCFI Protected

- The perfect machine for the perfect finish on Concrete, Granite & Marble.
- Rugged, reliable hand-operated 12" platform made of Duralimin, a hardened, anodized aluminum.
- Center water feed for wet applications can be shut off for efficient dry operation.
- Uses 3" and 5" diamond polishing pads.



Dust Shroud

3905-0033



Mudslinger Diamond Polishing Pads

The Mudslinger Pads are 8mm thick, can be run wet or dry. Tests show 4 to 5 times longer life than other leading polishing pads on the market today.

- **Much easier to stay flat**
- **Q.R.S backing**
- **Very high quality**
- **High power polisher needed**

Use under 4,000 RPM - Wet Only

| Grit | 5" | 7" |
|------|-----------|-----------|
| 50 | 4106-1009 | 4106-1037 |
| 100 | 4106-1010 | 4106-1038 |
| 200 | 4106-1011 | 4106-1039 |
| 400 | 4106-1012 | 4106-1040 |
| 800 | 4106-1013 | 4106-1041 |
| 1500 | 4106-1014 | 4106-1042 |
| 3000 | 4106-1015 | 4106-1043 |

Brazed Hard Diamond Discs

These diamond pads are the best for fast stock removal. They are rigid and the edges are tapered for flat polishing and lippage removal.

Q.R.S backing

| Grit | 5" |
|------|-----------|
| #30 | 1806-0028 |
| #60 | 1806-0371 |
| #120 | 1806-0248 |
| #220 | 1806-0370 |

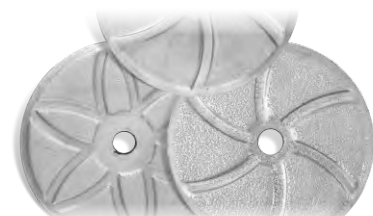



| | | | | | |
|---|---|-----------|----|--|-----------|
| 1 | 1/2" Shaft to 5/8-11 Male Thread | 4308-0084 | 7 | 1/2 Gas Male Thread to Hole for 3/8" Shaft** | 4308-0099 |
| 2 | 3/8" Shaft to 5/8-11 (M) | 4308-0122 | 8 | 1/2 Gas Male to Hole For 1/2" Shaft | 4308-0101 |
| 3 | 5/8-11 Fem. to 5/8-11 Male Ext. W/Waterfeed | 4308-0115 | 9 | 1/2" Shaft to Ghines Female (M10X1.5) | 4308-0085 |
| 4 | 5/8-11 Female to Ghines Female (M10X1.5) | 4308-0087 | 10 | 1/2 Gas Male to Ghines Female (M10X1.5) | 4308-0097 |
| 5 | 1/2 Gas Male to 5/8-11 Male Router | 4308-0095 | 11 | 5/8-18 Male Machine to 5/8-11 Male Thread | 4308-0093 |
| 6 | 1/2 Gas Male to Hole For 1/4" Shaft | 4308-0100 | 12 | 5/8 x 18 Male to 1/2 Gas Female | 4308-0083 |

Call or Check out our website www.granitecitytool.com for our full line of adapters!

Flush Mount Adapters



Flush adapters make the back side of the blade flush allowing difficult flush cuts. The 4-hole adapter is for 4" - 7" blades. The 8-hole adapter is for 8" - 14" blades.

| Desc. | Item # |
|--------------|-----------|
| 8-Hole Alum. | 0501-0055 |
| 4-Hole Steel | 0501-0045 |
| 4-Hole Brass | 0501-0021 |

Not for all blades.

ALPHA Quad Drive Adapters



Works on Alpha Blades.

| Desc. | Item # |
|--------------|-----------|
| 4-Hole Brass | 0501-0001 |



5/8"-11 Flange Adapters

These adapters are used to hold blades with 7/8" openings to prevent them from riding on the threads of the grinder.

| Desc. | Item # |
|------------|-------------|
| Nut Clamp | 99-765-0027 |
| Nut Flange | 99-765-0026 |

7/8" to 5/8"-11 Arbor Adaptor



| Item # |
|-----------|
| 4308-0027 |

| Description | Item # |
|---|-----------|
| 1/2" shaft to 5/8-11 with 1/4" hose conn. | 1918-0083 |
| 1/2" shaft to 5/8-11 with 1/2" hose conn. | 1918-0084 |
| 1/2" shaft to 5/8-11 with garden hose conn. | 1918-0085 |
| 5/8-11 fem. to 5/8-11 male with 1/4" hose conn. | 1918-0086 |
| 5/8-11 fem. to 5/8-11 male with 1/2" hose conn. | 1918-0087 |
| 5/8-11 fem. to 5/8-11 male with garden hose conn. | 1918-0088 |
| 1/2" shaft to 1/2 gas with 1/4" hose conn. | 1918-0089 |
| 1/2" shaft to 1/2 gas with 1/2" hose conn. | 1918-0090 |
| 1/2" shaft to 1/2 gas with garden hose conn. | 1918-0091 |

Water Jackets for Center Water Feed Tools



Use wet only

Made in U.S.A.

DIAMONDWRIGHT®

Flexible Water Hose Assembly with Fittings



1918-0094

10'-1/4" hose with quick-change connector (to fit Flex and Makita waterfeed grinders) on one end and standard female hose connector on other end.



Garden Hose Fittings

Male Adapters

| | |
|------|-----------|
| 3/8" | 2707-0130 |
| 1/2" | 2707-0132 |



Water Couplers

FEMALE PLUG 1/4" Water Hose

1918-0095



Quick Connect Water Hose Adapter 3/8"

99-765-0095

GFCI Cord



1918-0102

Have in-line mechanical G.F.C.I. centrally placed along the cord, test and reset buttons.

Waterfeed Attachments



| | |
|--|-----------|
| Waterfeed Attachment for Grinders/Saws | 1918-0022 |
|--|-----------|



OMEGA™: Graphics Design & Production Software



Gerber OMEGA design and output software is a complete suite of layout, design, output and conversion tools created specifically for use to create professional graphics such as signs, labels and decals, display graphics, and much more.

OMEGA design and output tools are fine-tuned to accommodate stencil and vinyl cutting and printing on sign-industry production devices as well as routers and flatbed cutters.

- Microsoft Windows 7® Professional 32 or 64 bit*, Windows 8 Professional 32 or 64 bit*, & Windows 10 Professional 32 or 64 bit* (*32 or 64 bit, but call for more info.).

Call Us to Upgrade your current Omega software to the latest Omega version to keep up with the latest graphic technology.

OMEGA™ LS (Layout Station)

Economical solution to add a layout (or design) station to your business to help create and design a monument for customer approval. Includes all the design programs of Gerber OMEGA (Composer, File Converter, Font Designer, Font View, Font Manager, GAFMAN, etc.) without any output programs such as GSPPlot and GQManage.

Creative-Premier Designs Monument Package



Package includes software for 3 full books - 400+ designs, 450 Elements to create full designs, 125 special monument shapes, selected clip art, and 10 monument fonts. Three books in print and a CPD clipart catalog also included.

2903-0200

DesignArt



Monumental Software

- Powerful, professional graphic software compatible with Windows 7 and 8.
- Basic monument fonts, shapes, and texture features.
- Great for cemetery lettering and monument shops that want inexpensive software they can expand.

2903-0191



Gerber GSplus™ Plotters

A stepper motor-driven, sprocket plotter that uses perforated materials, the GSplus™ series provides optimal cutting of text and graphics on all Gerber Materials and many others, especially sandblast material.



GS750 2903-0021

For 30" Plotters

Bail Wheel 2903-0002

Bail Wheel Axle 2903-0003

Provide positive tracking for unattended operation and reliable registration or unlimited length cutting. This is a recommended plotter for shops that cut mostly sandblast stencil. Includes an accessory kit, tangential knife tool holder and blade, pen, pounce wheel, and material roll holder.



GS15 2903-0140

| | GS15 ^{plus} | GS750 ^{plus} |
|--------------------|----------------------------------|----------------------------------|
| Configuration | Desktop | Stand |
| Material Feed | Sprocket | |
| Material Width | All 15" Gerber sprocket material | All 30" Gerber sprocket material |
| Cutting Width | 13.25" | 27.25" |
| Cutting Speed | 4" per sec. | 3" per sec |
| Knife Config. | Tangential or Swivel Knife | |
| Cutting Depth Adj. | Dial Control | |
| Pen-Plot & Pounce | Included | |
| Dimensions | 26" x 9" | 47" x 19" |
| Weight | 40.5 lbs | 133 lbs |
| Communication | Serial | |
| Power Req. | 120-240V 47/63Hz | |

GS15 Applications:

Cutting GERBER EDGE Output, Text-Intensive Signs, Precision-Cut Intricate Graphics, Highly Repetitive Work, Time-Sensitive Short-Run Graphics, Long Signs, "Difficult-to-Cut" Materials, Color Output, Fleet Graphics

Plotter Ball Point Pen

Plotter ball point pen black medium 3"
Plotter ball point pen black 1.75"



| | |
|---------|-----------|
| MED. 3" | 2903-0004 |
| 1.75" | 2903-0006 |

Gerber Plotter Knife Blade for Stencil



| Angle | Type | Item # |
|-------|---------|-----------|
| 30° | Carbide | 2903-0048 |
| 45° | Carbide | 2903-0008 |
| 60° | Carbide | 2903-0009 |
| 60° | Generic | 2903-0007 |

Gerber Knife Blades. Solid carbide **SUPER SHARP**. Design for longest life.

60° Holder 99-309-0006

Washer / Theta Knife Lift

2903-0001

REFINISH YOUR PLOTTER DRUM TODAY!

Allen Datagraph I-536 Plotter

| | |
|------------------------|--|
| Maximum Frame Size | Media width less 1 inch (2.5cm) x 150 feet |
| Cutting Technology | Swivel knife; Tangential Emulation |
| Memory Buffer | 2 MB |
| Programmable Cut Speed | Selectable in 100 Steps |
| Acceleration | Selectable, 0.25 to 1G |
| Cutting Force | Selectable, 5.5 to 550 grams. Adjustable in increments of 100 steps |
| Knife Blades | 45 Degree or 60 Degree |
| Pens | Roller Ball: Fiber Tip (HP Style) |
| Command Set | HPGL, HPGL/2 |
| Interfaces | High-Speed USB/Ethernet |
| Media Types/Processed | Vinyl, screen print film, reflective, stencil, mask, magnetic, window tint, capton, etc. |
| Deluxe Stand | Steel construction; Media roll holder; Media catch baskets; casters. |
| Remote Panel | System set-up, control & diagnostics |
| Operating Temperature | 32 to 117 F 0 to 40 C |
| Operating Humidity | Relative, 5% to 95% |
| Physical Dimensions | 36" Cutter 55" x 17" x 13" (140x43x33cm) |
| Weight | 36" Cutter 65lbs, (29.3 kg) |
| Media Width | 36" Cutter 2.5 to 36 inches (6 to 91cm) |



2911-0005

The Model 536 has both Sprocket and Friction Drives! It's Sprocket material-handling system is the preferred cutting solution for processing sandblast stencil material. Plus, it provides a friction material handling system to streamline the cutting of all other media types such as, vinyl, reflective, screen films, paper and more! The iTech 536 GTS comes with a two year limited-liability warranty.

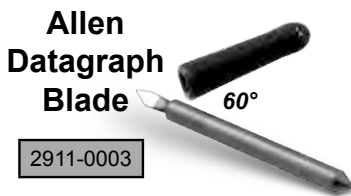

2911-0003



2911-0004

Film Stripping Tool

Used for picking letters out of stencil.



99-309-0035

12 Extra Points

2901-0106



Flatbed Stencil Cutter 827 & ANAfeed Flatbed Stencil Cutter

Works with any stencil - saves money by using non-punched stencil and scrap pieces. Stencil is held in place by vacuum.



Flatbed Plotter

2903-0188

Developed for Monument Makers to give reliability, cutting quality and Cost Savings!

Blades

| | |
|-----|-------------|
| 45° | 99-008-0009 |
| 60° | 99-008-0004 |

Black Pen

2911-0023



Flatbed Plotter with Automatic Feed

2911-0022

BENEFITS OF FLATBED DESIGN:

- Stop paying extra to have perforations punched into your Stencils
- Cut the full Width of your material
- Cut scrap pieces for dates and small Stencils
- Nest Monuments for better Stencil use
- No sprockets to get out of adjustment
- No thick and thin lines
- Material is vacuumed down and not moving
- Accurate Cutting of the smallest details
- Can run on all monument software
- Convenient tool holder
- Round knife cut off for Stencil

| | |
|---|--|
| Plotters | Cutting Speed: 33 .5 in/sec |
| Cutting Area: 30.78"x60" | Maximum material width: 33" |
| Power Input: amp@115vac amp@230 | Warranty: 1 year limited extended warranty available |
| Configuration: Closed loop digital Servo system | Software Language Driver: compatible with all graphics software using HPGL format Custom sizes available |

Sprocket Model 1062 C 25" & 30"

The 1062 sprocket-feed plotter is the ultimate in sprocket-feed technology. Delivering outstanding material cutting performance, positive material tracking with unattended operation, and an incredibly simple loading system.



2903-0189

FEATURES

- Tangential/ Swivel Knife
- Accurate Unattended Operation
- Precision Spocket-Feed Material Drive
- Positive Tracking and Easy Loading
- Simple Key Pad and Easy To Read Display
- Open Architecture Compatible With All Graphics Software Using HPGL Format
- Rugged Industrial-Strength Design**

Material Width: Adjustable 25" or 30"
 Motors: Servo
 Power: 2.5 AMP 120VAC or 1.25 AMP 220VAC
 Speed: 25" Per Second

Model 518-24 24" Portable Plotter



2903-0190

Model 518-24 24" Portable Plotter works off of 12 volts DC or 110V ac. Plug into cigarette lighter or connect to vehicle battery for working on site, out in the field. The unit can also power a laptop computer using one of the two 110 volt outlets.

Cuts up to 24 inch material. Designed for cutting rubber sandblast stencil as well as vinyl and many other materials.

Includes Cigarette adapter, AC power cord, and communication cable.

Compatible design software:

Gerber Omega, Gerber Composer, Graphix Advantage, Coral Draw, Monu-Cad, SignLab, FlexiSign, CadLink and more.

Designed for cutting rubber sandblast stencil
 Plug into cigarette lighter, car battery or 110v AC
 Cut for last dates in the field

Save on stencil....use leftovers. Holds 15" material down to as small as 4" pieces.

High quality, accurate cutting. Saves time when weeding.

Made in the USA!

Allen Datagraph LE Series Laser

Created to meet the image production needs of the Monument, Signmaking and Graphic Arts industries.

Allen Datagraph's LE SERIES LASER in an innovative large format laser automation system for imaging hard surface materials: Granite, Marble, Glass, Mirrors, Acrylics, Brass, Anodized Metals, Wood, Solid-Surface materials and more.

Easily convert image files into stunning laser-etched graphics. System will operate in either raster scan mode for imaging or vector mode for cutting applications. Allen's exclusive image/cut optimization algorithm reduces production time by up to 25% through management of the laser head travel and firing to only the required image/cut areas only.



Roller Stencil Press

Portable Roller Press

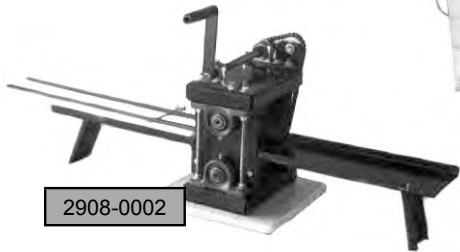

2908-0002

Ideal for remote layout work or cemetery lettering. The 6" x 24" letter tray has enough room for most family names and inscriptions. Can be easily and quickly knocked down for storage or transport. In stock, and light enough for UPS shipment.



6" Hand Crank Single Roller



12" Hand Crank Single Roller

2904-0023

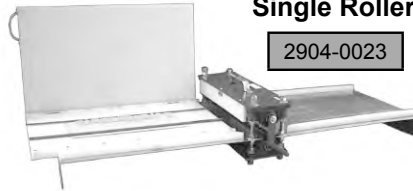

These stencil cutting machines operate on the basis of a tray being pressed as it rolls forward then reversed between rollers. The rollers are preset to the thousandths of an inch for proper pressing. Machines have been designed to be used with plastic die-cutting letters, numerals, and designs as they are uniform in thickness. These hand crank models are easily used in the shop or on-site as they are small and lightweight.

Adjustable Letter Racks

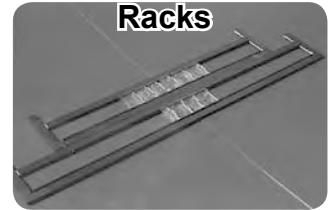

Specifically designed for roller and bridge press machines. Instant adjustment to any letter size from 3/4" to 3-1/2" makes these racks indispensable for straight lines and better layouts.

| | | | |
|-----|-----------|-----|-----------|
| 18" | 2904-0010 | 30" | 2904-0012 |
| 24" | 2904-0011 | 36" | 2904-0013 |

Blue Duct Tape

Pulls Clean! No Residue!

Heavy duty high tack tape designed for quick cover up and patching out of range of the direct blast. Super heavy backing for best blast resistance.



| | |
|-------------|-----------|
| 2" x 60 yd. | 5506-0030 |
| 3" x 60 yd. | 5506-0031 |
| 4" x 60 yd. | 5506-0032 |
| 6" x 60 yd. | 5506-0033 |

Filler Tape

Double coated adhesive tape attaches to stencil then to the stone. No filler needed. Tape and adhesive peel off with stencil after blasting.



| | |
|--------------|-----------|
| 2" x 60 yd. | 5506-0009 |
| 3" x 60 yd. | 5506-0011 |
| 4" x 60 yd. | 5506-0013 |
| 6" x 60 yd. | 5506-0014 |
| 8" x 60 yd. | 5506-0016 |
| 12" x 60 yd. | 5506-0018 |

3M Painters Tape

This tape removes cleanly without adhesive transfer or surface damage for up to 14 days, even in direct sunlight.



| | |
|---------------|-----------|
| 24mm x 60 yd. | 5209-0031 |
| 48mm x 60 yd. | 5209-0032 |

Green Masking Tape

3M Green Masking Tape. Highly conformable, provides the best adhesive transfer resistance, hugs curves, contours and provides outstanding paint lines. Goes on quickly and easily, sticks at a touch and stays put. Perfectly balanced to give outstanding masking results.



| | |
|------|-----------|
| 3.7" | 5506-0007 |
|------|-----------|

Transfer Tape

A semi-bleached flat back release coated poly, coated with a medium adhesion rubber based adhesive.



| | |
|----|-----------|
| 2" | 5506-0037 |
| 6" | 5506-0024 |

Counter Top Protection

- Great for most hard surfaces such as corian, surell (Formica), granite, silestone, avonite, ceramic tile, etc.
- Protects tile grout from staining
- Scratch-resistant



Clear 0712-0014

24" x 600' Coverage sq. ft. 1,200

3M Sandblast Filler

Use **No. 2** with hand cut types of stencil and for patching. Maximum holding power. Use **No. 3** with the machine cut (Mylar) stencil to lessen tearing and to provide easier release of the Mylar from the panel during clean up.



| Item | Size | Item# |
|-------|--------|-----------|
| No. 2 | Quart | 5503-0001 |
| No. 2 | Gallon | 5503-0004 |
| No. 3 | Gallon | 5503-0005 |

GCT Filler Remover

The highest quality biodegradable 100% citrus product for removing filler residue from panels quick and easy. Eliminates solvent or gas pollution problems. Simply spray or brush surface with product, allow to stand for a few minutes, then rinse thoroughly with water. Cost effective and environmentally safe.



| Size | Item# |
|----------|-----------|
| Gallon | 5504-0018 |
| 5 Gallon | 5504-0019 |

Anchor Sandblast Filler

#211 Solvent based high tack filler specifically designed to be used with single back hand cut stencil of patching.

#223 Solvent based regular tack filler specifically designed to be used with double back mylar stencil.



| Item | Size | Item# |
|------|--------|-----------|
| #211 | Gallon | 5503-0002 |
| #223 | Gallon | 5503-0003 |

3M Adhesives

For quick applications, dries faster than brush-on filler. Use on unusual materials and irregular surfaces.

No. 77 Aerosol Adhesive: Low mist spray adhesive improves bonding strength to mostly any surface. For extra strength, spray both surfaces.



| Type | Item # |
|------|-----------|
| #77 | 0304-0006 |

Plotter Drawing Paper



Available in 30" and 15" widths with IBM or Gerber punch or with a plain edge for Friction Feed units. Standard 20 lbs. paper weight. Vellum also available.

| Size | Gerber Punch | IBM Punch |
|------------|--------------|-----------|
| 15" x 500' | 2902-0002 | - |
| 30" x 300' | 2902-0003 | 2902-0005 |

White Rubber Mallet



Mallet is non marking. Rubber head securely mounted on wood handle.

2305-0081

Vaper Spot Spray Pneumatic Spray Gun

- 32oz - Refillable
- Not for use with paint products
- Eco friendly
- 80-150 PSI operating pressure
- Refillable
- Do not use with flammable propellants
- Eliminates dangerous or harmful propellants
- Eco-friendly



5504-0021

Jar and Brushes

Metal and Plastic jars with good quality brushes make a good combination for handling stencil filler in the shop or field.

Metal

| Qt. | 2" Brush | Item# |
|-----|----------|-----------|
| | | 5501-0006 |

Plastic

| Qt. | Jar/Brush | Item# |
|-----|-----------------|-----------|
| | | 5501-0005 |
| | Removable Brush | 5501-0004 |
| | Rubber Grommet | 5501-0002 |



3M™ - Scotch Computer Stencil

3M™ Sandblast Stencil 519YP2T

47.0 mil (1.2 mm) tan rubber backing with clear film laminate, rubber adhesive and 2mm thick translucent white film liner. Computer-Cut, Tractor Feed - Double Liner Format. 1/2" on center punch.

| Size | Item# | |
|-------------|---------------|---|
| 25" x 10 yd | 5505-51925007 | T |
| 25" x 20 yd | 5505-51925207 | T |
| 30" x 10 yd | 5505-51930007 | T |
| 30" x 20 yd | 5505-51930207 | T |

3M™ Sandblast Stencil 519YT

45.0 mil (1.1 mm) tan rubber backing with clear film laminate, rubber adhesive and easy-release translucent white film liner. Computer-Cut, Tractor Feed - Double Liner Format. 1/2" on center punch.

| Size | Item# | |
|-----------------|---------------|---|
| 15" x 10 yd | 5505-51915004 | T |
| 18-3/4" x 10 yd | 5505-51918004 | T |
| 25" x 10 yd | 5505-51925004 | T |
| 25" x 20 yd | 5505-51925201 | T |
| 30" x 10 yd | 5505-51930004 | T |
| 30" x 20 yd | 5505-51930205 | T |

3M™ Sandblast Stencil 519YS

45.0 mil (1.1 mm) tan rubber backing with clear film laminate, rubber adhesive and easy-release translucent white film liner. Computer-Cut, Slot Punched - Double Liner Format.

| Size | Item# | |
|-------------|---------------|---|
| 15" x 10 yd | 5505-51915005 | S |
| 30" x 10 yd | 5505-51930005 | S |
| 30" x 20 yd | 5505-51930205 | S |

3M™ Sandblast Stencil 520T

45.0 mil (1.1 mm) tan rubber backing with gray rubber adhesive and easy-release clear film liner. Computer-Cut, Tractor Feed - Single Liner Format. 1/2" on center punch.

| Size | Item# | |
|-------------|---------------|---|
| 15" x 10 yd | 5505-52015002 | T |
| 25" x 10 yd | 5505-52025002 | T |
| 30" x 10 yd | 5505-52030002 | T |

3M™ Sandblast Stencil 520S

45.0 mil (1.1 mm) tan rubber backing with gray rubber adhesive and easy-release clear film liner. Computer-Cut, Slot Punched - Single Liner Format.

| Size | Item# | |
|-------------|---------------|---|
| 15" x 10 yd | 5505-52015001 | S |
| 30" x 10 yd | 5505-52030001 | S |
| 30" x 20 yd | 5505-52030201 | S |

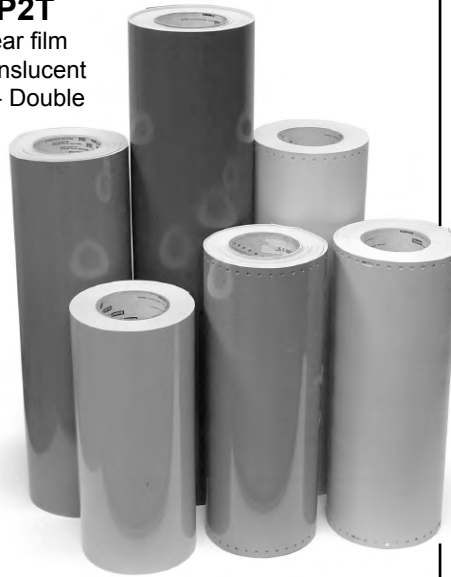

3M™ Sandblast Stencil 1532S

37.0 mil (.9 mm) green rubber backing with rubber adhesive and dark green polyethylene film high release liner. Computer-Cut, Slot Punched - Single Liner Format.

| Size | Item# | |
|-------------|---------------|---|
| 30" x 10 yd | 5505-15323000 | S |

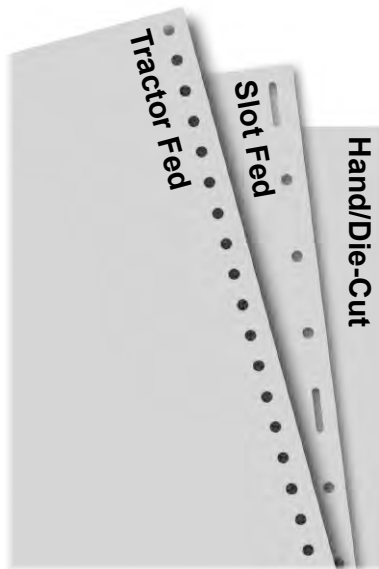

3M™ Stencil

3M™ Sandblast Stencil 507

43.0 mil (1 mm) green rubber backing with rubber adhesive and dark green polyethylene film high release liner. Ideal for letter press operations. Hand-Cut - Single Liner Format.

| Size | Item# | |
|-----------------|---------------|----|
| 12-1/4" x 10 yd | 5505-50712000 | FH |
| 24-1/2" x 10 yd | 5505-50724000 | T |

3M™ Sandblast Stencil 510

42.0 mil (1 mm) green rubber backing with rubber adhesive and easy-release clear film liner. Hand-Cut - Single Liner Format.

| Size | Item# | |
|-----------------|---------------|---|
| 12-3/4" x 10 yd | 5505-51012000 | H |
| 18-3/4" x 10 yd | 5505-51018000 | H |
| 25" x 10 yd | 5505-51025000 | H |
| 30" x 10 yd | 5505-51030000 | H |

3M™ Sandblast Stencil 519Y

45.0 mil (1.1 mm) tan rubber backing with clear film laminate, rubber adhesive and easy-release translucent white liner. Die-Cut - Doubled Liner Format.

| Size | Item# | |
|-----------------|---------------|-----|
| 12-3/4" x 10 yd | 5505-51912013 | FHM |
| 15" x 10 yd | 5505-51915003 | FHM |
| 18-3/4" x 10 yd | 5505-51918003 | FHM |
| 21" x 10 yd | 5505-51921003 | FHM |
| 25" x 10" | 5505-51925003 | FHM |
| 30" x 10 yd | 5505-51930003 | FHM |

3M™ Sandblast Stencil 520

45.0 mil (1.1 mm) tan rubber backing with gray rubber adhesive with easy-release clear film liner. Hand and Die-Cut - Single Liner Format.

| Size | Item# | |
|-----------------|---------------|----|
| 15" x 10 yd | 5505-52015000 | FH |
| 18-3/4" x 10 yd | 5505-52018000 | FH |
| 25" x 10 yd | 5505-52025000 | FH |
| 30" x 10 yd | 5505-52030000 | FH |

Legend:

| | | | |
|-----|------------------------------|---|--------------|
| Y | Yellow inner liner | H | Hand Cut |
| T | IBM computer hole plotter | F | Friction Fed |
| S | Gerber computer hole plotter | M | Machine |
| P | Polyester | | |
| YP2 | All rubber is rolled out | | |

U-Blast Computer Stencil

| STENCIL CROSS REFERENCE CHART | | |
|-------------------------------|---------|----------|
| U-Blast | 3M | ANCHOR |
| 619 Y | 519 Y | 123 |
| 619 YT | 519 YT | 154. 129 |
| 619 YPT | 519 YPT | |
| 619 YS | 519 YS | 124 |
| 619 YPS | 519 YPS | |
| 620 T | 520 T | 157. 158 |
| 620 S | 520 S | 117 |
| 620 | 520 | 111. 112 |
| 621 S | | 116 S |
| 621 T | | 116 T |

- Picks and weeds cleanly and quickly
- Easy to see lines after cutting
- Cutting is a piece of cake
- Consistent, excellent adhesion
- Fast and easy clean-up
- **Cost much less than other brands!**

FREE FREIGHT

ON ORDERS OVER \$3,000 -CONTINENTAL USA-

Common Stock



620T Sandblast Stencil

Single Liner stencil with IBM computer holes. (Medium-tack)

| Size | Item# | |
|--------------------|---------------|---|
| 15" x 10 Yards | 5510-62015002 | T |
| 18 3/4" x 10 Yards | 5510-62018002 | T |
| 25" x 10 Yards | 5510-62025002 | T |
| 30" x 10 Yards | 5510-62030002 | T |

620S Sandblast Stencil

Single Liner stencil with Gerber computer holes. (Medium-tack)

| Size | Item# | |
|----------------|---------------|---|
| 15" x 10 Yards | 5510-62015001 | S |
| 30" x 10 Yards | 5510-62030001 | S |

620 Sandblast Stencil

Single Liner stencil without computer holes. (Hand- cut)

| Size | Item# | |
|--------------------|---------------|----|
| 12 3/4" x 10 Yards | 5510-62012000 | FH |
| 15" x 10 Yards | 5510-62015000 | FH |
| 18 3/4" x 10 Yards | 5510-62018000 | FH |
| 21" x 10 Yards | 5510-62021000 | FH |
| 25" x 10 Yards | 5510-62025000 | FH |
| 30" x 10 Yards | 5510-62030000 | FH |

621S Sandblast Stencil

Single Liner stencil with Gerber computer holes. (High- tack)

| Size | Item# | |
|----------------|---------------|---|
| 15" x 10 Yards | 5510-62115001 | S |
| 30" x 10 Yards | 5510-62130001 | S |

619Y Sandblast Stencil

Double Liner stencil with no computer holes

| Size | Item# | |
|--------------------|---------------|----|
| 12 3/4" x 10 Yards | 5510-61912003 | FH |
| 15" x 10 Yards | 5510-61915003 | FH |
| 18 3/4" x 10 Yards | 5510-61918003 | FH |
| 21" x 10 Yards | 5510-61921003 | FH |
| 25" x 10 Yards | 5510-61925003 | FH |
| 30" x 10 Yards | 5510-61930003 | FH |

619YPT Sandblast Stencil

Double Liner stencil with Yellow Backing and IBM computer holes.

| Size | Item# | |
|--------------------|---------------|---|
| 15" x 10 Yards | 5510-61915004 | T |
| 25" x 10 Yards | 5510-61925004 | T |
| 25" x 20 Yards | 5510-61925204 | T |
| 27 1/2" x 10 Yards | 5510-61927004 | T |
| 30" x 10 Yards | 5510-61930004 | T |
| 30" x 20 Yards | 5510-61930204 | T |
| 32 1/2" x 10 Yards | 5510-61932004 | T |

619YPS Sandblast Stencil

Double Liner stencil with Yellow Backing and Gerber computer holes.

| Size | Item# | |
|----------------|---------------|---|
| 15" x 10 Yards | 5510-61915005 | S |
| 30" x 10 Yards | 5510-61930005 | S |
| 30" x 20 Yards | 5510-61930205 | S |

Legend:

| | |
|-----|------------------------------|
| Y | Yellow inner liner |
| T | IBM computer hole plotter |
| S | Gerber computer hole plotter |
| P | Polyester |
| YP2 | All rubber is rolled out |
| H | Hand Cut |
| F | Friction Fed |
| M | Machine |



Patch Stencil
30" Rolls

5510-66000000

Anchor Continental Computer Stencil

#116 (.8 mm) single back stencil. High tack adhesive formulated to adhere to raw wood and rough surfaces without using filler. For Gerber plotters.

| Size | Item# | |
|------|---------------|-----|
| 15" | 5502-11615000 | TFS |
| 30" | 5502-11630000 | FS |

#117 (.8 mm) single back stencil. Suitable for use on monuments, wood or glass. For Gerber plotters.

| Size | Item# | |
|------|---------------|-----|
| 15" | 5502-11715000 | TFS |
| 30" | 5502-11730000 | FS |

#124 (1.2 mm) double back mylar stencil. Designed for cutting on Gerber plotters.

| Size | Regular | Yell. | |
|------|---------------|-------|---|
| 15" | 5502-12415000 | - | S |
| 30" | 5502-12430000 | 30004 | S |

#129 (1.1 mm) yellow mylar stencil that has a thick mylar liner for sprocket holes. 15" suitable for use on Gerber and IBM style sprockets. 30" suitable for IBM sprocket only.

| Size | Yellow | |
|------|---------------|----|
| 15" | 5502-12915004 | SF |
| 25" | 5502-12925004 | TF |
| 30" | 5502-12930004 | TF |

#153 (.8 mm) single back stencil. This unpunched product is designed for the Roland friction feed plotter.

| Size | Item# | |
|---------|---------------|---|
| 19-7/8" | 5502-15319000 | F |
| 24" | 5502-15324000 | F |

#154 (1.2mm) double back mylar stencil. Features the same construction as #123 machine stencil. Designed to be used with IBM sprocket plotters only.

| Size | Item# | Yell. | |
|---------|---------------|-------|---|
| 15" | 5502-15415000 | - | T |
| 18-3/4" | 5502-15418000 | - | T |
| 25" | 5502-15425000 | 25004 | T |
| 30" | 5502-15430000 | 30004 | T |

#155 (.8 mm) Same construction as our #153 stencil, except this product has a water-based acrylic adhesive, rather than petroleum based.

| Size | Item# | |
|---------|---------------|---|
| 19-7/8" | 5502-15519000 | F |
| 24" | 5502-15524000 | F |

#156 (.8 mm) Same construction as our high-tack #116 computer stencil, except that the hole pattern is for use on standard 1/2" center machines

| Size | Item# | |
|------|---------------|----|
| 30" | 5502-15630000 | TF |

#157 (.8 mm) single back stencil. Same construction as #111 regular stencil. Designed to be used with IBM sprocket plotters only.

| Size | Item# | |
|------|---------------|----|
| 30" | 5502-15730000 | TF |

#192 (1.1 mm) yellow mylar stencil with Gerber punch. Same as the #124 except features a thicker clear liner.

| Size | Item# | |
|------|---------------|---|
| 10" | 5502-19230004 | S |
| 30" | 5502-19230004 | S |



Stencil Products
ANCHOR
An Interstage Polymer Group™ Brand

Legend:

| | | | |
|-----|------------------------------|---|--------------|
| Y | Yellow inner liner | H | Hand Cut |
| T | IBM computer hole plotter | F | Friction Fed |
| S | Gerber computer hole plotter | M | Machine |
| P | Polyester | | |
| YP2 | All rubber is rolled out | | |

#111 (1.1 mm) easy release. Single back stencil designed for hand cutting. Superior for shape carving and easy cutting.

| Size | Item# | |
|---------|---------------|---|
| 12-3/4" | 5502-11112000 | H |
| 18-3/4" | 5502-11118000 | H |
| 21" | 5502-11121000 | H |
| 25" | 5502-11125000 | H |
| 30-1/2" | 5502-11130000 | H |

#123 (1.2 mm) double back mylar stencil designed for machine cutting. Excellent blast resistance.

| Size | Item# | Yell. | |
|---------|---------------|-------|---|
| 12-3/4" | 5502-12312000 | - | M |
| 15" | 5502-12315000 | - | M |
| 18-3/4" | 5502-12318000 | - | M |
| 25" | 5502-12325000 | 25004 | M |
| 30" | 5502-12330000 | 30004 | M |

#120 (.8 mm) Wood/Glass stencil. 75% as thick as the standard single back. Offers greater detail and deeper blasting capabilities.

| Size | Item# | |
|------|---------------|---|
| 25" | 5502-12025000 | H |

#125 (.9 mm) Signblast stencil. High tack adhesive formulated to adhere to raw wood and rough surfaces without using filler.

| Size | Item# | |
|------|---------------|---|
| 25" | 5502-12525000 | H |

#128 (.7 mm) Glass stencil. Half the thickness of standard single back stencil. Designed for frosting glass.

| Size | Item# | |
|------|---------------|---|
| 25" | 5502-12825000 | H |

#T226 (.5 mm) High-tack BlastLite™ is a specially-formulated rubber mask that is long-lasting and easy to use. Natural flexibility properties and impact resistance is great for shallow blasting.

| Size | Item# | |
|------|---------------|---|
| 15" | 5502-22615005 | H |
| 20" | 5502-22620005 | H |
| 25" | 5502-22625005 | H |

Classic Roman

Alphabet sizes: 1/2" through 4-1/2"
 Numeral sizes: 1/2" through 2-1/2"

ABCDEFGHIJKLMN
 OPQRSTUVWXYZ
 1234567890

Modified Roman

Alphabet sizes: 3/4" through 4-1/2"
 Numeral sizes: 5/8" through 2-1/2"

ABCDEFGHIJKLMN
 OPQRSTUVWXYZ
 1234567890

Condensed Roman

Alphabet sizes: 3/4" through 4"
 Numeral sizes: 3/4" through 2"

ABCDEFGHIJKLMNO
 PQRSTUVWXYZ&:-
 1234567890--

Special Roman 2

Alphabet sizes: 1-1/4" through 3-1/2"
 Numeral sizes: 1" and 1-1/4"

ABCDEFGHIJK
 KLMNOPQRS
 TUVWXYZ&
 1234567890

Roman Lower Case

Alphabet sizes: 5/8" through 2"
 Numeral sizes: 5/8" through 1-1/4"

abcdefghijklm
 nopqrstuvwxyz
 1234567890 1234567890
Style A Style B

Round Corner Gothic

Alphabet sizes: 3/4" through 2"
 Numeral sizes: 3/4" through 1-3/4"

ABCDEFGHIJKLM
 NOPQRSTUVWXYZ
 1234567890

Splayed Corner Gothic

Alphabet sizes: 5/8" through 4"
 Numeral sizes: 3/4" through 2"

ABCDEFGHIJKLM
 NOPQRSTUVWXYZ
 1234567890--

Panel

Alphabet sizes: 1-1/2" through 4"
 Numeral sizes: 1-1/4" through 2"

ABCDEFGHIJKLMNO
 PQRSTUVWXYZ&:-

Vermarco

Alphabet sizes: 1/2" through 3-1/2"
 Numeral sizes: 1/2" through 1-3/4"

ABCDEFGHIJKLMN
 OPQRSTUVWXYZ
 1234567890

Double Outline Vermarco

Alphabet sizes: 1-1/4" through 3-1/2"
 Numeral sizes: 1-1/4", 1-1/2", & 1-3/4"

ABCDEFGHIJKLMN
 OPQRSTUVWXYZ&:-
 1234567890--

Uncial Gothic

Alphabet sizes: 1-1/4" through 3-1/2"
 Numeral sizes: 1", 1-1/4" & 1-1/2"

ABCDEFGHIJKLMNO
 PQRSTUVWXYZ&:-
 1234567890--

Hebrew

Alphabet sizes: 3/4", 1", 1-1/4" & 1-1/2"

אבגדהוזחטיפכל
 זכטעפפצקרשתת
 יאבגדה

Old English

Alphabet Sizes: Upper Case: 1-1/2", 2-1/4", & 3" Lower Case: 7/8", 1", 1-1/2", & 2"
 Numeral sizes: 1-1/4" & 1-3/4" Note: Use Upper Case 1-1/2" letters with 7/8" or 1"
 Lower Case, 2-1/4" with 1-1/2" and 3" Upper Case with 1-3/4" Lower case for
 uniformity, clarity and beauty. Thus, two alphabets are required in each size.

ABCDEFGHIJK
 IJKLMNOPRS
 TUVWXYZ
 abcdefghijklm
 1234567890



Scriptural Art

Alphabet Sizes: Upper Case: 2-1/4", & 3"
 Lower Case: 1-1/4", & 1-3/4"
 Numeral sizes: 1", 1-1/4" & 1-1/2"

ABCDEFGHIJKLM
 NOPQRSTUVWXYZ
 abcdefghijklmnopqrstuvwxyz
 1234567890

Also Available:
Special Roman 1
Deluxe Roman

Stencil Lettering 2905-

Modified Roman

Small Sizes: 3/4", 1", 1-1/4", 1-1/2", 1-3/4"
Large Sizes: 2", 2-1/4", 2-1/2", 2-3/4", 3", 3-1/2"



Common Gothic

Small Sizes: 3/4", 1", 1-1/4", 1-1/2"
Large Sizes: 2", 2-1/2"

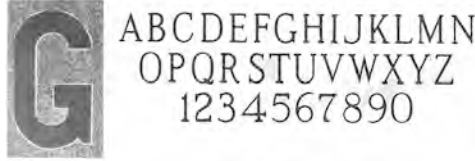

Old English

3/4", 1", 1-1/4", 1-1/2", 2", 3"

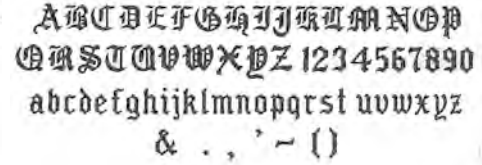

Modified Roman (Raised Letters)

Small Sizes: 3/4", 1", 1-1/4", 1-1/2"
Large Sizes: 1-3/4", 2", 2-1/2", 3", 3-1/2"



Vermarco Double Outline

Small Sizes: 3/4", 1", 1-1/4", 1-1/2"
Large Sizes: 2", 2-1/2"

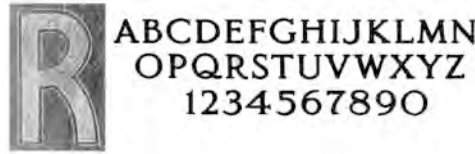

Vermarco

5/8", 3/4", 1", 1-1/4", 1-1/2", 1-3/4", 2", 2-1/2", 3", 3-1/2"



Veteran

Sizes: 1/2", 3/4", 7/8", 1-1/8", 1-1/2"



Shadow Outline

(numerals not included)



Government

1/2", 3/4", 7/8", 1-1/8", 1-1/2" (numerals included)



Condensed Roman

Small Sizes: 3/4", 1", 1-1/4", 1-1/2", 1-3/4"
Large Sizes: 2", 2-1/2", 3", 3-1/2"



Classic Roman

3/4", 1", 1-1/4", 1-1/2"

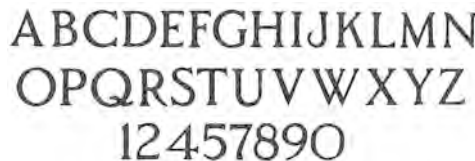

Modified Roman Heavy Bar

Available in: 3/4", 1" & 1-1/4"



Double Outline

Small Sizes: 1", 1-1/4", 1-3/8", 1-1/2", 1-3/4"
Large Sizes: 2", 2-1/2", 3", 3-1/2", 4"



Hebrew

3/4", 1", 1-1/4", 1-1/2"

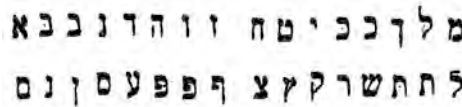

Polished Edge

Small Sizes: 3/4", 1", 1-1/4", 1-1/2"
Large Sizes: 2", 2-1/2", 3"



Modern Roman

3/4", 1", 1-1/4", 1-1/2", 1-3/4", 2", 2-1/2", 3"



These designs plus hundreds of others are available through Granite City Tool. Request a design catalog.

Tracing Paper

This 16 lb. ivory sketch paper is thin, yet tough, and has a high transparency. Available in 12", 36" & 42" widths x 50 yard rolls and 8-1/2" x 11", or 11" x 17" sheets 500 per package.

| Size | Type | Item # |
|---------------------|--------|-----------|
| 11" x 17" | SHEETS | 2909-0007 |
| 8-1/2" x 11" | SHEETS | 2909-0002 |
| 12" x 50 YDS (EH23) | ROLLS | 2909-0001 |
| 36" x 50 YDS | ROLLS | 2909-0004 |
| 42" x 50 YDS | ROLLS | 2909-0006 |

Tracing Vellum

Heavy weight, high transparency material is made of 100% rag. Excellent for full size renderings and design art work.



| | |
|---------------------|-----------|
| 36" x 20 YDS (EH23) | 2909-0005 |
|---------------------|-----------|

GCT Sharper Image Rubbing Paper

Special carbon fiber paper for taking exact impressions of shaped carvings, designs and inscriptions. Easy to use.

| Size | Type | Item # |
|------------|-------|-----------|
| 26" x 100' | White | 2907-0004 |
| 26" x 100' | Blue | 2907-0007 |

Carbon Paper

High grade heavy duty pencil carbon.

| Size | Color | Item # |
|-----------|-------|-----------|
| 13" x 39" | Black | 2910-0002 |
| 12" x 12" | White | 2910-0001 |

Transparent Triangles

Heavy, transparent seasoned celluloid triangles, .085" thickness. "Rubbed" and polished finish. Have finger lifts for easy pick up. Finest quality. 30/60 and 45/90 degrees.

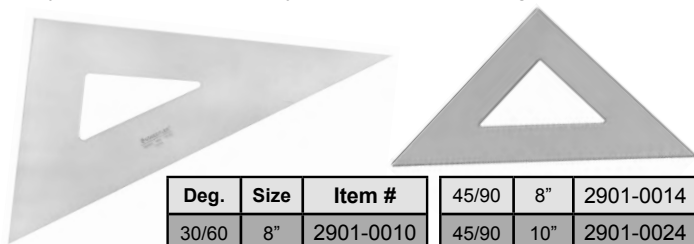

| Deg. | Size | Item # |
|-------|------|-----------|
| 45/90 | 8" | 2901-0014 |
| 45/90 | 10" | 2901-0024 |
| 45/90 | 12" | 2901-0033 |
| 45/90 | 14" | 2901-0047 |
| 30/60 | 8" | 2901-0010 |
| 30/60 | 10" | 2901-0013 |
| 30/60 | 12" | 2901-0023 |
| 30/60 | 14" | 2901-0034 |
| 30/60 | 18" | 2901-0046 |

Rubbing Wax

1/8 lb Block



| |
|-----------|
| 2907-0002 |
|-----------|

Steel Rules

True straight line rules, flexible with deeply etched accurate figures. Useful for layout work. High grade steel.

| Size | Item # |
|------|-----------|
| 36" | 2901-0059 |
| 48" | 2901-0061 |

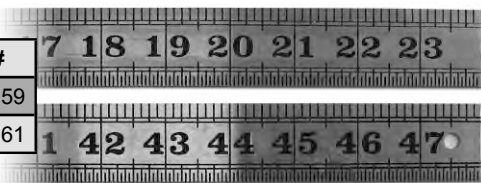

| Size | Item # |
|------|-----------|
| 12" | 2901-0015 |
| 18" | 2901-0029 |
| 24" | 2901-0032 |
| 36" | 2901-0041 |
| 48" | 2901-0050 |

Center Finding Rule

This aluminum center finding rule, with zero center, is a fine instrument for layout use on drawing board or stencil press for balancing inscriptions.

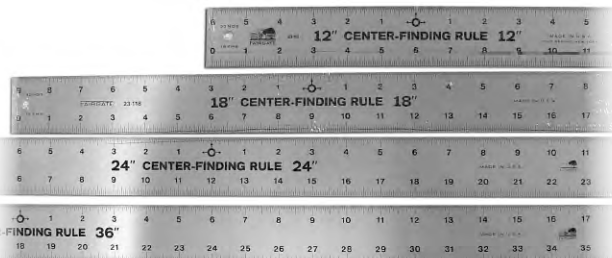

Holes Stencil Knife

This well designed tool for stencil cutting has a polished, aluminum barrel with knurled finger grip for sure control. Includes a 4" surgical steel blade that is pre-sharpened its full length. Extra blades available.



| Type | Item # |
|-------------|-----------|
| Blades | 2901-0003 |
| Knife | 2901-0040 |
| Lance Point | 2901-0004 |
| 12 Blades | 2901-0051 |

Double Bladed Stencil Knife

Parallel cuts are very quick and easy. Rapid adjustment to 1/2 inch at the turn of a screw at the top. Great for borders.



| Type | Item # |
|-------|-----------|
| Blade | 2901-0066 |
| Knife | 2901-0049 |

Hyde Stencil Knife

Knives available in two different styles. No. 2 style is 4-1/2" over all with a wood handle. These blades are made of high quality tungsten hacksaw steel and will fit other knives, too, if right width is selected from scale.



| | | |
|-------|-------------------|-----------|
| No. 2 | #2SR Wood 4 1/2" | 2901-0035 |
| Blade | #1 4 3/4" x 5/16" | 2901-0006 |

Granite City Rollers

The solid steel seam rollers are for ironing out wrinkles in stencil and sealing surfaces.

| | | |
|-------|----|-----------|
| Metal | 2" | 2901-0103 |
| Metal | 4" | 2901-0105 |



Danair AH-15S Air Hammer with Soft Plastic Head

Offers the Manufacturing, Fabricating and Assembly Industry a replacement to cumbersome hammers and mallets. The hammer mechanism starts with light pressure and stops immediately when the auto hammer is lifted from the surface. Also offers interchangeable hammer tips.



1505-0027

Tapestry Carving Screen

Gives cemetery memorials more sales appeal. "Tapestry" background carving is fast, easy and economical. It costs less to produce than a deep sunken background. Simply sandblast through template to texture the background area. Minimum size template is 12" x 12".

2901-0101

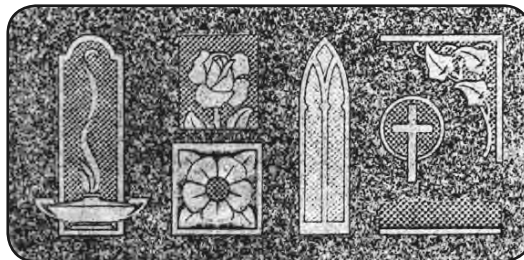

Film Stripping Tool

Used for picking letters out of stencil.

99-309-0035

12 Extra Points

2901-0106



Sight Screen

This fine mesh steel or brass screen fits all original equipment blast curtains. Highly protective, it wears better and offers clear vision. Sold by the linear foot.



| Type | Size | Item # |
|-----------------|---------|-----------|
| Steel | 8" W | 4709-0005 |
| Steel | 10" W | 4709-0003 |
| Steel | 12" W | 4709-0006 |
| Steel | 18" W | 4709-0007 |
| Brass | 12" W | 4709-0001 |
| Stainless Steel | 14-5/8" | 4709-0004 |
| Stainless Steel | 16-1/4" | 4709-0002 |

Popular Sizes

Steel:
8"x49", 8"x72", 10"x49", 10"x72",
12"x49", 12"x72", 12"x78",

Stainless Steel:
14-5/8"x21.5", 14-5/8"x27.5",
16-1/4"x48", 16-1/4"x60"

Marco® PORTABLE SANDBLAST TANKS

Dependable pressure type units to do professional work for cemetery lettering, monument, and hobbyist applications.

Direct pressure offers powerful impact regardless of tank capacity. The single lever control of mixing valve is the most important feature of the sandblast machine. It opens the air port to clear the hose, then accurately adjusts the sand feed to the desired mixture.

| Model | Abrasive Cap. | Kwikfire | PSI | Item # |
|-------|---------------|----------|-----|-----------|
| .35 L | 35 lbs. | No | 150 | 4708-0006 |
| 1.5 L | 150 lbs. | No | 125 | 4708-0043 |
| 1.5 L | 150 lbs. | Yes | 125 | 4708-0059 |
| 3.5 M | 350 lbs. | Yes | 150 | 4708-0061 |
| 6.5 M | 650 lbs. | Yes | 150 | 4708-0060 |



Model 35

Includes: moisture separator, pressure gauge, mixing valve, 10ft of 1/2" I.D. sandblast hose and 2 #1 ceramic nozzles 1/8" opening.



99-695-0257

581 Conversion Kit

ShapeCarve like the pros with the infinitely controllable 581 hand wheel operated mixing valve.



Model 350

KIT Includes: moisture separator, 50ft of 1" I.D. sandblast hose with connections, & 1/4" Blaze Venturi Nozzle.

6001-0479

KIT

Model 150

Includes: moisture separator, pressure gauge, mixing valve, 25ft of 1/2" I.D. sandblast hose and 2 #1 ceramic nozzles 1/8" opening and 2 5/32" opening.



4705-0001

Kwikfire 153

Cast iron Remote Control Switch offers instant on and off control of the abrasive flow at the nozzle.

Blast Control Valve

This in-line valve offers instant stop and start control of the abrasive. Installs in the sandblast hose, between the nozzle and the blast generator, eliminating the need for adjusting or resetting blast controls. Size: 1/2"

4702-0002



Model 650

KIT Includes: moisture separator, 50ft of 1-1/4" I.D. sandblast hose with connections, & 5/16" Blaze Venturi Nozzle.

6001-0480

KIT



EMPIRE SUPERBLAST PORTABLES

SuperBlast portables include a Dry-Float moisture/oil separator, flexible air lines, EZ Fill bag breakers and many other features to increase productivity and profits. In addition, these portables give you an extra one-half cubic-foot capacity and come in stationary models that are suitable for truck mounting or blast rooms.

| Model | Capacity | Pipe String | Item # |
|----------------|-------------|-------------|-----------|
| 350 Stationary | 3.5 cu. ft. | 1" | 4708-0021 |
| 350 Portable | 3.5 cu. ft. | 1" | 4708-0020 |
| 650 Stationary | 6.5 cu. ft. | 1 1/4" | 4708-0022 |

Electric Remote Box

4708-0025

Hose & Holder Kit

6001-0181

EMPIRE MINI BLASTERS

4708-0048

Media Cap. 100lbs
Tank Diam. 12"
Weight: 50lbs.



4708-0047

Media Cap. 300lbs
Tank Diam. 16"
Weight: 102lbs.



ZIG ZAG Abrasive Sifter

4701-0006

Floor unit with top screen for collecting large objects and a bottom zig zag pattern screen for separating coarse from fine abrasive.





Blast Cabinets

Economically priced sandblast cabinets allow users a completely self contained sandblast system. Complete units come with dust collector, foot actuated on/off control, abrasive recycling, suction blast gun and lighted cabinet with protective gloves. Available in various sizes and configurations.

- Economically priced
- Completely self contained
- Illuminated interior
- Dust collector
- Pressure regulator
- Foot pedal on/off
- Long lasting carbide nozzle
- 12 CFM and 25 CFM
- Welded steel cabinet
- Steel screen work table
- Window underlayment
- Attached work gloves
- Door safety switch on most models

**Many sizes and types available,
Call For Details**



ESB 007 Spot Blast

The Econoline ESB 007 Spot Blast unit is a portable, dust free solution to your blasting needs. Low abrasive consumption recycles abrasive media separate from dust and debris. Includes a standard 12 CFM trigger gun, regulator and gauge, water filter, recycling head and a .5 micron cartridge filter. This unit weighs just 55 lbs when empty, and with a 1" blast pattern, it's perfect for small jobs and touch ups.

4713-0001

Inspection Door Curtain



This sandblasting curtain was developed to meet the demands of present day fine line carving. The Inspection Door provides an unobstructed opening 24" high, permitting time saving inspection of lettering depth and carving from outside the room.

The curtain has upper and lower rubber sheeting, enabling the entire blast window area to be moved up or down with ease.

Sizes:
7' 6" x 7' 6" wide curtain 4704-0034

| Type | Size | Item # |
|-------------------------------------|-------|-------------|
| NOZZLE APRON 4PLY | 5' 8" | 99-695-0132 |
| NOZZLE APRON 4PLY | 7' 6" | 99-695-0146 |
| CURTAIN SHEET (EACH) UPPER/LOWER | 5' 8" | 4704-0011 |
| CURTAIN SHEET (EACH) UPPER/LOWER | 7' 6" | 4704-0012 |

HIRONS Automatic Sandblast

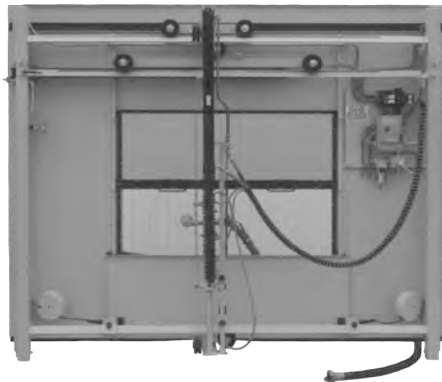

The Hirons sandblast machine offers automatic at its best. This is a single unit that mounts against the opening of the blast room so no other curtain is needed. It operates on two cubic feet of air per minute and on 115 volt current for controls. Vertical travel on both the 8' & 10' models is 30", and can be extended to 55" with a simple adjustment. The 8' model has a horizontal range of 60" and the 10' range is 84". This easily operated automatic produces a quality product day after day. It makes every inscription letter perfect.

| | |
|--------------|-----------|
| Model J - 8' | 4704-0016 |
| Model J 10' | 4704-0017 |

***Please call for more
information and pricing***

| | |
|---------------------------------------|-------------|
| Counter, Preset for Sandblast Curtain | 99-373-0007 |
| Extended Vertical Range Option | 99-373-0048 |
| Rubber Curtain Complete Option | 99-373-0041 |
| Protective End Panels | 99-373-0056 |

Rubber Diaphragm Sheeting



| | |
|--------------------|-----------|
| 1/16" Thick x 16"W | 4710-0001 |
| 1/4" Thick x 48"W | 4710-0005 |

Ideal material for room fronts and as protective sheeting against blasting or water spray, also useful as diaphragms and gaskets. Curtain nozzle aprons are made to order from this material. Supply width, length and number of plies.



ABC Automatic Sandblast Room

Easy to install and simple to operate!

Package includes ✓

| ✓ | Component | Item # |
|-----|------------------------------------|-------------|
| ✓ | ABC Electric Curtain | 4708-0019 |
| ✓ | Metal Room | 4711-0008 |
| ✓ | Auger System | 4701-0039 |
| ✓ | Rubber Sheeting | 4710-0004 |
| ✓ | Inside Roller Conveyer | 4711-0009 |
| ✓ | Abrasive Pick Up (without hopper) | 4701-0038 |
| ✓ | Empire 650S | 4708-0022 |
| OPT | GCT Dust Collector Model 2-4 | 4706-0061 |
| OPT | GCT Dust Collector Model 2-8 | 4706-0060 |
| OPT | Start/Stop Option | 99-065-0046 |
| OPT | Add. 10ft Roller Conveyer w/Stands | 4711-0010 |



ABC Automatic Electric Sandblast

Blasting with the ABC Automatic Electric sandblast is the answer to fast, accurate production at lower costs. The ABC Sandblast does not require an additional curtain and is enclosed to minimize abrasive loss. The blasting nozzle of the ABC is always directed squarely at the work at all times for sharp straight line etching with no hint of undercutting.

10' Unit with curtain 4708-0019

Overall Height: 11' 8" x 7' 7" x 20" deep
 Frame Size: 9' 10" x 7' 6" high
 Motor: 220v 1 phase or 230v 3 phase
 Direct Drive motors
 Var. Speed control

Please call for more information and pricing

Electric Start/Stop Valve 99-065-0046

TURBO BLASTER

Computerized Sandblast Curtain

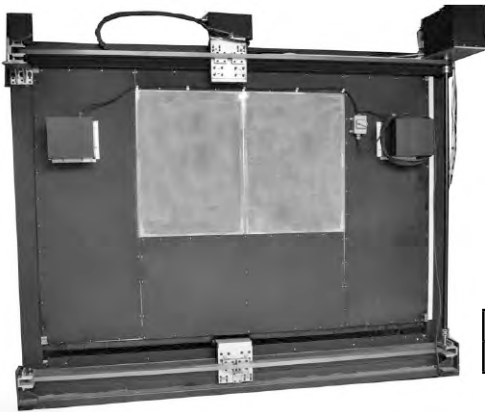

Turbo Blaster will save you time because it only blasts the areas with carvings and lettering instead of the entire stone. Computer arm is 110V - 20amp. Energy efficient.

Remote Control Pendant

Precision Controlled Venturi Nozzle



| | | | |
|---------------------------|-----------|--------------------------------------|-------------|
| 8' Turbo Blaster Curtain | 4711-0006 | Install & Training for Turbo Blaster | 99-008-0007 |
| 10' Turbo Blaster Curtain | 4711-0007 | Crating Charge for Turbo Blaster | 99-008-0008 |

QuickSand - Computerized Sandblast Curtain

Allen Datagraph has applied its innovative motion control technologies to efficiently automate the sandblast process. The QuickSand systems includes the automated sandblast "curtain" and Allen's exclusive Blast Ready software with easy to use job set-up templates.

Optimizes the blast direction to only the intended areas on the substrate resulting in increased productivity saving up to 50% in costs. It automatically directs the nozzle through the desired image path & controls the depth of impression through management of the blast duration time, avoiding "stencil burn". Its circular nozzle rotation process is adjustable allowing the creation of the desired edge/line definition.

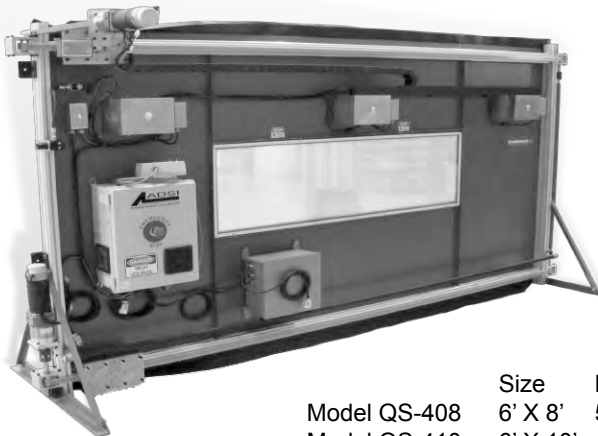

| | | |
|--------------|------------------|------------|
| Model QS-408 | Size | Blast Area |
| Model QS-410 | 6' X 8' | 50" x 84" |
| Speed | 6' X 10' | 50" x 108" |
| Interface | 10 in/s (25cm/s) | RS232-C |

Please call for more information and pricing

HR Automatic Sandblast Room

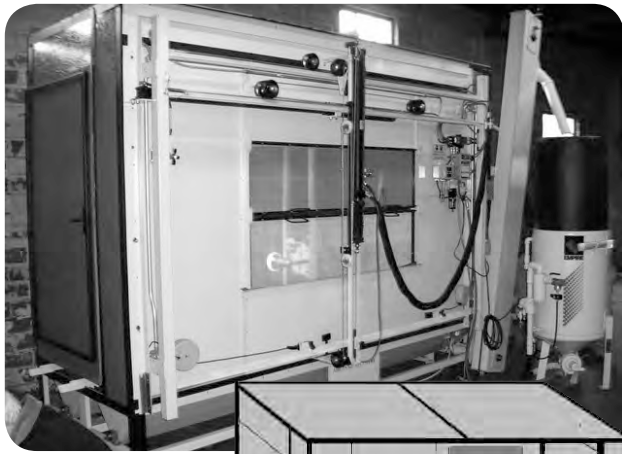

Features:

- Eliminate shoveling abrasive
- No under flooring pit required
- Large viewing screens open wide for easy access to work area
- 7' horizontal travel and optional 4'4" vertical travel
- Few moving components exposed to abrasive blast
- 120 volt power

Blast Zone:
84" horizontal with 30" vertical in a 55" range - Optional 52" vertical.

| | |
|----------------------------------|-----------------|
| 10 ft. Automatic Sandblaster | 4704-0017 |
| Abrasive Recovery System | 4701-0024 |
| Prefabricated Sandblasting Booth | 4711-0004 |
| Power Cart & Track Conveyer | 4701-0034 -0035 |
| Empire 650 Sandblast Tank | 4708-0022 |
| GCT Boron Venturi Nozzle | |
| Crating Charge | |

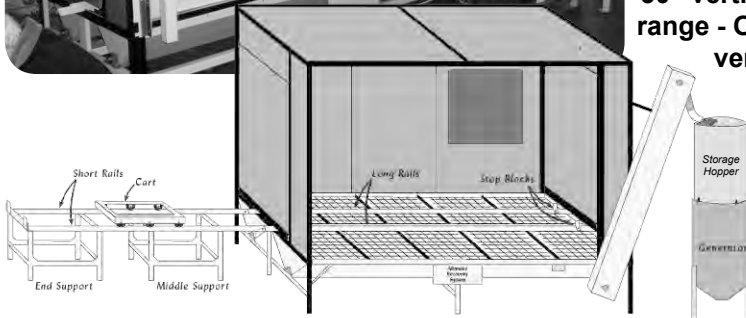

This Abrasive Recovery System covers the entire bottom of an enclosed sandblast booth to capture and recycle spent abrasives continuously at an excess of 1000 lbs/hr flow rate. The low profile collection pans fit under standard roller conveyors or mounted below the floor with optional Floor Grate.

Please call for more information & pricing

GCT Dust Collectors

- Cartridge style downward flow dust collector
- 4 cartridge filters for up to 1,016 sq ft of filter media
- 6 cartridge filters for up to 1,524 sq ft of filter media
- 8 cartridge filters for up to 2,032 sq ft of filter media
- Nano fiber elite, merv 15 filters
- 5 HP motor/blower rated for 2,000 CFM @ 10" (4 Cart.), 4,500+ CFM (6 Cart.) 6,000+ CFM (8 Cart.)
- Reverse pulse filter cleaning system
- Filters are 99.9% efficient
- Dwyer pulse control timer board with built-in digital pressure gage
- Drum lid with latch kit
- Quick-lock, easy-access filter doors
- 5 year material and craftsmanship warranty
- Goyen solenoids and diaphragms
- **Made In the USA**



| | |
|-------------|-----------|
| 4 Cartridge | 4706-0061 |
| 6 Cartridge | 4706-0062 |
| 8 Cartridge | 4706-0060 |

VACUUM Filter Bags

Filter bags for are always in stock in both 5'6 and 6' lengths. Please give bag size and filter serial number when ordering.



| | |
|-------|-------------|
| 5' 6" | 99-695-0210 |
| 6' | 99-695-0211 |

Dust Collection Bags

Replacement bags for Ruemelin dust collectors



| | |
|------|------------|
| 5'6" | 99-04-0186 |
| 6' | 99-04-0187 |

PNEUMATIC Abrasive Pick-Up

This Pneumatic Abrasive Pickup operates on compressed air for quick recovery of spent abrasive. Works on any flat top generator with side of tank controls. Installation instructions call for piping in air and burying hopper at floor level in the blast room. The abrasive is drawn up into the storage tank by suction at a rate of from 65 to 80 pounds a minute. For completely automatic operation, an optional below the floor room size hopper is also available, so the operator never touches the abrasive.



4701-0023

Sandblast tank not included

Novatek Novair Air Filtration System

- 2 hp - Two speed, thermally protected motor
- 2,000 on high - 1,000 on low CFM
- 115 V, 15 amp, 60Hz
- Horizontal Configuration
- Uses Standard 24x24x11.5 HEPA filters
- Dent proof, leak proof polyethylene.
- Light weight & virtually indestructible



4706-0065

Novair Filters



24" x 24"
 3 Ply filtrates to 0.5 microns
 Wash and reuse

General 4706-0064



24" x 24" x 11.5"
 99.99% at 0.3 micron

Hepa 4706-0063

Please call for more information & pricing

Ceramic Nozzles



Sapphirite Nozzles are resistant to wear, abrasion and breakage, because they are made of high density alumina. Gauge checked for uniformity of shape and accuracy of bore, these nozzles fit better and last longer.

| | | | |
|--------|-------|-----------|-----------|
| No. 1 | 3/32" | Blasting | 3502-0015 |
| No. 1 | 1/8" | Blasting | 3502-0006 |
| No. 1 | 5/32" | Blasting | 3502-0009 |
| No. 1 | 3/16" | Blasting | 3502-0007 |
| No. 1 | 1/4" | Blasting | 3502-0005 |
| No. 1 | 5/16" | Blasting | 3502-0008 |
| No. 2 | 3/32" | Lettering | 3502-0002 |
| No. 2 | 1/8" | Lettering | 3502-0001 |
| No. 3L | 3/32" | Shaping | 3502-0003 |
| No. 3L | 5/64" | Shaping | 3502-0004 |

Duro Carbide Nozzles

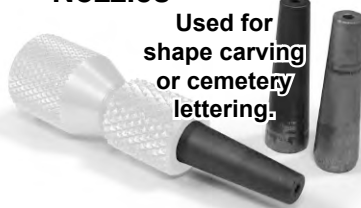

Used for shape carving or cemetery lettering.

A solid cone of dense carbide for longer wear and tight abrasive control. The longest wearing carving nozzle available.

| | |
|-------|-----------|
| 5/64" | 3501-0002 |
| 3/32" | 3501-0001 |

GCT Hardened Tungsten Carbide Nozzles

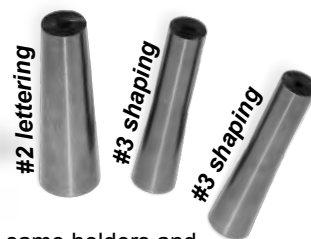

Uses same holders and #2 and #3 ceramic nozzles

| | | |
|-----------|-----------|--|
| #2 3/32" | 3510-0009 | For lettering and shape carving |
| #3L 3/32" | 3510-0010 | |
| #3L 5/64" | 3510-0011 | |

T-Series Nozzles

Tungsten, Carbide Straight Bore Nozzle, 3/4 Thread x 1-5/8" Length, All Steel Jacket and threads. Thread Style: 3/4 -14 N.P.S. A great venture nozzle at an economical price.



| | |
|--------------------|-----------|
| 3/16" | 3509-0026 |
| 1/4" | 3510-0007 |
| 1/2" Nozzle Holder | 3505-0035 |

Carbide Nozzles



Cap style carbide shape nozzle. Will outlast ceramic nozzles 10 to 1. The nozzle is built right into the cap forming a single unit insuring a proper fit between hose and holder.

| | |
|-------|-----------|
| 5/64" | 3501-0029 |
| 3/32" | 3501-0030 |

Tungsten & Silicon Carbide Nozzles

These commercial sized blast nozzles are available in wide venturi and double venturi styles. Designed for maximum blast cleaning coverage and greater productivity.



| | |
|-------|-----------|
| 3/16" | 3509-0002 |
| 1/4" | 3509-0020 |
| 5/16" | 3509-0006 |
| 3/8" | 3509-0007 |
| 1/2" | 3509-0008 |

GCT & NORBIDE Boron Carbide Venturi Nozzles

The Venturi design doubles abrasive acceleration for greater impact to provide up to thirty percent faster production. The wider, uniform blasting pattern keeps more abrasive working for greater action in the cuts.



| GCT Nozzles | |
|--------------------|-----------|
| Venturi 3/16" | 3509-0014 |
| Venturi 1/4" | 3509-0016 |
| Venturi 5/16" | 3509-0017 |
| Venturi 3/16" F4SV | 3509-0027 |
| Venturi 1/4" F4SV | 3509-0028 |

| NORBIDE Nozzles | |
|-----------------|-----------|
| Venturi 5/16" | 3509-0015 |
| Venturi 1/4" | 3509-0013 |
| Venturi 3/16" | 3509-0012 |

GCT Boron Carbide Nozzles



| GCT Nozzles | |
|---------------|-----------|
| Tapered 3/16" | 3501-0034 |
| Flange 3/16" | 3501-0035 |



| GCT Nozzles | |
|---------------|-----------|
| Venturi 3/16" | 3509-0034 |
| Venturi 1/4" | 3509-0035 |
| Venturi 5/16" | 3509-0036 |

GCT & NORBIDE Boron Carbide Nozzles

The core or flange shaped Boron Carbide Nozzles are the longest lasting and most durable straight bore nozzles available. Unmatched for economical sandblasting.



| GCT Nozzles | |
|---------------|-----------|
| Tapered 3/16" | 3501-0016 |

| NORBIDE Nozzles | |
|-----------------|-----------|
| Flange 1/8" | 3501-0003 |
| Flange 5/32" | 3501-0005 |
| Flange 3/16" | 3501-0007 |
| Flange 1/4" | 3501-0011 |
| Tapered 1/8" | 3501-0004 |
| Tapered 5/32" | 3501-0006 |
| Tapered 3/16" | 3501-0008 |
| Tapered 7/32" | 3501-0010 |
| Tapered 1/4" | 3501-0022 |

Gold Band Nozzle and Holder

Gold band holder with included cap, allowing you to get deeper while carving.



Especially effective for maximum depth when deep cutting delicate shape carved flowers.

| | | |
|--------------|---------|-----------|
| Deep Carver | Carbide | 3501-0032 |
| Holder w/Cap | - | 3505-0013 |

DURO Shaping Nozzle Holder



1/4" x 3" XH Hose Nipple. No. 84CH
Nozzle Adapter. No. 84D
Nozzle cap for Duro Nozzles

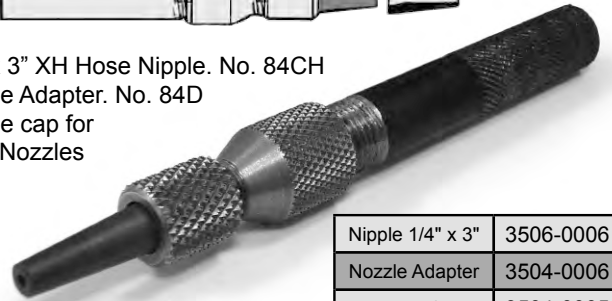

| | |
|------------------|-----------|
| Nipple 1/4" x 3" | 3506-0006 |
| Nozzle Adapter | 3504-0006 |
| Nozzle Cap | 3504-0005 |

NO.2 Ceramic Nozzle Holder



1/4" x 3" XH Hose nipple.
AR-C Nozzle cap for No. 2 nozzles.

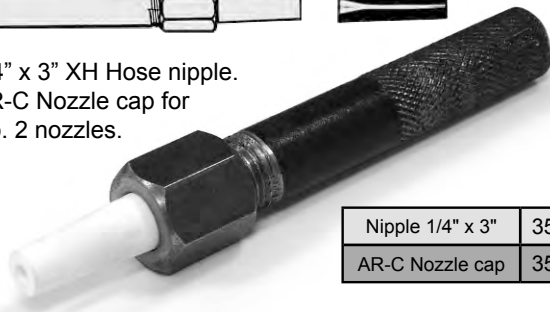

| | |
|------------------|-----------|
| Nipple 1/4" x 3" | 3506-0006 |
| AR-C Nozzle cap | 3504-0003 |

NO.3 Ceramic Nozzle Holder



1/4" x 3" XH Hose nipple. No. 84-CH
Nozzle adapter. No. 84-C
Nozzle cap for No. 1 nozzles.

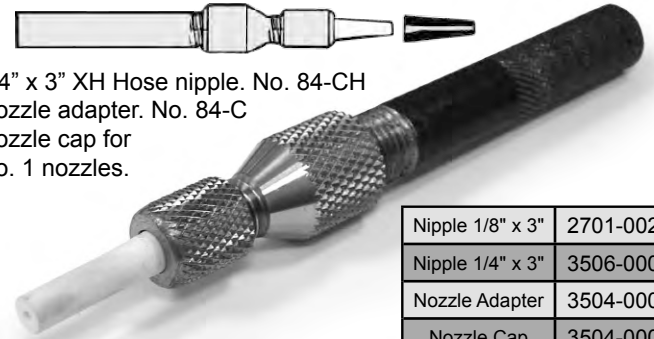

| | |
|------------------|-----------|
| Nipple 1/8" x 3" | 2701-0023 |
| Nipple 1/4" x 3" | 3506-0006 |
| Nozzle Adapter | 3504-0006 |
| Nozzle Cap | 3504-0004 |

Lindsay Style NO.1

| | |
|----------------------|-------------|
| 1/2" PT Screw | 99-455-0115 |
| Nozzle Cap | 99-455-0117 |
| Rubber Washer | 99-455-0004 |
| 1/2" I.D. Hose Coup. | 99-455-0111 |



Nozzle Holder Base TYPE-1 66-B 1/2"NPT
Nozzle cap TYPE-1 LARGE
Rubber washer for TYPE-1 Ceramic nozzles
1/2" I.D. Hose-end coupling , Nipple

Hose End Couplings



| | |
|----------------------|-------------|
| 3/4" I.D. Hose Coup. | 99-455-0126 |
| 1" I.D. Hose Coup. | 99-455-0140 |

Hose couplers with base and nipple.
Also includes rubber liner and ring.

| Size of Generator Nozzle | Gauge Pressure in Pounds per Square Inch | | | | Horse Power | Sand Discharged per Hour |
|--------------------------|--|---------|---------|----------|-------------|--------------------------|
| | 60 lbs. | 70 lbs. | 80 lbs. | 100 lbs. | | |
| 3/32" | 9 | 11 | 12 | 15 | 3 to 6 | 100 lbs. |
| 1/8" | 17 | 19 | 21 | 26 | 5 to 7-1/2 | 200 lbs. |
| 3/16" | 38 | 43 | 47 | 58 | 6 to 15 | 500 lbs. |

| Size of Generator Nozzle | Gauge Pressure in Pounds per Square Inch | | | | Horse Power | Sand Discharged per Hour |
|--------------------------|--|---------|---------|----------|-------------|--------------------------|
| | 60 lbs. | 70 lbs. | 80 lbs. | 100 lbs. | | |
| 1/4" | 67 | 76 | 85 | 103 | 8 to 21 | 900 lbs. |
| 5/16" | 105 | 119 | 133 | 161 | 12.5 to 33 | 1,200 lbs. |
| 3/8" | 151 | 171 | 191 | 232 | 18 to 48 | 1,700 lbs. |
| 1/2" | 268 | 304 | 340 | 412 | 41 to 85 | 3,000 lbs. |

Carbide Nozzle Holders

Convert the standard type 1 ceramic nozzle holder to accommodate the Norbide Cone, Flange or Venturi Nozzles.

Lathe turned and machined aluminum caps offer the best nozzle fit and easiest conversion for hand blast operations. Utilizes the R-149 nozzle screw and the thicker no. 50 rubber washer. W-2 Flange carbide nozzle cap. W-1CA Cone Carbide nozzle cap. W-2V Venturi Carbide nozzle cap.



| | | | |
|-----------------------|-----------|---------------|-----------|
| CAP W2 Flange (Alum) | 3504-0022 | 1/2" PT Screw | 3506-0009 |
| CAP W2 Taper (Alum) | 3504-0023 | 3/4" PT Screw | 3506-0010 |
| CAP W2 Venturi (Alum) | 3504-0024 | Rubber Gasket | 3506-0002 |

NO.1 Ceramic Nozzle Holder



| | |
|--------------------|-----------|
| Nipple 1/2"ID x18" | 3506-0007 |
| Nipple 3/4"ID x18" | 3506-0008 |
| 1/2" PT Screw | 3506-0009 |
| 3/4" PT Screw | 3506-0010 |
| Rubber Gasket | 3506-0004 |
| W-1 Nozzle Cap | 3504-0015 |

Hose nipple 1/2" x 18" - 3/4" x 18".
R-149 Nozzle screw 1/2" or 3/4" P.T.
No. 49 Nozzle rubber gasket.
W-1 Nozzle cap for No. 1 ceramic nozzles.

GCT "M" Series External Nozzle Holders

Steel sleeve holder made for 1" I.D. sandblast hose with a 1-1/2" or 1-15/16" O.D.



| | |
|-------------------------|-------------|
| CAP Flange (Alum) | 3504-0009 |
| CAP Flange (Brass) | 3504-0010 |
| CAP Carb. Taper (Alum) | 3504-0011 |
| CAP Carb. Taper (Brass) | 3504-0012 |
| CAP Venturi (Alum) | 3504-0013 |
| CAP Venturi (Brass) | 3504-0014 |
| 1" Sleeve (Steel) | 99-400-0010 |
| Gasket - Venturi | 3506-0023 |
| Gasket - Str. Bore | 3506-0022 |

Threaded Nozzle Holders

| | |
|----------------|-----------|
| 1/2" (Brass) | 3505-0025 |
| 3/4" (Alum) | 3505-0029 |
| 3/4" (Brass) | 3505-0004 |
| 1" (Brass) | 3505-0005 |
| 1-1/4" (Brass) | 3505-0012 |



Designed for heavy duty use and accurate assembly of threaded blast nozzles and blast hose. True air-abrasive directional stream from hose to nozzle gives greater nozzle economy and less abrasive breakdown. Manufactured of bronze to avoid rust and "freezing" of nozzle and holder.

Sleeve Type Boron Carbide Nozzle Holders

This type of holder slips over the blast hose so the hose fits squarely against a gum rubber gasket to form a leak proof seal between nozzle and hose. When this is done properly each time, there is no chance of the abrasive contacting metal to cause blowout of the cap. Proper sealing each time plus occasional replacement of worn gaskets assure years of trouble-free operation.

Steel sleeve for 3/4" I.D. blast hose.

| | |
|--------------------|-----------|
| Gasket - Venturi | 3505-0002 |
| Gasket - Str. Bore | 3506-0017 |

| | |
|---------------------|-----------|
| CAP Ceramic (Alum) | 3504-0002 |
| CAP Cone (Alum) | 3504-0017 |
| CAP Flange (Alum) | 3504-0016 |
| CAP Venturi (Alum) | 3504-0018 |
| 3/4" SLEEVE (Steel) | 3505-0023 |



Norton Stoneblast Abrasives

A hard durable Super Premium Abrasive made of Aluminum Zirconium Oxide and is our most popular abrasive for full production shop users. Excellent for monumental sandblast lettering and industrial and general sandblasting. Slow to break down and is therefore long lasting. Mixed particle size 36/60 grit.

Comes in 50 lbs. Boxes.

| | |
|--------|-----------|
| #30/60 | 0111-0001 |
|--------|-----------|



Norton MCA1360 Abrasives

Norton MCA1360 Abrasives are the Top-of-the-line Super Premium Stone Blasting Abrasives. Made from pure Aluminum Zirconium Oxide it will provide consistently superior results. Initially costs more than other abrasives, but is cost effective with it's reclaiming value.

Comes in 50 lbs. Boxes.

| Grit | Item # |
|------|-----------|
| #30 | 0111-0004 |
| #46 | 0111-0003 |
| #60 | 0111-0006 |



The granite city tool line of abrasive.

Jet Stream is the perfect blend for all of your sand-blasting medium needs. Zirconia alumina is a mixture of zirconium oxide and aluminum oxide.

0107-0003

Available in 50 lbs. Bags.

Dynablast Abrasives

Pure Aluminum Oxide premium blasting abrasive. Coarse grits are used in monumental sandblast lettering, industrial blasting, steel blasting and cleaning. Fine grits are used in monumental shape carving and general sandblasting when smooth surface textures are needed.

Available in 50 lbs. Bags.



| Grit | Item # |
|------|-----------|
| #30 | 0104-0001 |
| #36 | 0104-0002 |
| #60 | 0104-0003 |
| #80 | 0104-0004 |
| #120 | 0104-0005 |
| #180 | 0104-0006 |

Thunderblast Garnet Sand

Garnet Sand (Almandine) is an economical sandblast abrasive that is fast cutting and reusable.

30/60 grit in 55lb. bags

0116-0002



Econoblast

Packaged in 50 lbs. Bags.

ECONOBLAST is an economical, safe and "silica free" abrasive made of pure white aluminum oxide abrasive, and graded in a 60/80 grit blend.

Ideal for cemetery lettering
ECONOBLAST is proven to be the most cost effective blasting abrasive.

0101-0004



Steel Shot

Nothing stuns granite like steel, for greater contrast and whiter panels. Use steel shot for delicate shape carving, especially for fine detail and the whitest natural panels. Size No. S-170 is preferred by many for this dual purpose.

Available in 50 lbs. Bags.

| Grit Size | Item # |
|-----------|-----------|
| S-170 | 0110-0004 |
| S-230 | 0110-0005 |



Sinter Ball

This is a very durable long lasting material that lasts 2 to 3 times longer than aluminum oxide and is much more economical. It is not affected by surrounding humidity, contains no free-silica, and does not rust.

Available in 50 lbs. Bags.

#20/40 0109-0001



Lithichrome Shadow

This product enhances all types of stone by providing contrast in the lettering and carving backgrounds. It comes in Transparent Grey, Dark Grey, Blue Grey, Black, Brown, Bronze and Abrasive Shade colors. May be applied with brush, airmite gun or aerosol propellant. Use this product to enhance your work.



| Color | Quart | Gallon |
|--------------|-----------|-----------|
| Abrasive SHD | 3713-0009 | 3713-0017 |
| Black | 3713-0010 | 3713-0018 |
| Blue Gray | 3713-0011 | 3713-0019 |
| Brown | 3713-0012 | 3713-0020 |
| DK Grey | 3713-0014 | 3713-0022 |
| Trans. Gray | 3713-0015 | 3713-0023 |
| Grey Marble | 3713-0016 | 3713-0024 |

Lithichrome Hilite

Used for whitening flashed inscription panels and carvings on all colors of granite. Hilite duplicates the finest "steeled" effect. Excellent weathering because Hilite particles are fine enough to become embedded in the sub-pores of the granite. Apply lightly for best effect. Comes in white for granite and in blue tint for the blue-grey marbles.



| Hilite | | Blue | |
|--------|-----------|--------|-----------|
| Size | Item # | Size | Item # |
| Pint | 3708-0001 | Quart | 3708-0006 |
| Quart | 3708-0002 | Gallon | 3708-0005 |
| Gallon | 3708-0003 | | |

Lithichrome Solvent

Used for cleaning Airmite spray gun or air brush. May be used for removing Hilite or Shadow from the stone before they have set. Also used with Lithco Colors for thinning when spraying is necessary. This is the only positive cleaner for Lithichrome products.



| Size | Item # |
|--------|-----------|
| Pint | 3714-0001 |
| Quart | 3714-0002 |
| Gallon | 3714-0003 |

Lithichrome Stone Paint

AKEMI Stone Paint

| Color | Item # |
|----------------|-----------|
| Antique Gold | 3701-0008 |
| Antique Silver | 3701-0009 |
| White | 3701-0010 |



1-component lacquers on the basis of air-dried alkyd resins. Fast-drying, high-resistance towards light and weathering and high covering power.

| Color | Item # |
|--------|-----------|
| Black | 3701-0001 |
| Brown | 3701-0002 |
| Grey | 3701-0003 |
| Hilite | 3701-0004 |
| Clear | 3701-0006 |
| Gold | 3701-0005 |



Available in 12 ounce aerosol cans. Convenient in operations where air is not available. Ideal for use in the cemetery.

Lithichrome Saw Sheen

Use for producing a subtle tone for contrast in deep cut lettering. Also, Saw Sheen is designed to bring out the color on sawed surfaces to produce a honed finished effect.



| Size | Item # |
|--------|-----------|
| Pint | 3712-0001 |
| Quart | 3712-0002 |
| Gallon | 3712-0003 |

| Color | 2 oz | 6 oz | Pint | Quart | Gallon |
|-------------|-----------|-----------|-----------|-----------|-----------|
| LT Blue | 3704-0011 | 3704-0066 | 3704-0093 | 3704-0120 | 3704-0147 |
| Blue | 3704-0001 | 3704-0055 | 3704-0082 | 3704-0109 | 3704-0136 |
| Black | 3704-0002 | 3704-0056 | 3704-0083 | 3704-0110 | 3704-0137 |
| Bright Gold | 3704-0003 | 3704-0057 | 3704-0084 | 3704-0111 | 3704-0138 |
| LT Brown | 3704-0012 | 3704-0067 | 3704-0094 | 3704-0121 | 3704-0148 |
| WM Brown | 3704-0025 | 3704-0080 | 3704-0107 | 3704-0134 | 3704-0161 |
| DK Brown | 3704-0005 | 3704-0059 | 3704-0086 | 3704-0113 | 3704-0140 |
| LT Green | 3704-0014 | 3704-0069 | 3704-0096 | 3704-0123 | 3704-0150 |
| Leaf Green | 3704-0013 | 3704-0068 | 3704-0095 | 3704-0122 | 3704-0149 |
| Green #5 | 3704-0008 | 3704-0063 | 3704-0090 | 3704-0117 | 3704-0144 |
| DK Green | 3704-0027 | 3704-0060 | 3704-0087 | 3704-0114 | 3704-0141 |
| Flesh | 3704-0006 | 3704-0061 | 3704-0088 | 3704-0115 | 3704-0142 |
| Grey | 3704-0009 | 3704-0064 | 3704-0091 | 3704-0118 | 3704-0145 |
| Gold | 3704-0007 | 3704-0062 | 3704-0089 | 3704-0116 | 3704-0143 |
| Bronze | 3704-0004 | 3704-0058 | 3704-0085 | 3704-0112 | 3704-0143 |
| LT Yellow | 3704-0015 | 3704-0070 | 3704-0097 | 3704-0124 | 3704-0151 |
| GLD Yellow | 3704-0010 | 3704-0065 | 3704-0092 | 3704-0119 | 3704-0146 |
| Maroon | 3704-0016 | 3704-0071 | 3704-0098 | 3704-0125 | 3704-0152 |
| Orange | 3704-0017 | 3704-0072 | 3704-0099 | 3704-0126 | 3704-0153 |
| Violet | 3704-0024 | 3704-0079 | 3704-0106 | 3704-0133 | 3704-0160 |
| Purple | 3704-0018 | 3704-0073 | 3704-0100 | 3704-0127 | 3704-0154 |
| Pink | 3704-0019 | 3704-0074 | 3704-0101 | 3704-0128 | 3704-0155 |
| Red | 3704-0020 | 3704-0075 | 3704-0102 | 3704-0129 | 3704-0156 |
| Rust Red | 3704-0021 | 3704-0076 | 3704-0103 | 3704-0130 | 3704-0157 |
| Silver | 3704-0022 | 3704-0077 | 3704-0104 | 3704-0131 | 3704-0158 |
| Tan | 3704-0023 | 3704-0078 | 3704-0105 | 3704-0132 | 3704-0159 |
| White | 3704-0026 | 3704-0081 | 3704-0108 | 3704-0135 | 3704-0162 |

Lithichrome Stone Paint

Call for the color chart to put colors to work on your product.



From every weathering angle Lithco colors are as durable as any color materials available today. Ultraviolet light is the chief source of pigment and binder deterioration and Lithco colors are compounded from the most UV resistant pigments and resins known. Twenty eight permanent colors are available.

See Color Guide on inside back cover

Lithco Clear

This silicone bonding resin is the nearest organic material to natural silica in weathering resistance. Application over any Lithco Color as a clear "over coat" gives assurance that the color has maximum protection against weathering.

| Size | Item # |
|--------|-----------|
| Pint | 3716-0001 |
| Quart | 3716-0002 |
| Gallon | 3716-0003 |



Permabond

Permabond is used primarily for reducing the color tone of either Hilite or Shadow, when less color intensity is desired. Does not thin out or affect the bonding strength of either. May be used as an additional protective coat over Shadow Lithichrome and similar treated surfaces. Apply thinly but thoroughly.

| Size | Item # |
|--------|-----------|
| Pint | 3711-0001 |
| Quart | 3711-0002 |
| Gallon | 3711-0003 |



Bondri 75

Use for both polished and unpolished granites. Not quite as strong in silicone as Super Bondri, but it is a high quality repellent at moderate cost. In use for over twenty years with satisfactory results.

| Size | Item # |
|--------|-----------|
| Quart | 3703-0001 |
| Gallon | 3703-0005 |



Super Bondri

Use as a highly potent water repellent on polished granite surfaces only. This permanent product has a high silicone content, several times the amount of pure silicone as is found in average water repellents. Product may slightly darken unpolished granite.

| Size | Item # |
|--------|-----------|
| Quart | 3703-0003 |
| Gallon | 3703-0006 |



Lithco Hi-Polish

Hi-polish dresses up polished granite in making it permanently darker, more lustrous and completely impervious to water.

May be used to equalize color deficiencies and even staining, provided the staining is not much darker than the color change in Hi-polish.

Puts a higher gloss on most polished surfaces.

| Size | Item # |
|--------|-----------|
| Pint | 3707-0001 |
| Quart | 3707-0002 |
| Gallon | 3707-0003 |



Joint and Bottom Sealer

Offers the only practical method for preventing markers, bases, monoliths, ledgers and similar memorials from drawing moisture out of the earth. Such moisture is often laden with alkali or acid and leaf stains.

Be particular and protect your best work and especially porous granites.

| Size | Item # |
|--------|-----------|
| Quart | 3709-0001 |
| Gallon | 3709-0002 |



Airmite Spray Gun

3702-0020

| | |
|-------------------|-----------|
| Glass Jar & Lid | 3702-0007 |
| Plastic Jar & Lid | 3702-0006 |



The Airmite spray gun is the most efficient and economical sprayer for handling all the Lithichrome products, because it is designed solely for this purpose. It is easy to keep clean, easy to service, and inexpensive. Glass and plastic replacement jars available by the dozen or single.

K-Grip Spray Gun



3702-0034

| | |
|----------------|-----------|
| Plastic Bottle | 3702-0035 |
| Plastic Cap | 3702-0036 |

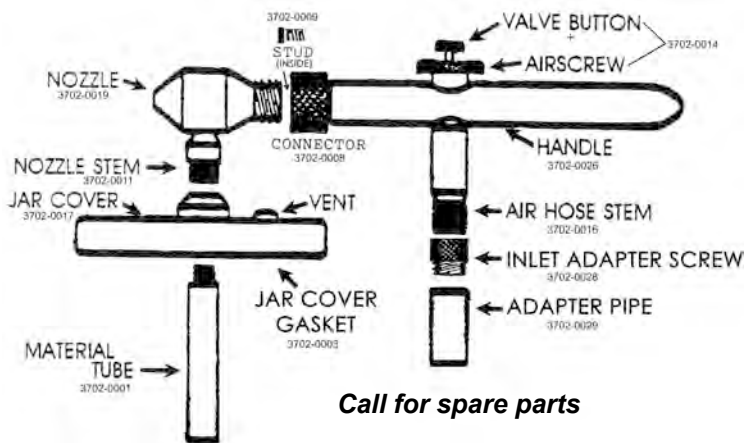

Requirements:

3/4hp compressor or larger
3CFM @ 90PSI

(Spraying at lower pressures will require less CFM)

The spray pattern is always circular and can range from 1/2" to 3-1/2" diameter depending on pressure setting, viscosity of material and distance held from work piece.

Stonedri

Silicone Water Repellents for limestone, mortar, concrete or brick. The best water repellent for specific use on any of the above named materials. Stonedri meets all government specifications. 1 Gallon.



Lithco Fastmask

Use this putty-like material to protect shadow and edges of letters in the single process operation. Ideal for masking shadow in one process shape carving. Presses into incisions with fingers or putty knife. Washes out with water. Available in 25 lb. containers



3706-0001

3M 8210 Filter Mask

- NIOSH, N95
- Adjustable nose piece
- Box of 20

4507-0002



Moldex® 2200 Particulate Respirators

- NIOSH, N95
- Easy fit, more comfort
- Box of 20

4507-0061



Moldex® 2700 Particulate Respirators

- NIOSH, N95
- Vent hot air, stay cooler
- Easy fit, more comfort
- Box of 10

4507-0045



Moldex® 1200 Particulate Respirators

- NIOSH, N95
- For use with stone dusts
- Easy fit, more comfort
- Box of 20

4507-0062



3M 8211 Filter Mask

- NIOSH, N95
- Vent air, stay cooler
- Easy fit, more comfort
- Box of 10

4507-0049



MSA Advantage® 200 LS Half-Mask Respirator

- NIOSH
- Soft, durable face piece

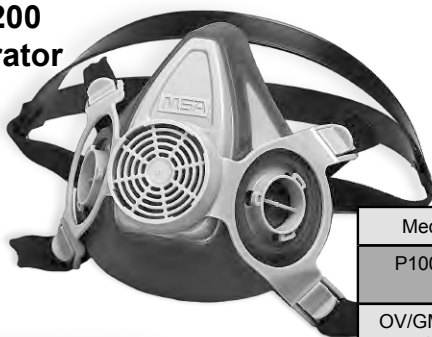

| | |
|--|-----------|
| Medium Respirator | 4507-0015 |
| P100 Filter Cartridge Dust 2-Pk | 4507-0004 |
| OV/GMA Filter Cartridge Chemical 2-Pk | 4507-0014 |



Carbon Monoxide Monitor/Alarm

The CMS-3 monitor detects carbon monoxide in the breathing-air supply and triggers audible, visual, and vibratory alarms when CO is detected in concentrations of at least 10 parts per million. The alarms alert the operator to an unsafe condition. Dimensions: 2.5" w x 1.7" h x 0.9" d

4507-0069

Nova 3 Helmet

The Nova 3® series respirator combines breakthrough protection technology with advanced comfort and functionality, surpassing even the most rigorous industry standards and the demands of the most quality-conscious companies.

4502-0014



Model CD-85 Sandblast Hood

New durable long lasting canvas hood with larger viewing area than type 30 helmet. 5" x 7" plastic lenses. Includes an adjustable hard hat under the hood, replaceable lens and cover screen.



Use with respirator for outside blasting

| Description | Item # |
|------------------|-----------|
| Hood | 4509-0009 |
| Sight Screen | 4510-0035 |
| 5.5x7 Rep. lens | 4510-0022 |
| 5x7 lenses 100pk | 4510-0032 |



Use with respirator for outside blasting

Type 30 Plain Hood

Protects head & shoulders from ricocheting abrasive blasting. Features lightweight duck hood cover with ventilated screen openings on sides and back, & a bump cap with fully adjustable head gear. With replaceable lens & cover screen.

| Description | Item # |
|------------------------|-----------|
| Hood | 4509-0003 |
| 3x5 Screen | 4510-0008 |
| 3x5 Mylar Lenses 100pk | 4510-0019 |
| 3x5 Thick Mylar Lens | 4510-0006 |



MB30 Hood Respirator

For general outside sandblasting applications. They are also being used by Outside Cemetery Sandblasting Professionals who want air conditioning devices for user comfort on hot summer days. MSHA/NIOSH APPROVED. Can accommodate a Bullard hard hat. Cannot use air conditioner devise with low pressure free-air pumps. Includes: hood, suspension, breathing tube assembly with belt, and outer lens.

Options:

- V-20-100ST (100' 1/2" hose for free air pumps)
- V-20-50ST (50' 1/2" hose for free air pumps)
- 469-6 (25' starter 3/8" hose for H.P. systems)
- 545-4 (25' extension 3/8" hose used with 469-6)
- 545-7 (50' extension 3/8" hose used with 469-6)
- 545-8 (100' extension 3/8" hose used with 469-6)
- AC-100: Air Conditioner for H.P. systems only.

| Description | Item # |
|------------------------------|-----------|
| Hood Light Duty Respirator | 4509-0018 |
| Respirator Light Duty | 4507-0039 |
| Hood High Pressure Adj. Flow | 4509-0022 |
| MB1 Outer lens .020 10/pkg | 4510-0018 |
| 20-LC Mylar covers 25/pkg. | 4510-0014 |



Bullard® 88 Supplied AIR Hood

| Description | Item # |
|---|-------------|
| 88-H.P hood w/469-6 starter hose | 4507-0027 |
| 88-Free-Air hood | 4507-0017 |
| 77-1B Inner Lens each | 4510-0005 |
| 77-1-040 Outer Thick Lens each | 4510-0004 |
| 77-1-020 Thick Outer Lens each | 4510-0001 |
| 77-14 Adhesive Mylar Lens 25/pkg | 4510-0015 |
| 77-LC Perforated Mylar Lens 25/pkg | 4510-0013 |
| 77-1-0120 Rect.Outer Lens 50/pkg | 4510-0021 |
| 461040 88VX Outer Rect. .040" Lens each | 4510-0002 |
| 461B Inner Rect. .040" Lens each | 4510-0003 |
| F-35 Hood Connector to Free Air Hose | 99-095-0021 |

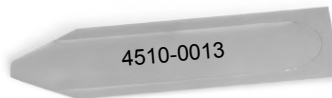

Bullard® Hood Options

| Description | Item # |
|---|-------------|
| V-20-100ST (100' 1/2" hose for free air pumps) | 99-095-0042 |
| V-20-50ST (50' 1/2" hose for free air pumps) | 99-095-0038 |
| 469-6 (25' starter 3/8" hose for H.P. systems) | 99-095-0030 |
| 545-4 (25' extension 3/8" hose used with 469-6) | 99-095-0029 |
| 545-7 (50' extension 3/8" hose used with 469-6) | 99-095-0062 |
| AC-1000: Air Conditioner for H.P. systems only. | 4502-0007 |
| HC2400: Hot-Cold control for H.P. systems only. | 99-095-0039 |

Bullard 88 series respirator hoods feature a helmet which provides the wearer with a dust free environment and protection from impact. A 6-point suspension and chin strap are integral components to properly and comfortably fit the head. Extra wide-angle window minimizes blind spots and contains twin lenses to provide face protection. All capes have a sewn-in knitted neck cuff to provide a barrier to airborne dust. Hoods are available for use with conventional compressed air breathing sources, or the Bullard Free-Air pump. **GCT includes the 469-6 25' starter hose with the H.P Model.** When outfitted correctly the system meets all OSHA requirements.

Nova-Free Air Supplied System



4509-0028

This Nova System is your number one choice Abrasive Blasting Helmet built for ultimate comfort, durable use and increased worker productivity. The complete One-Worker Blasting Helmet system provides a portable air source for one user.

System includes: Nova helmet, 3/4 HP pump, and 50' of airline hose and fittings.

| | |
|-------------------------------|-----------|
| Outer Tear Off Lens .20" 50pk | 4510-0021 |
| Inner Lens NV2018 10pk | 4510-0042 |
| Outer Lens NV2031 50pk | 4510-0043 |

Nova 3 - Compressed Air Supplied System



6001-0464

NOVA 3 Abrasive Blasting Helmet built for ultimate comfort, durable use and increased worker productivity using breathing grade compressed air. The airline filter is designed to remove oil mist, water vapor and particulates down to 0.5 microns.

System includes: NOVA 3 sandblast helmet, breathing air tube, standard 28" nylon cape, RADEX air filter, and 25' of air hose.

| | |
|--------------------------|-----------|
| Outer Tear Off Lens 50pk | 4510-0046 |
|--------------------------|-----------|

Radex Airline Filters

Airline filters can be used in conjunction with other compressor safeguards to supply cleaner air to airline respirators. The large capacity 6 stage filter cartridge removes moisture and particulates to 0.5 micron and odor from the compressed air stream, providing clean breathable air.

| Type | Item # |
|---------------------|-------------|
| Single outlet | 4509-0031 |
| Double outlet | 4502-0001 |
| Replacement Filters | 99-095-0024 |



4509-0031

Nova GX4 Gas Monitor



This system offers high quality in-line filtration for compressed air with integrated monitoring for carbon monoxide. Fitted with a 103 DBA staccato alarm as standard. This alarm can be supported with one or more options that connect to the 12 volt output.

Connect to the GX4® from your laptop, tablet, phone or via a network.

Nova Lenses

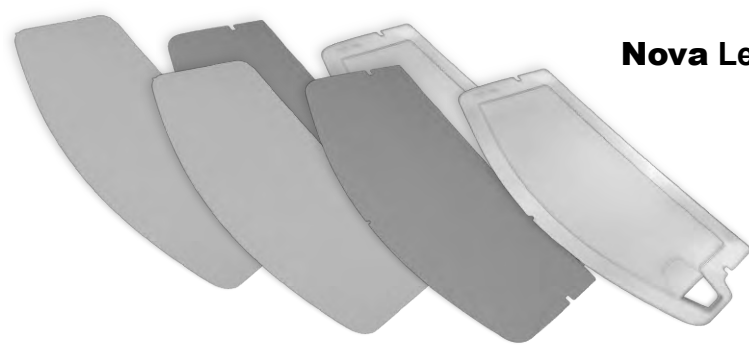

| Description | Item # |
|--|-----------|
| Nova 3 Inner Lens NV3-722 (10 pack) | 4510-0044 |
| Nova 3 Outer Lens NV3-724 (50 Pack) | 4510-0045 |
| Nova 3 Tear Off Lens NV3-725 (50 Pack) | 4510-0046 |
| Nova 2000 Tear Off Lens NV2017 (50 Pack) | 4510-0041 |
| Nova 2000 Inner Lens NV2018 (10 pack) | 4510-0042 |
| Nova 2000 Outer Lens .020 NV2031 (50 Pack) | 4510-0043 |

Nova Hot & Cool Tubes



4502-0017

99-059-0002

The Hot Air Tube Assembly warms compressed breathing air coming into respirators by as much as 30 F(17 C). The Hot Air Tube helps to maximize worker comfort and increase productivity in cold climates.

The Cold Air Tube Assembly cools compressed breathing air coming into respirators by as much as 32 F(18 C). The 4000-01 Cold Air Tube helps maximize worker comfort and increase productivity in hot climates.

Nova Air Cooling System for Free Air Pumps



4502-0019

(Includes 5' hose with couplers- Free Air pump is separate)

A low cost and portable means of cooling breathing air produced by ambient air pumps. It is capable of reducing the air temperature from 180°F (82.22°C) to as low as 50°F (10°C).

70 Quart (6624 liter) "MAXCOLD" Igloo Cooler, "Chicago Style" inlet coupler, Uses FDA Grade, 3-A sanitary standard, PVC tubing for temperature cooling coil, Single outlet coupler can adapt quickly to accept 3-worker manifold, Use with 1-, 2 -or 3-worker ambient air pumps. Weight: 28lbs, OA Height: 24", OA Length: 21", OA Width: 20"

Nova Climate Control Device for Compressed Air NOVA 3

HOT AND COLD AIR AT YOUR FINGER TIPS!



4502-0018

C40 can cool incoming air by up to 52 degrees Fahrenheit or heat it by up to 33 degrees Fahrenheit. All this is achieved by a simple switch!

Bullard® EDP-16 Free Air Pump

Supplies air to two continuous flow airline hood/helmet style respirators or three tight-fitting face piece style respirators approved to operate at 15 psig or less. Available in a hazardous-duty version. Air flow: 16 cfm at 5 psig.

- Specifications:**
- 11.5" wide • 13.5" high
 - 24" long • MSHA/NIOSH approved.

4502-0005

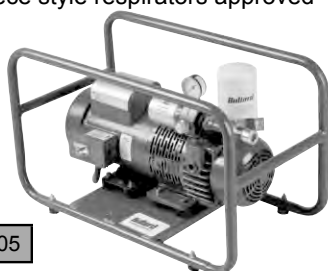

Nova EDP-16 Free Air Pump

3/4 HP electric motor and the capacity to drive 2 masks or 1 hood. Simple to use, this compressor is intended to move clean air though a hose to your breathing zone. Place the unit outside the work area (clean air), attach the hose, and plug in the quick-connect for your mask or hood.

That's it, you're ready to work!
Air flow: 0-10 CFM at 2-12 psi.

- Specifications:**
- 9" wide • 13" high
 - 16" long • UL Rec., CSA Certified

4502-0016



Bold Safety Glasses



Lenses Repel Oil, Water, & Dust

4504-0019

- Scratch Resistant Coating
- Double Injection Rubber on Temples
- Matching Rubber Nose Pads
- Hydrophobic Coating

Cool Breeze Safety Glasses



4504-0020

- Scratch Resistant Coating
- Metal Side Piece Design
- Rubber Ear Pads
- Flash Mirror Lenses

Dark lens for outdoor work!

QM24+® 3-Position Earmuff



4503-0014

- NRR 25 (M)
- Multiple position headband for over-the-head, behind-the-head, or under-the-chin wearing.
- Light weight plastic headband.

- Scratch Resistant Coating
- Fits Over Most Prescription Glasses
- Soft Airy Foam
- Double-Sided Anti-Fog Coating
- 5.5" Wide X 2" High X .75" Deep

Outfitter Safety Glasses

4504-0022

Wear over Glasses!



Back Support Belt



- All-elastic with 2-stage closure
- Detachable suspenders

| | |
|-----------|-----------|
| M 30-34" | 4501-0050 |
| L 34-36" | 4501-0051 |
| XL 36-38" | 4501-0052 |

X-Emboss Ear Plugs



4503-0009

200 Pairs

100 Pairs

- 32 dB
- End of plug reduced pressure at opening of ear, for comfort.
- Polyurethane foam

4503-0010

White Safety Cap with Ratchet Suspension

Fits Hat Size: 6-1/2 to 8

4506-0004



MOLDEX PlugStation® Earplug Dispenser



- NRR 33 (M)
- Click mechanism for easier use and dispensing.
- Chute delivers plugs into the palm of your hand.
- Eliminates the mess of individual paper/polybag packaging.
- 250 per PlugStation® with SparkPlugs®.

4503-0008

V Guard Shield Frame with Debre Control



4504-0007

Clear Shield for V Guard Poly Carb .040 Thick



4510-0010

131 Piece First Aid Kit

- Meets ANSI Z308.1-2009 standard
- Contains an assortment of practical, single-use disposable items
- Multi-use first-aid kit designed for use in the work place for up to 25 employees
- Ideal for light to medium industry, contractors and construction sites
- Able to mount to the wall
- Dimensions: Plastic case 6.5" x 7.5" x 2.75"

4511-0001



NEW Low Odor Formula!



RIVAL SOLVENT BASED Premium Impregnator

| Size | Item # |
|-----------|-----------|
| 1 Pint | 0710-9314 |
| 1 Quart | 0710-0314 |
| 1.25 Gal. | 0710-5314 |
| 55 Gallon | 0710-5514 |

This protective treatment is a highly effective premium silicone impregnator designed for use on all natural stones, and can be used on polished or unpolished surfaces.

This impregnator protects from both oil and water stains.

This product also cures quickly and looks natural.

Suitable for indoor and outdoor use.



AKEMI Stone Impregnator

Great protection of stains on all natural stone. Silicone Impregnator

| | |
|-------|-----------|
| 1 lt. | 0710-0095 |
| 5 lt. | 0710-0096 |



AKEMI NANO

Food Safe Impregnator for the ultimate protection of the stone surface. Blocks oil and water-based stains.

| | |
|-------|-----------|
| 1 lt. | 0710-0084 |
| 5 lt. | 0710-0080 |



BulletProof® Stone Sealer

Provides maximum "natural look" protection for natural stones. Formulated with water based fluoro-polymers to protect against the toughest oil and water-based stains.

| Size | Item # |
|-----------|-----------|
| Quart | 0710-0018 |
| Gallon | 0710-0017 |
| 5 Gallon | 0710-0036 |
| 55 Gallon | 0710-0043 |



Impregnator Pro® Sealer

A superior stain protector for all interior dense stone, ceramic tile, marble, limestone, granite, etc.

| Size | Item # |
|-----------|-----------|
| Pint | 0710-0012 |
| Quart | 0710-0021 |
| Gallon | 0710-0013 |
| 5 Gallon | 0710-0032 |
| 55 Gallon | 0710-0048 |



Enhancer Pro™ Sealer

A superior solvent-based color enhancing impregnator sealer with superior stain protection for all interior and exterior natural stone, tile, marble, granite, limestone, and masonry surfaces.

| Size | Item # |
|-----------|-----------|
| Pint | 0710-0023 |
| Quart | 0710-0019 |
| Gallon | 0710-0014 |
| 5 Gallon | 0710-0039 |
| 55 Gallon | 0710-0047 |



Revitalizer® Cleaner and Protector

A safe and effective neutral pH concentrated daily cleaner with protector for most natural stone, ceramic tile, etc.

| Size | Item # |
|-----------------|-----------|
| 24 OZ. Spray | 0703-0006 |
| Ready-35 Wipes | 0703-0022 |
| Gallon | 0703-0017 |
| 5 Gallon | 0703-0036 |
| Conc. 55 Gallon | 0703-0040 |



**Stone Essentials®
Stone & Tile Restore**

- Deep cleaning, professional strength
- Restores original surface beauty
- Free-rinsing
- Remove hard water mineral deposits
- Interior and exterior use

Acid-based, VOC-compliant restoration cleaner is formulated to restore ceramic and grout to their original beauty. Dissolves grout haze, efflorescence, and mineral soils. May also be used on slate, sandstone, and granite. Ready-to-use formula.

16oz Spray 0711-0012



**Stone Essentials®
Daily Cleaner with Protector**

- Deep cleaning
- Built-in stain protection
- Streak free/free-rinsing
- VOC compliant in all 50 states
- Interior and exterior use

VOC-compliant cleaner and degreaser with built-in stain protection for all stone, ceramic tile, grout, quartz and masonry surfaces.

16oz Spray 0703-0075

Granite City Stone Clean



Easy to use crystal cleaner is one of the most effective on the market for cleaning granite and for removing dirt, grime and most common stains.

1lb 0703-0001

GCT Oxalic Acid



A good, low priced crystal cleaner for cleaning soiled, grimy granite. Also used as an aid in polishing marble. Available in any quantity from 1 lb. and up.

0703-0002

Nu-Stone²



Environmentally safe and easy to use pre-mixed cleaner. Most effective on the market for cleaning granite or marble. Removes dirt, grime, oil, rust, grease and sap stains, and other discolorations which plague memorials. Can be used safely around flowers, shrubbery, grass, etc. Is harmless to the hands and is environmentally safe.

1 Gal 0703-0018



**AKEMI
Graffiti Remover**

Akemi Graffiti-Remover is a product based on highly-effective solvents which removes spray paint graffiti and the like. It is free of acids, lyes, and hydrocarbon chlorides. It is especially suited for mineral bases such as natural and artificial stone, concrete, bricks, clinker, sand lime-bricks, and plaster.

1lb 0712-0037



KLENZTONE Granite Cleaner

KLENZTONE® makes it easy to give new life to old stone. It works like no other product. Apply KLENZTONE®'s patented formula to granite and marble, and rinse off with water. KLENZTONE cleans safely without eroding the surface. It cleans polished as well as unpolished stone. When you use KLENZTONE® to clean old stone, the results are unbelievable!



1 Gal 0703-0086



Tiz Two

A very effective granite cleaning acid. Works well for removing board stains. Can be used with crystals on tough stains. Will darken light colored granites if allowed to penetrate.

1 Gal 0703-0046



D/2 Biological Solution

D/2 Biological Solution is specially formulated to remove environmental pollution, dirt, and staining from biological soils such as mold, mildew, lichen, and algae from indoor and outdoor structures.

Biodegradable, no bleach, no acid, no salts. D/2 will not harm plants, stone, animals or people.



| | |
|--------|-----------|
| 1 Gal | 0703-0068 |
| 5 Gal | 0703-0070 |
| 55 Gal | 0703-0071 |



AKEMI Oil and Grease Remover Paste

Used to remove grease, oil, wax stains and discolorations arising from plasticizers in sealants on all kinds of natural & artificial stone.

250ml 0707-0009



MP-7 Rust Remover

The best rust remover we have found. Contains acid, yet can be used safely on granite or marble. It's also very effective on concrete. 1 gal. containers only.

0703-0012



Rust Remover

Enables rust and rust stains to be removed effortlessly from acid-resistant natural and artificial stone.

| | | | |
|--------|-------------|-------|-----------|
| Paste | Surface | 250ml | 0707-0010 |
| Liquid | Penetrating | 1 lt | 0702-0069 |

Bellinzoni® Mangia Macchia Stain Remover



"Stain Eater" is a product especially formulated to remove stains on marble, granite, terracotta, terrazzo and ceramic. It eliminates most of the visible stains such as oil, industrial oil, edible oil, coffee, etc.

250ml 0711-0009

Bellinzoni® Mangia Ruggine Rust Remover



"Rust Eater" is a rust remover powder specifically designed to remove rust and rust stains from all lapideous materials (marble, granite, calcareous stones, slate terracotta & ceramics. Acid free can be used on polished marble.

20oz 4102-0015

Oil Stain Remover



A superior, citrus solvent-based poultice especially formulated for removing stubborn oil-based stains.

1 pt 0707-0002



AKEMI Marble Rust Remover

Watery, slightly alkaline cleaning agent ready-to-use. Converted rust can be removed with clean water. Can be used on polished marble, limestone, natural and artificial stone, or concrete ashlar being sensitive to acids.

500ml 0711-0015



ALPHA® Rust Gel Stain Remover

Alpha Professional Tools® leads the way with an innovative product designed to quickly remove common rust stains. In most cases, the RSR-2000 will completely remove a rust stain within 5 minutes or less.

14oz 0711-0006



K2r Spot Remover

Spray on powder. Dries & pulls oils & grease stains. Works best on fresh stains.

Simply spray the stain, then allow to dry to a white powder, finally brush away using the built-in brush.

0711-0011



Bellinzoni® Marble Poultice Powder

Safely removes surface and deep stains from polished and porous stone and masonry surfaces. Oderless and non-acidic. Will not etch or discolor marble, limestone or other acid-sensitive surfaces.

| | |
|------|-----------|
| 5lb | 0707-0013 |
| 20lb | 0707-0014 |



ALPHA® General Stain Remover & Rust Stain Remover

Alpha® General Stain Remover is an easy to use dry poultice which is very effective in removing a variety of stains. Just mix with water to form a paste and then apply over the surface of the stone. No scrubbing required so surfaces retain their original finish.

| | |
|---------------|-----------|
| "GENERAL" 5lb | 0711-0001 |
| "RUST" 5lb | 0711-0004 |



Stone Essentials® Enhance & Protect

- Superior color enhancement
- Deep-penetrating
- Preserves natural appearance
- Excellent water and oil barrier
- Interior and exterior use
- Non-yellowing/U.V. resistant

| Size | Item # |
|-------|-----------|
| Quart | 0710-0124 |

Premium solvent-based color enhancer brings out the vibrancy of natural stone, unglazed tile, grout, and masonry surfaces without leaving a sheen. Forms a vapor-permeable barrier that protects against water- and oil-based stains.



Stone Essentials® Ultimate Enhancer

- Superior color enhancement
- Deep-penetrating
- Preserves natural appearance
- Excellent water and oil barrier
- Interior and exterior use
- Non-yellowing/U.V. resistant

| Size | Item # |
|-------|-----------|
| Quart | 0710-0125 |

Color enhancer and stain protector for interior/exterior exotic natural stone, granite, marble, travertine and agglomerate surfaces. Recommended to match the color between top and edge on epoxy resin-treated stone leaving a non-glossy, transparent, UV resistant, vapor-permeable barrier to resist water and stains while enhancing the substrate with a "wet-look" appearance.



AKEMI Akemi Spider

Fill and hide micro-fissures and the spider web effect on stone surfaces

Color enhancer and fast drying.

| | | |
|-------|-------|-----------|
| 1 lt. | Clear | 0710-0092 |
| 1 lt. | Black | 0710-0093 |



AKEMI Darkener Super

Enhancer for all stone. Ages stone and edges. Interior and Exterior use

| | |
|-------|-----------|
| 1 lt. | 0710-0062 |
| 5 lt. | 0710-0076 |



AKEMI Transformer

1000ml 0710-0146

Use to match cut and ground countertop edges with highly resin treated surfaces

- Intensifies stones natural color (creates a wet look)
- Penetrates, will not leave a layer on surface
- Non-yellowing • Low odor
- Indoor and outdoor use

TREATMENT



- Black dye for black granite.

1 lt. 0706-0042

MAINTENANCE



- Black liquid wax for black granite.

1 lt. 0706-0043

Ager



0706-0008

Generally applied to sanded or smooth surfaces to give the stone a wet look.

Adria Black



Adria Black was specifically formulated to seal and enrich the color on black stones. This is a resin based formula that will fill micro fissures and add a deep gloss to enhance the depth of polish on dark stones.

1 liter 0706-0115

Ice Instant Color Enhancer



I.C.E. is a true penetrating color enhancer for all types of natural stone. I.C.E. can be used to enhance the stone where polishing tools may not be able to reach.

0706-0051



GCT Black Beauty

Formulated to brighten the color and brilliance of dark stone and aids in restoring the luster to faded black granites. Works as an impregnator to enhance the beauty and help protect black granites from the effects of acid rain. Can be used before etching for greater contrast and will aid in hiding scratches, scuffs and imperfections on polished surfaces. 1 pint container.

4102-0003



RIVAL

Heavy Duty Stone Polish

POLISHER-CLEANER-PROTECTOR

16oz | 0706-0041

- No Buildup.
- Resists water spots and stains.
- Comes in 16 oz. spray can.
- Do not use on walking surfaces.



AKEMI

Stone Polish

Cleans and renews the brilliance of polished stone. Protects from staining and is water-repellent. For interior and exterior use.

250ml | 4102-0001



RIVAL

"HIDE A SCRATCH" SYSTEM

Designed to hide scratches in stone making them virtually undetectable. Sold exclusively by Granite City Tool. Now you don't need to re-polish a stone if you find scratches after buffing or get scratches during transporting. Imagine the time and money you will save by not having to redo a job. This is a **must** for every fabricator.

| Description | Item # |
|---------------------------------|-----------|
| Super Thin - 2oz | 0302-0005 |
| Thin - 2oz | 0302-0001 |
| Medium - 2oz | 0302-0002 |
| Thick - 2oz | 0302-0003 |
| Non Green 6oz Activator Aerosol | 0304-0019 |
| Activator Spray - 2oz | 0304-0003 |
| De-Bonder - 2oz | 0304-0004 |



Apply Scratch Remover
Apply Accelerator Spray
Scratch off excess



Single Sided Razor Blades

Box of 100 #9 0305-0011

The Shaveit

A 12 razor blade scraper with plastic handle. *Use caution*

0305-0076

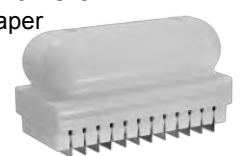

Mini Scraper

Plastic Durable Hand Scraper Easy to use snap & lock blade change Use with plastic or metal blades Includes 1 plastic razor blade

0305-0091



FillaChip Starter Kit

0702-0075

Used when a fast permanent repair is needed to fix scratches, chips, gouges, holes, cracks, and nicks on stone.

Contains: Large plastic case with foam slots, 2x UV flashlights, 4x syringes of glue containing 3cc's each syringe, 10x needle dispensing tips, & 8x plastic release sheets



FillaChip Refill Kit

0702-0076

Contains: Cardboard refill box, 4x syringes of glue containing 3cc's each syringe, 10x needle dispensing tips, & 8x plastic release sheets



FillaChip Precolored

Contains: 1x syringe of colored glue containing 3 cc's, & 1x syringe of polish containing 3 cc's

| Description | Item # |
|--------------|-----------|
| Trans. White | 0702-0084 |
| Super White | 0702-0085 |
| Trans. Black | 0702-0086 |
| Super Black | 0702-0087 |
| Grey Vein | 0702-0088 |
| Concrete | 0702-0089 |
| Uba Tuba | 0702-0090 |

*These colors are an addition! add on to the Starter Kit

Natural Stone Repair Kit

- Crack repairs
- Countertop repairs
- Floor & tile restoration
- Seaming
- Fast Setting: 20 minutes
- UV stable
- Patch holds up through severe climate changes

0301-0330

Kit Includes:

- Last Patch Gel - 1 kit
- Last Patch Accelerator - .5 oz
- 15 Mix sticks
- 10 Razor blades
- Assorted liquid tints:
 - Black, White, Buff, Brown,
 - Green, Rust, Blue, Yellow



Monument Repair Kit

- Hide Scratches
- Patching
- Chip & crack repair
- Fix broken or spalled stone

0301-0689

Kit Includes:

- 1- Last Patch Dymond 2oz kit
- 1- Last Patch Gel 2oz kit
- CA Glue Super Thin
- CA Glue Gel
- CA Glue Activator
- Flits Polish
- Mix Sticks(Mini)
- Mix Cups(Mini)
- Gray Granite Dust
- Black Granite Dust
- Red Granite Dust
- Pink Granite dust
- White Marble Dust



- White Quartz Dust
- Brown Stone Dust
- Liquid Tints(8 colors)
- Last patch Limestone Accelerator
- Razor Blades

Powder Tints are available in the following 7 colors:

| Color | Item # |
|--------|-----------|
| Yellow | 0301-0129 |
| Gray | 0301-0130 |
| Black | 0301-0131 |
| White | 0301-0132 |
| Rust | 0301-0133 |
| Green | 0301-0134 |
| Brown | 0301-0135 |



Stone Dust is available in the following 7 colors:

| Color | Item # |
|---------------|-----------|
| Grey Granite | 0301-0122 |
| Red Granite | 0301-0123 |
| Brown Granite | 0301-0124 |
| Pink Granite | 0301-0125 |
| White Quartz | 0301-0126 |
| White Marble | 0301-0127 |
| Black Granite | 0301-0128 |



Last Patch™ Dymond

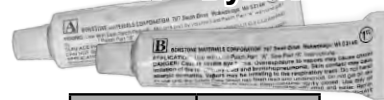

Tubes A & B 0301-0684

Catalyst

For even faster set time, use our Accelerator. Accelerator is not recommended for work over 85°F.

1/2 oz 0301-0141



Last Patch™ Limestone
Mix Ratio = 7:1

Set Time:
15 Min @ 75°

| | | |
|-------|---------------|-----------|
| Buff | 1Qt A - 4oz B | 0301-0093 |
| Gray | 1Qt A - 4oz B | 0301-0460 |
| Cream | 1Qt A - 4oz B | 0301-0676 |



Last Patch™ Dymond
Mix Ratio = 1:1

Set Time:
10-20 Min @ 75°

| | |
|----------------|-----------|
| 1oz A - 1oz B | 0301-0684 |
| 1Pt A - 15oz B | 0301-0470 |
| 1Qt A - 30oz B | 0301-0471 |

Patching compound for limestone or sandstone camouflages its patchwork by absorbing water just like the porous stone surrounding it. Use when you need less noticeable repairs on porous stone.

An exterior grade, UV stable stone repair compound for granite, marble, travertine and any other highly polished natural stone surface.



TOUCHSTONE™ Glacier

Set Time:
10-20 Min @ 75°

- Clear
- Laminating adhesive, especially white stones such as marble
- Seaming adhesive
- Interior & exterior
- Set Time: 10-20 min @ 75°
- Pot Life: 5-10 min @ 75°

| | |
|----------------|-----------|
| 1oz A - 1oz B | 0301-0542 |
| ½Pt A - 7oz B | 0301-0472 |
| 1Qt A - 30oz B | 0301-0473 |

| | | |
|-------------|-------------|-----------|
| White Color | 250ml Cart. | 0301-0543 |
| | Mixer Nozz. | 0305-0025 |



New EZ Flow Spout



RIVAL PREMIUM Polyester Resin Products

**Work 4-6min
Cure 30min**

- ◆ Strong bonding strength and quick cure time.
- ◆ Perfect for seaming, or rodding.
- ◆ Accepts resin coloring paste to match stone.
- ◆ For indoor use only.

Made in U.S.A.

| Desc. | Item # |
|----------------------------------|-----------|
| Transparent Flowing - Quart | 0303-0092 |
| Transparent Flowing - Gallon | 0303-0093 |
| Transparent Flowing - 5 Gal | 0303-0094 |
| Transparent Knife Grade - Quart | 0303-0095 |
| Transparent Knife Grade - Gallon | 0303-0096 |
| Transparent Knife Grade - 5 Gal | 0303-0097 |

Extra Hardeners

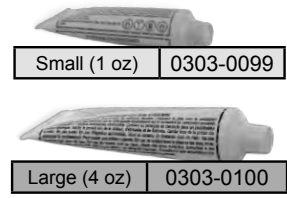

| | |
|--------------|-----------|
| Small (1 oz) | 0303-0099 |
| Large (4 oz) | 0303-0100 |

E-Z Flow Pourable Lid



Works on 1 gallon and 1.25 gallon cans

0305-0074

RIVAL THE BIG BOX



Individual cans reduce contamination compared to a open 5 or 2.5 gallon pail.

**Work 4-6min
Cure 30min**

| Desc. | Item # |
|-----------------------------------|-----------|
| Transparent Flowing - BIG BOX | 0303-0163 |
| Transparent Knife Grade - BIG BOX | 0303-0164 |

Can be shipped via UPS or FedEx without costly hazardous fees!

RIVAL 2-PAK



**Work 4-6min
Cure 30min**

| Desc. | Item # |
|--------------------------------|-----------|
| Transparent Flowing - 2 PK | 0303-0161 |
| Transparent Knife Grade - 2 PK | 0303-0162 |

AKEMI 1000 Polyester Transparent Resin

The "original" polyester stone adhesive.
The best, most consistent brand in the market still today.

- Excellently polishable
- Very good adhesion on natural stone
- Resistant to water, petrol and mineral oils

| Size | Desc. | Item # |
|---------|--------------------------|-----------|
| 900 ml | 1000 Transparent Flowing | 0303-0018 |
| 4500 ml | 1000 Transparent Flowing | 0303-0027 |
| 900 ml | 1000 TRANS Knife Grade | 0303-0022 |
| 4500 ml | 1000 TRANS Knife Grade | 0303-0059 |

Extra Hardeners

| | |
|--------------------|-----------|
| Small (20G) Liquid | 0303-0004 |
| Small (30G) Paste | 0303-0003 |
| Large (150G) Paste | 0303-0014 |



RIVAL

White Polyester

Colored to match white stones and will not change color during the curing process! Non-sagging formula allows usage for vertical and horizontal applications.



Knife Grade

Work 4-6min
Cure 30min

Qt. 0303-0138

Extra Hardener Small (1 oz) 0303-0099

RIVAL

Water Clear Polyester

- Ideal for seaming & repairing natural stone surfaces.
- Perfect for use on vertical or horizontal surfaces.
- Accepts resin coloring paste to match stone.
- For indoor use only.



Knife Grade

Work 10-20min
Cure 2-4hours

Qt. 0303-0137

Extra Hardener Small (.5oz) Liquid 0303-0158

RIVAL

Water Clear Polyester

- Ideal for bonding & filling on horizontal natural stone surfaces
- Accepts coloring paste for matching stone
- Ideal for use on light colored stone
- UV stable & weather resistant.



Flowing

Work 10-20min
Cure 2-4hours

Qt. 0303-0136

Extra Hardener Small (.5oz) Liquid 0303-0158

AKEMI

1000 Platinum Adhesives

Epoxyacrylate formulation. Very clear and 50% stronger than standard Akemi polyesters.



Work 5-15min
Cure 15-40min

| Size | Desc. | Item # |
|--------|----------------------|-----------|
| 900 ml | Platinum Flowing | 0303-0089 |
| 900 ml | Platinum Knife Grade | 0303-0023 |

Extra Hardener Small (30G) Paste 0303-0003

AKEMI

1000 Polyester Water Clear Resin

For filling, seaming and repairing light colored stones. Stays clear in UV light.



Work 12-20min
Cure 12hours

| Size | Desc. | Item # |
|--------|-------------------------|-----------|
| 900 ml | Flowing Translucent | 0303-0020 |
| 900 ml | Knife Grade Translucent | 0303-0074 |

Extra Hardener Small (20G) Liquid 0303-0004

RIVAL

Travertine Filler

Qt. 0303-0106

- Ideal for filling, bonding & repairing travertine and other porous stones.
- Tinted adhesive matches the color of most travertine stone.
- Accepts resin coloring paste to match stone.
- For indoor use only.



Knife Grade

Work 4-6min
Cure 30min

Extra Hardener Small (1 oz) 0303-0099

AKEMI

1000 Light Ivory Travertine

1000 ml 0301-0326

Soft and smoother consistency for filling and repairing Travertine. Easily model corners and edges.



Knife Grade

Work 5-7min
Cure 20-30min

Adria

Travertine Filler

Lt. 0303-0257

Works great for repairing travertine and other porous stones. Very easy to apply and can fill up to 1/2" holes



Knife Grade

Work 3-5min
Cure 10-20min

AKEMI

1000 Polyester Buff Marble Filler

1000 ml 0303-0130

For gluing and filling natural and cast stone. Works for vertical surfaces, excellent surface hardening.



Knife Grade

Work 5-7min
Cure 20-30min

Superior Gold Acrylic Epoxy

PRODUCT FEATURES:

- Strong enough to withstand the added pressure of CNC or automatic edge machines.
- Cutting edge resin technology that outperforms epoxy systems.
- Great for laminating, bonding and rodding. High polishability.
- Exhibits excellent mechanical and chemical bonding.
- Very low in color. Ideal for perfect color matching.
- For INDOOR and OUTDOOR applications.
- Excellent UV stability.

GOLD is a revolutionary new adhesive for natural stone, quartz surface and solid surface materials. Extremely fast cure time ("Tack Free" in less than 20 minutes at room temperature) and easy to use with no difficult mixing ratios or special dispensers required.



Work 7-9min
Cure 20min

| Desc. | Item # |
|------------------------------|-----------|
| Flowing - Quart | 0303-0198 |
| Flowing - Gallon | 0303-0199 |
| Flowing - - BIG BOX (5gal) | 0303-0217 |
| Knife Grade - Quart | 0303-0218 |
| Knife Grade - Gallon | 0303-0219 |
| Knife Grade - BIG BOX (5gal) | 0303-0220 |

Superior Poly-Epoxy

Poly-Epoxy adhesives combine our Polyester and Epoxy resin technology providing the strongest bond available in a polyester formula. Great for seaming and laminating all stone types including dense granite. Poly-Epoxy uses the same white paste hardener (BPO) as our Polyesters and Acrylics. Poly-Epoxy has a gel time of 4-6 minutes. An excellent choice for indoor applications.

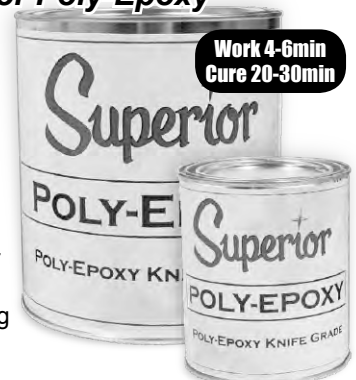

Work 4-6min
Cure 20-30min

| Desc. | Item # |
|----------------------|-----------|
| Knife Grade - Quart | 0303-0177 |
| Knife Grade - Gallon | 0303-0178 |

AKEMI Everclear Resin

Flowing: For filling of holes and fissures as well as surface improvement of natural stones. For horizontal stone bonding.

Knife Grade: For bonding and filling of natural and artificial stones as well as paper, wood, glass, metal and certain plastics. For horizontal and vertical applications.

Work 10min
Cure 12-16hours



Tintable

2 Part System, interior use: zero yellowing, exterior use: nearly no yellowing, no bleeding of treated stone, free of solvents.

Akemi highly recommends a digital scale to get the 5:4 mix ratio correct.



| Desc. | Item # |
|----------------------------------|-----------|
| Flowing 900 grams 5:4 ratio | 0303-0223 |
| Knife Grade 1350 grams 5:4 ratio | 0303-0224 |
| Digital Scale | 0305-0069 |

TOUCHSTONE™ Glacier

Set Time:
10-20 Min @ 75°

- Clear
- Laminating adhesive, especially white stones such as marble
- Seaming adhesive
- Interior & exterior
- Set Time: 10-20 min @ 75°
- Pot Life: 5-10 min @ 75°



| | |
|----------------|-----------|
| 1oz A - 1oz B | 0301-0542 |
| ½Pt A - 7oz B | 0301-0472 |
| 1Qt A - 30oz B | 0301-0473 |

| | | |
|-------------|-------------|-----------|
| White Color | 250ml Cart. | 0301-0543 |
| | Mixer Nozz. | 0305-0025 |

Superior Pearl Resin

Very light / white (pearlescent) color making it ideal for invisible joints especially on light colored stones. Perfect for seaming, laminating and chip repair on all types of natural stone including dense granite.

An excellent choice for indoor applications

Cutting edge resin tech. formulated to provide stronger bonds than polyester adhesives. Working time 3-5 minutes. Full, tack-free, cure in less than 20 minutes. Light color makes it easy to add Coloring Paste for perfect color matching

| Desc. | Item # |
|---------------------------|-----------|
| Full Knife Grade - Quart | 0303-0228 |
| Full Knife Grade - Gallon | 0303-0229 |



Work 3-5min
Cure 20min

AKEMI Akepox Adhesives

All Akepox Epoxies can bond to damp stone and are resistant to alkaline environments / weather resistant.



| Size | Desc. | Item # |
|---------|------------------------------|-----------|
| 1.25 kg | 1005 Clear Penetrating | 0301-0261 |
| 2.25 kg | 2010 Light Trans Knife Grade | 0301-0052 |
| 750 g | 2040 Grey Knife Grade | 0301-0054 |
| 1.50 kg | 5000 Clear Flowing | 0301-0116 |
| 2.25 kg | 5010 Clear Knife Grade | 0301-0316 |

**Work 20-30min
Cure 24hours**

Akepox 1005:
Highly penetrating low viscosity transparent/pale formula, increases firmness and quality of stone, solvent free, weather resistant

**Work 20-30min
Cure 6-8hours**

Akepox 2010:
A gel-like transparent honey yellow knife grade for high strength bonding of stone and load bearing construction parts, light transparent color, extreme weather resistance.

**Work 45-55min
Cure 6-8hours**

Akepox 2040:
Light Grey Knife Grade epoxy that can bond stone to stone and stone to metal (steel, alum., etc)

**Work 20-30min
Cure 16-18hours**

Akepox 5000:
Transparent crystal clear flowing epoxy formula, flowing version of 5010

**Work 20-30min
Cure 16-18hours**

Akepox 5010:
Best Selling Akemi Epoxy. Transparent Milky white knife grade clear epoxy formula. Very low color change outside.

RIVAL

Water Clear Flowing Epoxy 2A:1B

| | |
|--------|-----------|
| 3 Qt. | 0303-0192 |
| 3 Gal. | 0303-0193 |



Flowing

**Work 10-20min
Cure 4-8hours**

- Very low viscosity with high penetration.
- For consolidating stone or repairing fine cracks or fissures.
- For indoor and outdoor use.

RIVAL

Water Clear Knife Grade Epoxy 2A:1B

| | |
|--------|-----------|
| 3 Qt. | 0303-0194 |
| 3 Gal. | 0303-0195 |



Knife Grade

**Work 10-20min
Cure 4-8hours**

- Ideal for external applications.
- Bonds natural stone on vertical surfaces.
- Ideal for light colored stones.
- For indoor and outdoor use.

RIVAL Colorants

| Color | 2 oz. | 8 oz. |
|-----------|-----------|-----------|
| Buff | 0303-0233 | 0303-0175 |
| Gray | 0303-0234 | 0303-0176 |
| Ochre | 0303-0235 | 0303-0174 |
| Black | 0303-0236 | 0303-0167 |
| Red-Brown | 0303-0237 | 0303-0170 |
| Green | 0303-0238 | 0303-0171 |
| Brown | 0303-0239 | 0303-0173 |
| Blue | 0303-0240 | 0303-0172 |
| Red | 0303-0241 | 0303-0169 |
| White | 0303-0242 | 0303-0168 |



10 Color (2oz) Kit
0303-0232



TOUCHSTONE™

Colorants

| Color | 2 oz. | 8 oz. |
|-----------|-----------|-----------|
| White | 0301-0082 | 0301-0115 |
| Black | 0301-0083 | 0301-0099 |
| Red | 0301-0084 | 0301-0159 |
| Red-Brown | 0301-0085 | 0301-0114 |
| Blue | 0301-0086 | 0301-0160 |
| Yellow | 0301-0087 | 0301-0161 |
| Brown | 0301-0088 | 0301-0110 |
| Buff | 0301-0089 | 0301-0111 |
| Gray | 0301-0090 | 0301-0112 |
| Green | 0301-0091 | 0301-0113 |



10 Color (2oz) Kit
0301-0092

Resin & Epoxy Coloring Pastes

AKEMI Color Paste Resin Colors

| Color | 1 oz. | Color | 1 oz. |
|------------------------------------|-----------|-------|-----------|
| Red | 0303-0005 | Ochre | 0303-0009 |
| Red-Brown | 0303-0006 | Green | 0303-0010 |
| White | 0303-0007 | Brown | 0303-0011 |
| Black | 0303-0008 | Blue | 0303-0012 |
| 8 Color (1oz) Kit 0303-0024 | | | |



AKEMI Color Paste Epoxy Colors

| Color | 1 oz. | Color | 1 oz. |
|------------------------------------|-----------|-------|-----------|
| Red | 0301-0003 | Ochre | 0301-0007 |
| Red-Brown | 0301-0010 | Green | 0301-0008 |
| White | 0301-0005 | Brown | 0301-0004 |
| Black | 0301-0006 | Blue | 0301-0009 |
| 8 Color (1oz) Kit 0301-0042 | | | |





Caulking Guns on Page 111 >

Domo10



Work Life: 120-150min

Used for marble, granite, and stones of all types that need to be glued and reconstructed for a permanent bond at low outdoor and indoor temperatures. Hardens in 12 hours. Sticks to wet surfaces. White.

| | |
|-------------|-----------|
| 2 Liter Set | 0301-0043 |
|-------------|-----------|

Instant Install 29



Easy 1:1 Mix Ratio!

Made in U.S.A.

14min to apply,
15min its dry!
29min Install!

The fastest, strongest, and easiest granite countertop seaming and quick tile repair epoxy for the professional or the DIY'er

| | |
|-------------------------|-----------|
| Knife Grade - 20oz. Kit | 0301-0433 |
| Knife Grade - Qt. Kit | 0301-0434 |

HRM - Historic Restoration Mortar



HRM™ Historic Restoration Mortar from Bonstone is a two-component, lime-based, latex modified mortar for the restoration of historic masonry structures.

5 lbs of powder with 2 lbs of liquid binder

| | |
|---------|-----------|
| 7lb Kit | 0301-0393 |
|---------|-----------|

RIVAL™ Transparent Epoxy 1A:1B



Flowing

Work 4-16min
Cure 2-4hours

Knife Grade

A 1:1 mix ratio epoxy with fast thin film curing and very low color. Best suited for granite laminations, this flowing adhesive is easier to mix than conventional 2:1 systems.

| Size | Desc. | Item # |
|-------|-------------------------|-----------|
| 2 Gal | Transparent Flowing | 0303-0215 |
| 2 Gal | Transparent Knife Grade | 0303-0154 |

**BONSTONE™
Fast-Set™ 41
Epoxy**



Set Time:
15 Min @ 75°

- Cures at below-freezing temperatures
- Very fast setting
- Exceptional strength and durability
- Set Time: 15 min @ 75°
- Pot Life: 10 min @ 75°

| | Product | Item# |
|-------|------------------|-----------|
| Cream | 1Qt A - 1Qt B | 0301-0100 |
| Buff | 1Qt A - 1Qt B | 0301-0180 |
| Gray | 1Qt A - 1Qt B | 0301-0181 |
| Cream | 1Gal A - 1Gal B | 0301-0686 |
| Buff | 1Gal A - 1Gal B | 0301-0544 |
| Gray | 1Gal A - 1Gal B | 0301-0685 |
| Buff | Dual 600ml Cart. | 0305-0007 |
| | Long Mix Nozzle | 0305-0008 |



Ultimate Epoxy

Set Time:
20 Min @ 75°

- True structural strength (equal to a high-quality epoxy adhesives)
- True uv-stability - non-yellowing
- Extremely fast cure
- Will cure in cold temperatures
- Buff Color
- Odor-free

| Product | Item# |
|--------------------|-----------|
| Single 180ml Cart. | 0301-0683 |
| ProTip Mix Nozzle | 0305-0025 |



**Fast-Set™ Extreme
Epoxy**

Set Time:
15 Min @ 75°

- Cures at below-freezing temperatures
- Very fast setting
- Structural bonding & repair
- Exceptional strength and durability
- Knife grade (non-sag) viscosity
- Moisture tolerant
- High modulus
- Set Time: 15 min @ 75°
- Pot Life: 15 min @ 75°

| Product | Item# |
|---------------------|-----------|
| Dual 50ml Cart. | 0301-0331 |
| Single 250ml Cart. | 0301-0271 |
| ProTip Mix Nozzle | 0305-0025 |
| 1 Gal (A) 1 Gal (B) | 0301-0302 |



Not recommended for interior application-strong odor when applying.



TOUCHSTONE™ Express II Flowing Epoxy

- Excellent for rodding counters
- Stone lamination
- Laminating stone to other construction materials
- Set Time: 30 min @ 75°
- Pot Life: 5 min @ 75°



Set Time:
30 min @ 75°

| | |
|----------------------|-----------|
| 2 Qts (A), 1 Qt (B) | 0301-0276 |
| 2 Gal (A), 1 Gal (B) | 0301-0274 |

Caulking Guns on Page 111 >

Clear Gel Knife Grade Epoxy

- Excellent for rodding counters
- Stone lamination
- Laminating stone to other construction materials
- Stone patching, repairing & bonding
- Set Time: 2 hours @ 75°
- Pot Life: 15 min @ 75°



Set Time:
2 Hours @ 75°

| | |
|-------------------|-----------|
| 180ml Cartridge | 0301-0298 |
| ProTip Mix Nozzle | 0305-0025 |
| 450ml Cartridge | 0301-0142 |
| Long Mix Nozzle | 0305-0008 |

| | |
|----------------------|-----------|
| 2 Qts (A), 1Qt (B) | 0301-0079 |
| 2 Gals (A), 1Gal (B) | 0301-0077 |



TOUCHSTONE™ Penetrating Epoxy

- Used to strengthen stone
- Can be used around bowl cut outs for added strength
- Very low viscosity (250 centipoise) gives good penetration
- Pot Life: 40 min @ 75°



Set Time:
6-8 hrs @ 75°

| | |
|---------------------|-----------|
| 2 Qts (A) 1 Qt (B) | 0301-0080 |
| 2 Gal (A) 1 Gal (B) | 0301-0146 |



TOUCHSTONE™ Penetrating Epoxy RS (Rapid Set)

- Use with scrim mesh for added strength
- Can be used around bowl cut outs for added strength
- Low viscosity (700 centipoise) gives good penetration
- Pot Life: 12 min @ 75°



Set Time:
1-2 hrs @ 75°

| | |
|----------------------|-----------|
| 2 Qts (A), 1 Qt (B) | 0301-0081 |
| 2 Gal (A), 1 Gal (B) | 0301-0119 |



TOUCHSTONE™ Edge System Clear Flowing (TES)

- Stone lamination
- Laminating stone to other construction materials
- Excellent for rodding countertops
- Set Time: 2 hours @ 75°
- Pot Life: 25 min @ 75°



Set Time:
2 Hours @ 75°

| | |
|----------------------|-----------|
| 2 Qts (A), 1Qt (B) | 0301-0076 |
| 2 Gals (A), 1Gal (B) | 0301-0075 |

| | | | |
|-----------|-----------|-----------|-----------|
| 1 Qt. (A) | 0301-0121 | 1 Gal (A) | 0301-0120 |
| 1 Qt. (B) | 0301-0118 | 1 Gal (B) | 0301-0117 |

Easy Mixing Dispensers

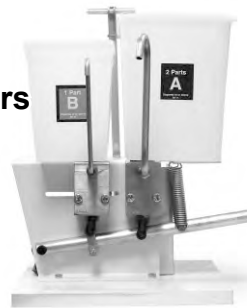

Mixer is great for fabrication shops and contractors to get the exact 2 to 1 mix and 1 to 1 mix ratios the first time!

| | |
|-----------------|-----------|
| 2:1 Dispenser | 0305-0065 |
| 1:1 Dispenser | 0305-0063 |
| Optional Heater | 0305-0064 |



TOUCHSTONE™ Fuzion



Set Time:
2 Hours @ 75°

- Economical
- Laminating stone to other construction materials
- Rodding and seaming of countertops
- Set Time: 2 hours @ 75°
- Pot Life: 10-15 min @ 75°

| | |
|----------------------|-----------|
| 2 Gals (A), 1Gal (B) | 0301-0474 |
|----------------------|-----------|

BONSTONE™ DUROPOXI Knife Grade

- Bonding concrete, masonry & stone.
- Laminating stone to other construction materials.
- For horizontal or vertical surfaces.
- Structural patching concrete.
- Set Time: 1 hour @ 75°
- Pot Life: 20 min @ 75°



Set Time:
1 Hours @ 75°

| | |
|---------------------|-----------|
| 1 Qts (A) 1 Qt (B) | 0301-0347 |
| 1 Gal (A) 1 Gal (B) | 0301-0319 |



BONSTONE™ DUROPOXI F Knife Grade

- Bonding concrete, masonry & stone.
- Laminating stone to other construction materials.
- Remains flexible after cured.
- Structural patching concrete.
- Set Time: 2 hour @ 75°
- Pot Life: 15-30 min @ 75°



Set Time:
2 Hours @ 75°

| | |
|---------------------|-----------|
| 1 Gal (A) 1 Gal (B) | 0301-0678 |
| 3 Gal (A) 3 Gal (B) | 0301-0677 |

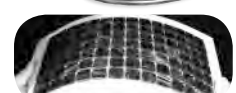

Sullivan Palatek®

Rotary Screw Air Compressors

Palatek Compressor Features:

- Air Cooled After Cooler
- Timed Dual Controls
- Full Voltage Starter
- Heavy-Duty Air Filter
- Inlet Modulation Control
- Deluxe Gauge Panel
- Protective Shutdown Features
- **5 Year Warranty**



CALL FOR
COMPETITIVE PRICING
1-800-328-7094

- Knowledgeable Sales Staff
- Full Service Department
- Warranty Service Center
- Air Drying Systems

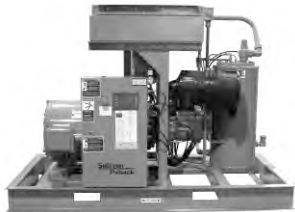
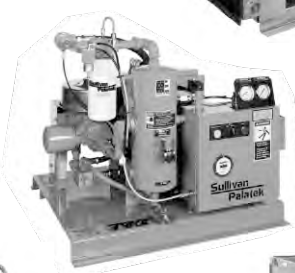

| Model | Capacity AFCM | Max Full Load PSIG | Min. Full Load PSIG | Motor H.P. | Motor Speed |
|---------|------------------|-----------------------------|------------------------------|---------------|----------------|
| 5 hp | 20 | 125 | 60 | 5 | 1,725 RPM |
| 7.5 hp | 28 | 125 | 60 | 7.5 | 3,450 RPM |
| 10 hp | 40 | 125 | 60 | 10 | 3,450 RPM |
| 15 D | 55 | 120 | 60 | 15 | 1,750 RPM |
| 20 D | 80 | 120 | 60 | 20 | 1,750 RPM |
| 25 D | 95 | 120 | 60 | 25 | 1,775 RPM |
| 25 D4 | 110 | 120 | 60 | 25 | 3,545 RPM |
| 30 D7 | 115 | 120 | 60 | 30 | 3,545 RPM |
| 40 D | 166 | 120 | 60 | 40 | 3,545 RPM |
| 75 UDG | 356 | 115 | 70 | 75 | 1,775 RPM |
| 100 UDG | 440 | 115 | 70 | 100 | 1,775 RPM |
| 125 H | 555 | 115 | 70 | 125 | 1,785 RPM |
| 150 H | 720 | 115 | 70 | 150 | 1,785 RPM |
| 200 H | 900 | 115 | 70 | 200 | 1,785 RPM |

THE ULTIMATE PERFORMANCE ROTARY SCREW AIR COMPRESSOR
5 YEAR WARRANTY* - BEST IN THE INDUSTRY! *Call for details.

CHAMPION® Air Compressors

A Gardner Denver Product



1 Year Limited
Warranty

5 Year Warranty
on Tank,
Pump & Motors

0902-



Industrial Air Receivers

Vertical & Horizontal tanks with or without platforms, for replacement or remote installations. ASME welded and approved to 200 lbs. working pressure.
Call for other sizes.



| Size | Gal. Cap. | Item # |
|-----------|-----------|-----------|
| 16" x 38" | 30 Horz. | 0907-0006 |
| 30" x 45" | 120 Vert. | 0907-0013 |
| 30" x 72" | 200 Vert. | 0907-0011 |

These self-contained air compressors are designed and built for long service life on continuous duty in manufacturing and service applications. Output selection of two stage compressors from 5.3 to 120 cfm. actual free air delivery. Available sizes- 1-1/2 to 30 hp.- tank, and base plate mounts. Replacement compressor pumps also available. *Contact us for a complete listing.



Sullivan Palatek®

Portable Air Compressors

CALL FOR COMPETITIVE PRICING

1-800-328-7094

Diesel Driven Rotary Screw Air Compressors range from 185-1800 CFM. Pressures from 100-150 PSI are available in most models. John Deere and Caterpillar diesel engines are available in most models. Skid mounted, utility and portable models available. Sullivan-Palatek also makes a complete line of off shore diesel compressors with special skid mounting and "off shore" compliant. All sheet metal used on our portable air compressors is galvaneal for protection against rust and corrosion.

Type: Single Stage, oil flooded rotary screw
 Ambient Temp. -20° to +125°F
 Oil Cap. 5.5 gal
 Air service con. 2 3/4" NPT
 Oil to air cooling
 Two stage dry air intake
 0-100% demand control
 Diesel, John Deere motors

**Contact us for a complete listing.*

| Model | Rated Delivery | Operating Pressure Range | Motor Speed |
|--------|-----------------------------------|--------------------------|-------------|
| D185Q | 185 cfm (5.2 m ³ /min) | 70-125 psig | 2,650 RPM |
| D185QH | 185 cfm (5.2 m ³ /min) | 70-165 psig | 2,500 RPM |
| D210Q | 210 cfm (5.9 m ³ /min) | 70-125 psig | 2,500 RPM |
| D210QH | 210 cfm (5.9 m ³ /min) | 70-125 psig | 2,500 RPM |
| D250Q | 250 cfm (7.1 m ³ /min) | 70-125 psig | 2,400 RPM |

Sullivan Palatek

Refrigerated Air Dryers



Models available from 12 CFM to 2650 CFM

Each Sullivan-Palatek Refrigerated Air Dryer is manufactured to the highest quality standard. Sullivan-Palatek utilized only environmentally friendly refrigerants. Our SPRF series is listed by CSA International as certified. This applies to both the Canadian and US Markets.

A modulating thermostatic expansion valve gives a more effective refrigeration control over a wide span of operating conditions, preventing compressor failure due to liquid return commonly found in capillary tube designs

Check online for more information on this product.

Sullivan Palatek

D90PKU



**Tow behind – 90 CFM Compressor
 Tier 4 Final, Free Air Delivery**

0902-0142

Specifications:

CFM: 90 cfm (2.5 m³/min)
 Rated Pressure: 100 psig (6.9 Bar)
 Max Sound Power Level 74 dBA
 Engine Make: Kubota
 Engine Model: D1105 (Tier 4 Final)
 Engine Type: Diesel-24.3 HP
 Weight: 1256 lbs
 Fuel Capacity: 6.5 gal (24 L)

Standard Features:

- Hinged canopy with gas springs for service access
- Torsion bar suspension for stable towing
- 14" wheels
- Full adjustable height draw bar, 3" eye
- Full shift fuel tank

VAN AIR Pro 35 Reciprocating Compressor



Honda or Kohler engines available
 Air power to 35 cfm with up to 170 psi
 Electric start
 Available in skid, and 30-gal. tank configuration.

| | |
|--------|-----------|
| Kohler | 0902-0101 |
| Honda | 0902-0128 |

Vanair's new line of entry level reciprocating compressor packages were developed to meet the demands of customers that need the convenience of mobile air at an economical cost.

VAN AIR Viper Gas 80 Rotary Screw Air Compressor



- 80 cfm rated delivery
- 25HP Kohler 4-cycle Engine
- 100 psig operating Pressure rating
- Single stage oil flooded rotary screw
- Oil to air cooling system
- 42" L x 33" W x 29.5" H

0902-0017

BOSS Bullet 70 Rotary Screw Air Compressor



- 70 cfm rated delivery
- 25HP Kohler 4-cycle Engine
- 100 psig operating Pressure rating
- Single stage oil flooded rotary screw
- 80-115 psig operating Pressure range
- -20° to +105°F ambient operating temp. range
- Oil to air cooling system
- 45" L x 20" W x 30" H
- 400 lbs dry weight

0902-0093

Optional Wheel Kit

0901-0136

Extractors / Dryers

MOISTURE PROBLEMS? **THE SOLUTION!**



PLEASE CALL FOR MORE INFORMATION & PRICES!

Models range from 15 SCFM thru 2,000 SCFM. Standard 5 micron ratings (lower micron rating available) Removes 99.9% of the liquids entering the Extractor/Dryer. The patented Extractor/Dryer is a two-stage, point-of-use compressed air filter. Designed primarily for the final usage of air, it will remove water, oil and other contaminants from compressed air lines.

Load Genie - Mark II



The Mark II Unloader can be universally applied to compressors for continuous run applications. Converts automatic start-stop compressors to continuous run. Pressure range and differential can be adjusted for specific need. Available in LGM-20T for up to 20 cfm.

LGM-20T 0906-0074

Air Gauges

| Size | Item # |
|------------------------------------|-----------|
| 1-1/2" Dia. 1/8" Back Mnt - 160psi | 0906-0195 |
| 2" Dia. 1/4" Back Mnt - 160psi | 0906-0154 |
| 2" Dia. 1/4" Back Mnt - 200psi | 0906-0010 |
| 2" Dia. 1/4" Lower Mnt - 0-200psi | 0906-0015 |



These gauges monitor any type of compressed air equipment. Available in 1-1/2" thru 4" diameter. Pressure readings from 0 to 200 psi., 1/8" or 1/4" bottom or back mount.

Filters



| | | |
|-------------|------|-----------|
| Mini Filter | 1/4" | 0906-0067 |
| Filter | 1/4" | 0906-0097 |
| Filter | 3/8" | 0906-0062 |
| Filter | 1/2" | 0906-0099 |
| Filter | 3/4" | 0906-0100 |
| Filter | 1" | 0904-0089 |

Filter removes contaminants and moisture. Manual drain allows easy draining with slight push on drain.

Call for other sizes.

Lubricators



| | |
|------|-----------|
| 1/4" | 0906-0199 |
| 3/8" | 0906-0101 |
| 1/2" | 0906-0102 |
| 3/4" | 0906-0103 |

Lubricator has needle adjustment to meter flow of oil. Can be filled under pressure. Clear shatter-proof bowl in all but 3/4" size, which has metal bowl with sight glass.

Call for other sizes.

Regulators



Regulator is adjustable from 0 to 125 lbs. with quick response

and accurate pressure regulation. Self-relieving, to allow pressure adjustment without air flow.

Call for other sizes.

| | |
|------|-----------|
| 1/4" | 0906-0104 |
| 3/8" | 0906-0124 |
| 1/2" | 0906-0106 |
| 3/4" | 0906-0126 |
| 1" | 0906-0086 |

EAD-25-1/4 Electronic Automatic Drain Valve



Drainage cycles can be set from 1 to 45 minutes and discharge times can be adjusted from 1 to 15 seconds. 129 Volt AC with LED indicators and manual override. 6 ft. power cord.

0906-0112

360/01-1/4 Strainer Ball Valve Combination



This unique strainer/filter protects solenoid valve. Features 40 micron screen, 300 psig. operating pressure with 1/2" MPT top connection and 1/4" MPT side (valve) connection.

0906-0113

Filter/Regulator Combo



Filter removes contaminants and moisture. Manual drain allows easy draining with slight push on drain.

Regulator is adjustable from 0 to 125 lbs. with quick response and accurate pressure regulation. Self-relieving, to allow pressure adjustment without air flow.

| | |
|------|-----------|
| 1/4" | 0906-0163 |
| 3/8" | 0906-0096 |
| 1/2" | 0906-0162 |
| 3/4" | 0906-0174 |

Call for other sizes.

Dri Air Automatic Separator

Separates condensed water and oil from compressed air. Collects rust, scale and sediment from air lines. Ejects liquids and matter automatically from air lines. Delivers clean, dry air to pneumatic tools and equipment.



| Pipe Size | Capacity | Item # |
|-----------|----------|-----------|
| 3/4" | 50 CFM | 0904-0001 |
| 1" | 100 CFM | 0904-0002 |
| 2" | 300 CFM | 0904-0003 |

Tanner Air-Line De-Icer

Stop air-line and equipment freeze-ups with the Tanner De-Icer system. These units add an effective anti-freeze vapor to every cubic inch of air that's used. No matter what the conditions, air-lines stay open. Formulated to operate in temperatures down to -70°F. Compact units are automatic, economical, and simple. Available for air-lines up to 2".



| | |
|-----------|----------|
| 0901-0009 | Quart |
| 0901-0010 | 1/2 Gal. |

"Freeze Ban" - TANNERGAS®

TANNERGAS® comes in liquid form, and is introduced into air lines by atomization. TANNERGAS bonds to moisture in the air line preventing freeze-up and therefore, preventing costly downtime. TANNERGAS is effective in both above-ground and open-air applications. TANNERGAS include a corrosion preventer, a rust inhibitor, a special lubricant that helps prevent O-rings and other rubber or synthetic parts from drying, and a unique bonding agent that adheres to moisture in the air line.

0901-0088 Quart





CatOil

CatOil is the superior industrial non-synthetic lubricant for your compressors, tools and robotics. CatOil protects O-Rings, Seals and Gaskets while withstanding pressures in excess of 100,000 psi.

| | |
|-------|------------|
| 4 oz | 99-03-0067 |
| Quart | 99-03-0068 |

Flexible Steel Hoses

| 12" | Item # |
|--------|-----------|
| 1/2" | 2703-0005 |
| 3/4" | 2703-0004 |
| 1" | 2703-0007 |
| 1-1/4" | 2703-0008 |
| 1-1/2" | 2703-0019 |

| 18" | Item # |
|--------|-----------|
| 1-1/2" | 2703-0014 |

Steel flexible hose provides help in correcting pipe misalignment problems and aides as a vibration isolator.



Fitted Hose Sections

Air hose assembled in 25' lengths, complete with stopcock in line and nipple in each end. Other lengths to order.
No. 1 Assembly- 3/8" inside diameter for Dallett hammers and similar tools. (2702-0010)
No. 2 Assembly- 1/2" inside diameter for plug drills, light rotating drills & air grinders. (2702-0009)



| | |
|------|-----------|
| 3/8" | 2702-0010 |
| 1/2" | 2702-0009 |

Hose Section

3/4" ID x 50' Length with couplings installed.
 3/4" ID x 50' Length

| Type | Item # |
|-------|-----------|
| Round | 2702-0012 |



Premium Flexible Air Hose

This hose is molded, braided construction in any length. The oil resisting neoprene tube is protected by two braids and a durable, smooth cover. Light weight and flexible. Hose sizes- 3/8", 1/2", 3/4", 1" and 1-1/4" inside diameters. Available in any length.



| | | | |
|-----------------|-----------|-----------------|-----------|
| 1/2" ID 250 psi | 2702-0023 | 3/4" ID 300 psi | 2702-0036 |
| 3/4" ID 250 psi | 2702-0024 | | |

25' Air Hose Assemblies

1/4" , 300psi
25ft Section
 3/8" , 300psi
25ft Section

| Size | Item # |
|------|-----------|
| 1/4" | 2702-0029 |
| 3/8" | 2701-0058 |



Other Sizes Available.

Suction Hose

This flexible suction hose is used on abrasive pickups or dust control equipment. It has a thick, smooth bore for long wear and unobstructed flow. Hose sizes: 2", 3", 4", & 5" inside diameters.



| | |
|----------------|-----------|
| 2" ID x 15' | 2706-0003 |
| 2" ID (Per ft) | 2706-0004 |

Premium Sandblast Hose

The extra thick inner tube is compounded of special resilient rubber to resist the impact of abrasive and stop static electricity buildup. Hose sizes- 1/2"-2" inside diameters. Available up to 50 ft. lengths.



| | | | |
|-----------------|-----------|---------------------|-----------|
| 3/8" ID x 1" OD | 2705-0008 | 3/4" ID x 1 1/2" OD | 2705-0007 |
| 1/2" ID x 1" OD | 2705-0001 | 1" ID x 1 1/4" OD | 2705-0006 |

Exhaust Hose

This sub-zero flexible exhaust hose is used on abrasive pickups or dust control equipment. It has a polyurethane lining providing resistance to abrasion and unobstructed flow.



| | | | |
|-------------|-----------|----------------|-----------|
| 2" ID x 15' | 2704-0006 | 3" ID x 15' | 2704-0004 |
| 3" ID x 10' | 2704-0003 | 4" ID (Per ft) | 2704-0002 |

Sandblast Couplers

150 PSI maximum recommended operating pressure. Manufactured to accepted industry standards and interchangeable with all major brands.

| | | |
|--------|---------|-----------|
| Brass | 3/4" ID | 2707-0093 |
| Brass | 1" ID | 2707-0075 |
| Alum | 1/2" ID | 2707-0083 |
| Alum | 1" ID | 2707-0121 |
| Gasket | | 2707-0020 |





Competitor 1125 Series Hose Reels



- Heavy gauge steel discs with rolled edges to add strength and prevent hose damage
- Solid steel frame and drum assembly
- Rewind hand crank is solid steel with a roller hand grip
- Swivel joint allows reel to rotate smoothly while connected
- Self aligning pillow block bearings support the drum assembly
- Positive gear drive rewind on all power rewind reels
- Hose I.D.: 3/8" - 1" Pressure: To 3,000 PSI
- Locking pin and tension brake standard on the hand crank model



Hand Crank Model:

Air Rewind Model:

Electric Model:

2709-0020

2709-0032

2709-0021

COXREELS® P Series Hose Reels

| Model | I.D. | Hose Length | Item# |
|----------|------|-------------|-----------|
| P-LP-350 | 3/8" | 50ft | 2709-0037 |
| P-LP-330 | 3/8" | 30ft | 2709-0036 |



Hose Included

SPRING DRIVEN FEATURES:

- Auto Rewind Easily Wraps, Stores & Protects Hose
- Heavy Gauge 1/4" Steel Base & Support Post
- Factory-Matched Cartridge-Style Spring Motor
- Brass NPT Swivel Inlet Machined From Solid (Zinc Plated Steel On HP Models)
- 1" Solid Steel Axle With 1" Lubricated Precision Bearings
- Guide Arm Adjusts To Wall, Floor & Overhead Positions
- Multi-Position Lock Ratchet Secures Hose At Desired Length
- Non-Corrosive Stainless Steel Spring, Pawl & Zinc Plated Ratchet



In-Line Check Valves

These cast brass check valves have been specifically designed for installation

into air compressor discharge lines. Extra heavy walled cast brass bodies, glass filled fluoro-polymers poppets, and stainless steel springs resist corrosion and insure long life. A plugged 1/8" NPT unloader port is standard. 250 psi maximum pressure, 450°F maximum temperature

Female

| | |
|--------|-----------|
| 1/4" | 0906-0039 |
| 3/8" | 0906-0046 |
| 1/2" | 0906-0050 |
| 3/4" | 0906-0063 |
| 1" | 0906-0078 |
| 1-1/4" | 0906-0083 |
| 1-1/2" | 0906-0089 |

Pop Safety Valve



This Bronze Safety Valve with stainless steel seats and discs, has flat seats and wing-guided discs. High discharge coefficient. ASME standard- NB certified. Specify set pressure and inlet size. Available in 1/4" to 1" NPT.

Specify pipe thread and set pressure when ordering.

0906-



In-Tank Check Valves

One piece brass bodies, stainless steel springs, and glass filled fluoro-polymers poppets all add up to long term reliability, while the eight discharge holes insure quiet operation. Valves may be disassembled for cleaning or repair. Valves are 100% tested for backflow leakage performance. 450 psi max pressure, 400°F max temperature.

Female

| | |
|-----------------|-----------|
| 3/8" x 3/8" | 0906-0019 |
| 3/8" x 1/2" | 0906-0026 |
| 1/2" x 1/2" | 0906-0027 |
| 1/2" x 3/4" | 0906-0040 |
| 3/4" x 3/4" | 0906-0041 |
| 3/4" x 1" | 0906-0049 |
| 1" x 1" | 0906-0127 |
| 1-1/4" x 1-1/4" | 0906-0328 |

Male

| | |
|-------------|-----------|
| 3/8" x 3/8" | 0906-0172 |
| 3/8" x 1/2" | 0906-0118 |
| 1/2" x 3/8" | 0906-0172 |
| 1/2" x 1/2" | 0906-0120 |
| 3/4" x 3/4" | 0906-0122 |
| 3/4" x 1" | 0906-0121 |

Unloader Pilot Valve



| Size | Item # |
|-------------|-----------|
| 110-125 psi | 0906-0152 |
| 100-125 psi | 0906-0114 |
| 90-125 psi | 0906-0156 |
| 80-125 psi | 0906-0155 |

The Unloader Pilot Valve monitors receiver tank pressure to unloading device, instructing air compressor to load and/or unload. The drop-in pressure may be adjusted for operation from 3% to 30% of maximum receiver pressure. Conrader is the dependable valve for compressor operation.

GCT Stopcock



| Fem x Fem | | Male x Male | |
|-----------|-----------|-------------|-----------|
| Size | Item # | Size | Item # |
| 1/4" | 2707-0127 | 3/8" | 2707-0074 |
| 3/8" | 2707-0056 | 1/2" | 2707-0073 |

Stop expensive air loss with this bronze shut-off valve. Fits easily in hose line with its barbed nipple ends. Ideal way to control air flow at point of use.

Lever Handle Valve

This high pressure ball valve is an inexpensive shut off for use with air or liquid. Does the work of more expensive valves.

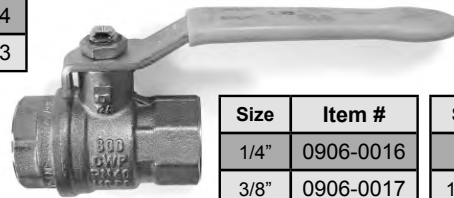

| Size | Item # | Size | Item # |
|------|-----------|--------|-----------|
| 1/4" | 0906-0016 | 1" | 0906-0042 |
| 3/8" | 0906-0017 | 1-1/4" | 0906-0183 |
| 1/2" | 0906-0018 | 1-1/2" | 0906-0164 |
| 3/4" | 0906-0037 | | |

Kwik-Change Couplings & Nipples

Change air hammers on hose with a snap of the fingers. Swivel action eliminates hose kinking. Every coupler has a check valve which automatically shuts off air the instant the unit is disconnected. Eliminates wear on threads. Sizes- 1/4", 3/8" & 1/2".



| Type | Coupling | Item # | Type | Nipples | Item # |
|-------|--------------------|-----------|-------|-------------------------|-----------|
| Brass | 1/4" Fem 1/4" Fem | 2707-0029 | Brass | 1/2", 1/2" Male | 2707-0025 |
| Brass | 1/4" Fem 1/4" Male | 2707-0052 | Brass | 1/2", 3/8" Male | 2707-0026 |
| Brass | 1/4" Fem 3/8" Fem | 2707-0055 | Steel | 1/4", 3/8" Fem | 2707-0021 |
| Brass | 1/4" Fem 3/8" Male | 2707-0057 | Steel | 1/4", 1/4" Fem M-Style | 2707-0019 |
| Brass | 1/2" Fem 1/2" Fem | 2707-0082 | Steel | 1/4", 1/4" Male M-Style | 2707-0018 |
| Brass | 1/2" Fem 1/2" Male | 2707-0084 | | | |

Grooved Hose Nipples



| Type | Size | Item # |
|-------|-------------|-----------|
| Steel | 1/4" x 1/8" | 2707-0135 |
| Steel | 3/8" x 1/4" | 2707-0028 |
| Steel | 3/8" x 3/8" | 2707-0027 |
| Steel | 3/8" x 1/2" | 2707-0032 |
| Steel | 1/2" x 1/4" | 2707-0031 |
| Steel | 1/2" x 3/8" | 2707-0033 |
| Steel | 1/2" x 1/2" | 2707-0034 |
| Steel | 1/2" x 3/4" | 2707-0035 |
| Steel | 3/4" x 1/2" | 2707-0061 |
| Steel | 3/4" x 3/4" | 2707-0058 |

Hose sizes- 3/8", 1/2" and 4".

| Type | Size | Item # |
|-------|-------------|-----------|
| Brass | 1/4" x 1/4" | 2707-0088 |
| Brass | 3/8" x 1/4" | 2707-0089 |
| Brass | 3/8" x 3/8" | 2707-0023 |
| Brass | 1/2" x 1/4" | 2707-0126 |
| Brass | 1/2" x 3/8" | 2707-0024 |

Universal Couplings



| (1) Female | | (3) Hose Coupling | |
|------------|-----------|-------------------|-----------|
| 3/8" | 2707-0042 | 3/8" | 2707-0046 |
| 1/2" | 2707-0043 | 1/2" | 2707-0047 |
| 3/4" | 2707-0044 | 3/4" | 2707-0048 |
| 1" | 2707-0045 | 1" | 2707-0049 |

| (2) Male | | (4) Triple Conn. | |
|----------|-----------|------------------|--|
| 3/8" | 2707-0038 | 2707-0070 | |
| 1/2" | 2707-0039 | | |
| 3/4" | 2707-0040 | | |
| 1" | 2707-0041 | | |

Gaskets

2707-0020

Grooved Hose Mender



Positive method for joining air hoses. Use up your short lengths of hose.

| Type | Size | Item # | Steel | 3/4" | 2707-0037 |
|-------|------|-----------|-------|------|-----------|
| Steel | 3/8" | 2707-0051 | Brass | 3/4" | 2701-0048 |
| Steel | 1/2" | 2707-0036 | Brass | 1" | 2707-0049 |

Worm Drive Clamps



Reusable security pressure grip. For hoses from 3/8" to 1-1/2" inside diameter.

2701-



2701-0012

Blo Gun

OSHA type Blow Gun controls air stream pressure at the nozzle tip, yet provides enough volume for safe air nozzle cleaning.

Carry Clamps

The DP Carry Clamps allow you to safely lift and carry your stone without hurting your back. Clamp design uses the weight of the stone to provide clamping action. That means the heavier the load, the more clamping action. Sold in pairs. **Max opening: 1 3/4"**



2507-0020

Replacement Rubber 99-453-0001

FREE CASE

Stone Carrying Clamp

Better Safe Than Sorry

- **Large grip range: 0- 6cm**
- Net weight: 6.6lbs
- Dimensions: 11 1/4" x 4 3/4" x 9 7/16"
- Lifting capacity per set: 440lbs
- Long handles = more leverage



2507-0082



Lite Stone Panel Carriers with Cable

2507-0078

- Easy to use
- Locks on panel automatically
- Lifting cap. per set : 330lbs
- Rubber lined spring loaded heads
- Aluminum body & molded rubber hand grips
- Grip range 0" to 2 1/2"

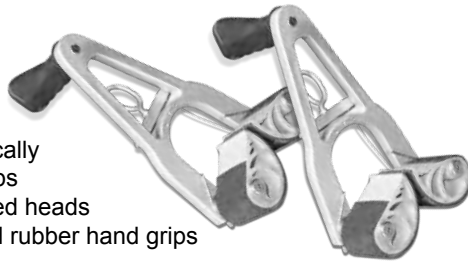

Ratchet Seam Setter

2523-0010

Positions countertop horizontally & vertically. Dual-action ratcheting handle allows horizontal adjustments to tighten or loosen joint.

Includes wooden case.



4" Hand Suction Cups

66 lb. Flat Loading Cap. ↑



2510-0020

4" Double Hand Suction Cup

110 lb. Flat Loading Cap. ↑



55 lb. Side Loading Cap. ↑

2510-0027

4" HD Double Hand Suction Cup

132 lb. Flat Loading Cap. ↑



55 lb. Side Loading Cap. ↑

2510-0041



WOODS Hand Vacuum Cups

8" N4000

Tough light Lexan pump handle valve. 125 lb. loading capacity.

8" 2510-0002



9" N5450

Tough metal pump handle valve. 150 lb. loading capacity.

9" 2510-0004

Audio Alarm Plunger

2510-0050



Excellent for placing stone tiles and slab carrying using more Hand Cups to handle the weight. Both come with plastic carrying case.

Vacuum Suction Cup

Plastic Handle 176 lb. Loading Capacity ↑

8" 2510-0032

Metal Handle 264 lb. Loading Capacity ↑

9" 2510-0033



Excellent for placing stone tiles and slab carrying using more Hand Cups to handle the weight. Both come with plastic carrying case.

Enclosed track free standing workstation bridge crane systems by SPANCO are supplied in standard sizes ranging from 250 lb. to 4,000 lb. capacity. These overhead bridge cranes go up to 34', with bridge crane spans and runway lengths to 124'. Runways are infinitely extendable beyond standard 124' length. Custom design for free standing workstation bridge cranes is available to meet specialized requirement.

FREESTANDING BRIDGE CRANES



Features:

- Available in steel, aluminum, and stainless steel.
- Very easy to install, relocate, and expand.
- Provide ease of movement and positioning.
- Doesn't put stress on the building's overhead structure.

Call for Sizing & Pricing

This steel constructed E Series gantry crane is available in a fixed height up to a 12-foot span and 10-foot height to 5-ton capacity with 10' available under the beam. Also available is adjustable height for 11'6" span up to 3 ton capacity. Maximum heights on the adjustable gantry crane models range from 7' to 14'. The E Series gantry crane is constructed with high strength mechanical tubing and equipped standard swivel casters with mold-on polyurethane wheels for ease of movement.

E SERIES GANTRY CRANES



Wheel brakes, swivel locks, and other wheel and caster styles are available for the E Series gantry crane.

Call for Sizing & Pricing

The free standing jib crane is available with 360-degree jib rotation. Free standing jib cranes require no additional support aside from an adequately sized permanent foundation.

FREESTANDING JIB CRANES



For this jib crane, standard spans and under boom heights are available up to 20'. The top bearing assembly on a free standing jib crane utilizes a Timken tapered roller bearing provided with a grease fitting for proper lubrication.

Standard optional features for a free standing jib crane include: air swivels, collector rings, air and electric motorized rotation, taglines, festoons and special controls for all environments. Specialty paint finishes or hot dip galvanizing is also available. Capacities for this jib crane range up to 15 tons, spans to 60', and heights to 40' available through special order, depending on capacity.

Call for Sizing & Pricing

Tiger T-2060



- 360° rotation
- Remote control pendant for electric winch (10').
- 25' of 3/16" winch cable
- 3 boom positions: 3', 4', and 5'

The T-2060 Electric Folding Crane is designed to lift up to 2,000 lbs. and use a minimum of space for mounting and storage. This versatile unit can be installed on a chassis as light as 3/4 ton (reinforced) and used for general material handling.

Tiger T-3215E



- 360° continuous rotation
- 9'-15' Hydraulic Boom Extension
- Detachable remote control pendant (25')
- 14" x 14" Mounting Space Required
- 12 VDC

The T-3215E is an Electric/Hydraulic Crane which can lift up to 3,200 lbs. No costly pump or PTO is required, as the unit can be powered by the vehicle, or auxiliary battery. Lift and Extension Cylinders are Equipped with Counterbalance Safety Valves

Tiger T-5031E



- 5,000 lb Lifting Capacity
- 1,395 lbs. Operating Weight
- 20" x 30" Mounting Space Required
- 12 VDC
- Detachable remote pendant

The T-5031E is an Electric/Hydraulic crane with 21.5' of hydraulic reach and hex boom construction for superior rigidity. Features 25' tethered remote control, and 400 degree rotation.

Tiger T-6541E

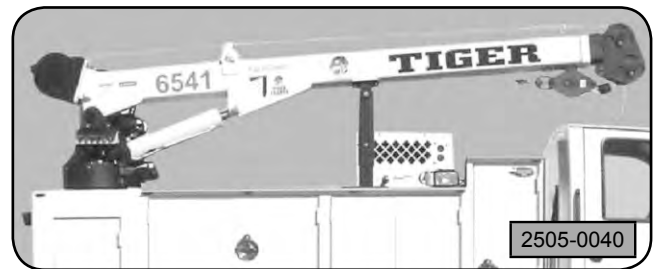

- 6,500 lb Lifting Capacity
- 1,565 lbs. Operating Weight
- 20" x 30" Mounting Space Required
- 12 VDC

The T-6541E is an Electric hydraulic crane, 21.5' of reach with 1 hyd extension, 36fpm of no load single speed, 25' corded remote, 400 degree rotation, Anti-two block and overload protection.

Ruger Hoists

2504-

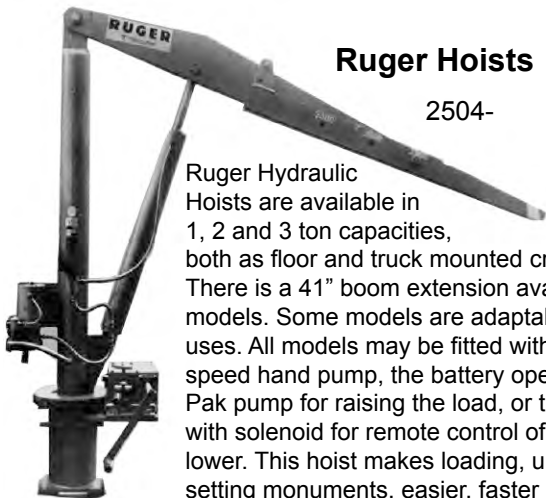

Ruger Hydraulic Hoists are available in 1, 2 and 3 ton capacities, both as floor and truck mounted cranes. There is a 41" boom extension available for all models. Some models are adaptable to both uses. All models may be fitted with the two speed hand pump, the battery operated Power Pak pump for raising the load, or the Power Pak with solenoid for remote control of raise and lower. This hoist makes loading, unloading and setting monuments, easier, faster and safer.



Many sizes and options available call today.

Sto-Away® Bumper Cranes

Fold Away Power Bumper Cranes Standard Features:

- Removable Hand Pendant
- Emergency Kill Switch
- Sill use truck bed and tailgate
- 3 year warranty
- 270° Rotation (truck protection zone)
- Aircraft quality pulley pins & locking keepers

| Model | Capacity | Reach |
|---------|----------|-------|
| SR-5T | 2,000 | 48" |
| CSR-520 | 2,000 | 54" |

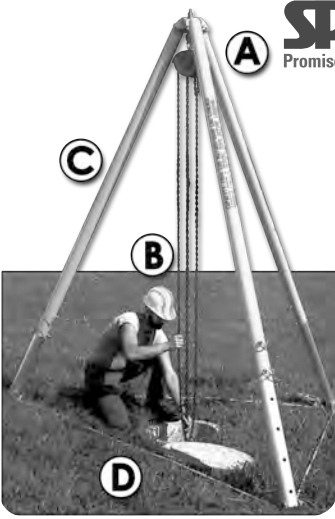

Tripods

Sturdy, lightweight tripods set up quickly for heavy lifting in areas with no overhead support. Independently adjustable legs permit use on uneven ground and

adjust on 6" centers. Standard lashing kit prevents the legs from spreading on hard or soft surfaces and is included with every tripod. Steel or aluminum construction. Capacities from 1-3 tons

| Capacity | Height Eye Bolt To Floor | | Overall Length | | Dimension Between Legs Height | | Net LBS | FF = Flat Feet MF = Mud Feet | | |
|-------------|--------------------------|--------|----------------|--------|-------------------------------|--------|---------|---------------------------------|-----------|----|
| | MAX | MIN | MAX | MIN | MAX | MIN | | Model | Item# | |
| 1 TON Steel | 13'-9" | 8'-7" | 16'-2" | 10'-2" | 14'-6" | 9'-3" | 178 | ATS-02-1309 | 2512-0014 | - |
| 1 TON Alum. | 8'-7" | 5'-2" | 10'-0" | 6'-0" | 9'-2" | 5'-10" | 49 | ATA-02-0805 | 2512-0008 | MF |
| | 11'-2" | 6'-10" | 13'-0" | 8'-0" | 11'-9" | 7'-7" | 61 | ATA-02-1107 | 2512-0007 | FF |
| | 13'-9" | 8'-7" | 16'-2" | 10'-2" | 14'-6" | 9'-3" | 140 | ATA-02-1309 | 2512-0010 | FF |
| 2 TON Steel | 13'-9" | 8'-7" | 16'-2" | 10'-2" | 14'-6" | 9'-3" | 202 | ATS-04-1309 | 2512-0013 | FF |
| 2 TON Alum. | 11'-2" | 6'-10" | 13'-0" | 8'-0" | 11'-9" | 7'-7" | 119 | ATA-04-1107 | 2512-0001 | MF |
| | 13'-9" | 8'-7" | 16'-2" | 10'-2" | 14'-6" | 9'-3" | 148 | ATA-04-1309 | 2512-0002 | FF |
| | 13'-9" | 8'-7" | 16'-2" | 10'-2" | 14'-6" | 9'-3" | 148 | ATA-04-1309 | 2512-0003 | MF |
| | | | | | | | | | 2512-0015 | FF |

Capabilities to count on:

- Capacities in push operation: 1 and 2 Ton capacity and up to 24', in both top and underhung designs.
- Fabricated from structural steel for optimal strength and rigidity.
- Large diameter wheels machined from ductile iron and equipped with deep grade ball bearings allow the crane to roll easily.
- Rubber bumpers, drop stops, and rail sweeps are standard.

Supplied components:

- Bridge beam assembly with bracing.
- Documentation, including assembly instructions, crane operator's guide, and owners manuals.
- Trolley hoist available in a wide selection of low headroom styles.

- End trucks
- Touch up paint.
- One year warranty.



Crane Kits



**Series 300
Top Running Push
Complete Crane**

**Series 300
Underhung Push
Complete Crane**



CF Hand Chain Hoists

Features:

- Easy usage and low maintenance.
- Die-cast aluminum body with high tensile, heat-treated main shaft, pinions, and load gears to stand up to your toughest demands.
- 10 foot standard lift.

2 Year Limited Warranty

| Cap. (Tons) | Head-room (inches) | Pull to Lift Load (lbs.) | Overhaul Ratio | Load Chain Diameter (mm) x Chain Fall Lines | Net Weight (lbs) | Item# |
|-------------|--------------------|--------------------------|----------------|---|------------------|-----------|
| .5 | 12.8 | 60 | 19 | 5.0 x 1 | 26 | 2506-0019 |
| 1 | 14.6 | 72 | 31 | 6.3 x 1 | 31 | 2506-0020 |
| 1.5 | 17.3 | 84 | 41 | 7.1 x 1 | 42 | 2506-0022 |
| 2 | 20.1 | 80 | 63 | 6.3 x 2 | 49 | 2506-0024 |
| 3 | 23.2 | 92 | 81 | 7.1 x 2 | 66 | 2506-0026 |
| 5 | 24.4 | 92 | 134 | 7.1 x 3 | 86 | 2506-0040 |

Harrington's Model CF Series Hand Chain Hoist is a practical choice for efficient, trouble-free service. Special heat treated load chain and pre-lubricated sealed ball bearings contribute to long service with low maintenance. All hoists are load tested and meet ANSI B30.16 and OSHA standards.



NER Electric Chain Hoist

This dependable electric chain hoist features a die-cast aluminum body. Totally enclosed weather resistant construction. All hoists are equipped with motor brake, mechanical load brake, chain container and push button control. Available in seventeen models from 1/4-20 ton cap. 230/460 volt 3 phase and 10' lift as standard. Other Voltages and suspensions available.



1 Year Limited Warranty

| Lifting Cap | Lift Speed | Item # |
|-------------|------------|-----------|
| 1/2 Ton | 15 FPM | 2506-0010 |
| 1 Ton | 14 FPM | 2506-0011 |
| 1 Ton | 28 FPM | 2506-0012 |
| 1-1/2 Ton | 18 FPM | 2506-0013 |
| 2 Ton | 14 FPM | 2506-0014 |
| 2 Ton | 28 FPM | 2506-0015 |
| 3 Ton | 16 FPM | 2506-0016 |
| 5 Ton | 11 FPM | 2506-0090 |



Trolleys

Capacities 1/4 to 5 tons. An economically priced trolley for intermittent use. Geared models from 1/4 to 5 tons. Motorized models from 1/4 to 3 tons. Other styles available.





Quick release system makes switching plates a snap.

Welded handles for complete placement control.

Stay-open locking system.

360° swivel coupler.

Sure-grip pads hold materials more securely.



**EZ-Set
SCISSOR
FRAMES**
3,000 lb. Cap.
2507-0057

EZ-Set LIFTING PLATES

| | |
|---------------------|-----------|
| Boulder 24" | 2507-0044 |
| Adjustable Straight | 2507-0051 |
| Slant-Style | 2507-0052 |
| Straight 18"-24" | 2507-0047 |
| Straight 24"-30" | 2507-0046 |



Setting Trucks

Built tough to handle the large dies. Stands 57-1/2" high and has 21-5/8" wide frame with 5-1/4" x 24" rubber covered toe plate. Non-marking rubber strips are installed on the exposed frame rails for load protection. Equipped with four 12-1/2" x 3.50 pneumatic wheels. Weighs 95 lbs & has 2,000 lb load capacity. Features dual wheels for maximum maneuverability with heavy loads.

With Brake
2505-0156

Frame Rubber
2505-0021
Toe Plate Rubber
2505-0002

No Brake
2505-0157

S-5A Setting Truck

Built tough to handle the large dies. Stands 60" high and has a 23" wide frame with 5" x 24" rubber covered toe plate. Non-marking rubber strips are installed on the exposed frame rails for load protection. Equipped with four 12" x 3.50 pneumatic wheels. Weighs 120 lbs and has a 2,000 lb load capacity. Features dual wheels for maximum maneuverability with heavy loads.



With Brake
2505-0004



Peerless Lever Hoist

Capacities 3/4 to 9 tons. Ratchet power design with link chain. This system provides easy operation and freedom from maintenance. Body and handle made of high strength aluminum alloy for lightweight and corrosion resistance. Standard lift is 15 ft., other lengths available



2 Year Limited Warranty

| Type | Item # |
|--------------|-----------|
| 1 TN 10' | 2506-0027 |
| 1 TN 15' | 2506-0028 |
| 1-1/2 TN 10' | 2506-0029 |
| 1-1/2 TN 15' | 2506-0030 |
| 2 TN 10' | 2506-0031 |
| 2 TN 15' | 2506-0032 |
| 3 TN 10' | 2506-0033 |
| 3 TN 15' | 2506-0034 |

Wagon Trucks, Steer Wagons

Tongue - safety type with "t" handle for manual operation (will not drop to floor) wheels equipped with roller bearings and grease zerks

Frame - formed steel channel

Fifth wheel - grease plate type

Deck - kiln dried hardwood (flush) or steel

Maximum speed - 5 m.p.h.

Load capacities -

1,500-5,500 lbs.

OPTIONS

1. Ball bearing 5th wheel plates
2. Couplers for tractor towing

Call for more info.



2508-

Heavy Duty Platform Trucks



2508-

- Angle iron frame
- Steel and Wood deck
- Two pipe pockets each end
- Bolted-on casters

Platform trucks are available in custom sizes with wooden or steel decks.

Load capacities range from 1,400-4,600 lbs.

Push handles also available.

Call for more info.

Heavy Duty Lift Jack Skids

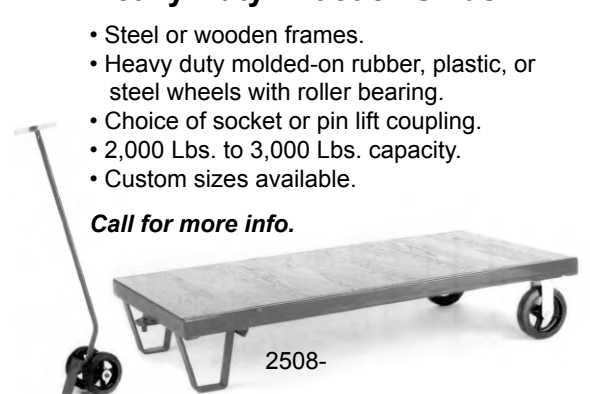

2508-

- Steel or wooden frames.
- Heavy duty molded-on rubber, plastic, or steel wheels with roller bearing.
- Choice of socket or pin lift coupling.
- 2,000 Lbs. to 3,000 Lbs. capacity.
- Custom sizes available.

Call for more info.



Monumentall Lifting Device

- 6 Position adjustments for 3" to 15" grip.
- **2,500 lb capacity.**
- Single line device - Works with any hoist lifting machine.
- Polyurethane gripping pads, neoprene pads on metal edges; Protects from dings, won't mark finished surfaces.
- Semi automatic operation w/manual over center release handle.
- OSHA accepted, confirms to ANSI B30,5B - 1991.
- All weather device.

2507-0016

Type-C Lifting Clamp

| | | |
|--------|-----------|-----------|
| 3/4 TN | 3" OP | 2502-0001 |
| 1 TN | 5-1/2" OP | 2502-0002 |
| 2 TN | 8-3/4 OP | 2502-0006 |



Ideal for lifting thin panels and veneers. "C" clamps are furnished with a 1/2" stud and composition pad at point "A". Pad surface should be periodically roughed-up with a coarse grit sand paper for better gripping action.



Swivel Hook

- 99-003-0173 1.5 Ton Capacity
- 99-003-0174 3 Ton Capacity



Anchor Shackles

- 1 3/4" Gap
- 99-003-0036 3 Ton Capacity



AARDWOLF® Scissor Lifter 350

2507-0083

Clamp weight: 105 lbs
Grip range: 10" - 14"
 Work load: 2,200 lbs
 Dimensions: 21 11/16" x 22" x 8"
 Auto locks & unlocks
 Vulcanized rubber pads



AARDWOLF® Scissor Lifter 300

2507-0093

Clamp weight: 110 lbs
Grip range: 6" - 12"
 Work load: 3,300 lbs
 Dimensions: 22" x 8" x 26"
 Auto locks & unlocks
 Vulcanized rubber pads



Curb Lifting Squeeze Clamp

2507-0017

Clamp weight: 61 lbs
Max Opening: 6"
 Work load: 1,500 lbs
 Auto locks & unlocks
 Rubber holding pads

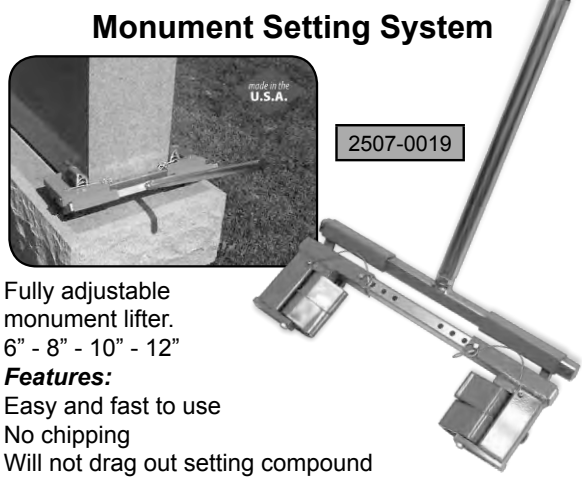

Monument Setting System

2507-0019

Fully adjustable monument lifter. 6" - 8" - 10" - 12"
Features:
 Easy and fast to use
 No chipping
 Will not drag out setting compound
 Can be used to easily pick up resets
 Comes apart for easy storage
 Lighter than other setting devices
 Self adjusting - no bolts or nuts to tighten
 No experience required for the perfect set



AARDWOLF® Monument Setting System

2519-0038

Grip range: 0 - 12"
 Load capacity: 2,200 lbs
 Weight: 82 lbs.

Package Dimensions:
 L22.04" x W7.28" x H12.20"



Non-Slip Setting Clamp

2507-0009

The set consists of two corner brackets, bolt, nuts, and wrench to form a single clamp as shown. Standard bolt set takes dies 8" to 14" in thickness. And extra long bolt for dies 14" to 20" is available. Clamp is used for safe setting of all polished and finished work. It pays to be sure when setting.

AARDWOLF® Forklift Booms



- Boom extension is designed so it cannot be pulled all the way out.
- The boom is firmly secure onto fork blades by two bolts located at the back of each fork pocket and restraint pins.
- Slip onto forks design with fork pockets 6" W x 2" H
- Fork pockets are 15" to centers.

| | | |
|-----|-----------|-----------|
| FB1 | 4,409 lbs | 2519-0030 |
|-----|-----------|-----------|

- Weight - 198 lbs
- **Maximum load capacity,**
Fully retracted - 3,306 lbs., fully extended - 1,102 lbs.
- Manually telescopes, 4.75' - 8.5" in 3 increments of 20"

| | | |
|-----|-----------|-----------|
| FB2 | 6,614 lbs | 2519-0027 |
|-----|-----------|-----------|

- Weight - 286 lbs
- **Maximum load capacity,**
Fully retracted - 5,291 lbs., fully extended - 1,322 lbs.
- Manually telescopes, 6.5' - 11' in 2 increments of 21"



2519-0037

Forklift Boom



Fabricated from standard steel. Telescoping extends up to 12 feet (144"). 4,000 lb. capacity—meets AWS standards. Fork pockets 7-1/4" x 2-3/4" H on 24" centers. 36" safety restraint attaches to forklift truck. 2-ton hook with swivel shackle.

Low Headroom Multiple Spread Lifting Beam



2519-0042

- 3 Spread points
- Swivel hooks with hook latches standard.
- Complies with ASME standards.
- Capacity: 5 Tons
- Head Room: 21 1/2"
- Spread: 8ft (outside)
- Weight: 280 lbs

Monument Jacks



Made from high quality Steel, these basic jacks will beat any pry bar you own now. Designed to move Headstones and flat markers.

| | |
|--|-----------|
| Basic - 72" L, 17 lbs. Rated 1,500 lbs. | 5106-0040 |
| Little Giant - 72" L, 15 lbs. Rated 3,000 lbs. | 5106-0041 |

Web Sling Triangles

| Size | Working Load Limit | Item # |
|------|--------------------|-----------|
| 3' | 13,050 lbs. | 5303-0017 |
| 4' | 10,800 lbs. | 5303-0018 |



- Finish: hot dip galvanized.
- Shackle body: carbon steel, heat treated.
- Shackle pin: alloy steel, heat treated.

Nylon Heavy Duty Ratchet Strap

10,000 lb. rated nylon web cargo tie down straps are 2" wide, includes heavy duty closed handle ratchet. Available with a flat or U-hook.



| Hook | Size/Type | Item # |
|------|------------------|-----------|
| Flat | 27" - 2" Ratchet | 5302-0006 |
| U | 27" - 2" Ratchet | 5302-0005 |

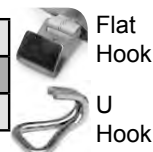

Forklift Double-Fork Hook Plate

- Safety chain and clasp secures the hook plate to the fork truck to prevent sliding
- Heavy-duty steel frame construction
- Forged steel hooks with galvanized steel safety latch
- Slanted fork openings prevent the hook plate from being used upside down
- Includes swivel hook with anchor shackle

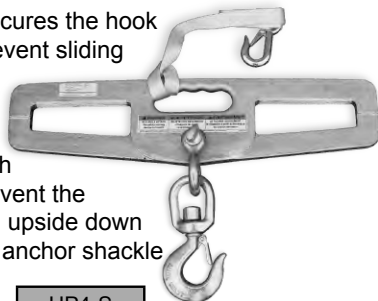

HP4-S

4,000 lb Cap.
Fork Open: 6-1/4w x 1-3/4h

Granite City Setting Bars

Setting bars are made to order in the size stock, length and style you specify. Only the highest grade of carbon tool steel is used in forging Granite City setting bars. Call for sizes and styles.



| Size | Item # |
|-------------------------|-----------|
| 3/4" x 30" | 5106-0030 |
| 3/4" x 36" | 5106-0028 |
| 7/8" x 30" | 5106-0031 |
| 7/8" x 30" with Rollers | 5106-0018 |

| | |
|------------|-----------|
| 7/8" x 36" | 5106-0032 |
| 7/8" x 42" | 5106-0002 |
| 7/8" x 48" | 5106-0029 |
| 1" x 60" | 5106-0001 |



Type-B Rollers and Shackles #1722

The type "B" Rollers and Shackles are designed for heavy-duty lifting. The maximum load is 4 tons. Use with endless stone slings up to 4-1/2" width.

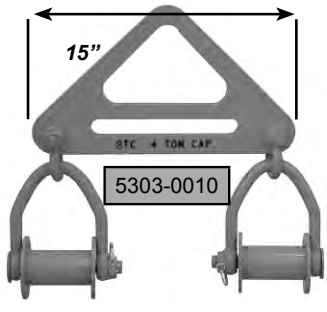

Straight Bar Type Shackle

The Straight Bar Shackle is built for use where headroom is low. Slings are suspended within 4" of the hoist hook for maximum use of headroom. Depending upon the size of the load, slings may be suspended from 11", 20" or 29" centers. Well constructed and balanced. Available in short bar type, 24" length with two place settings. Standard type, 34" length with three place settings. 4" rollers.

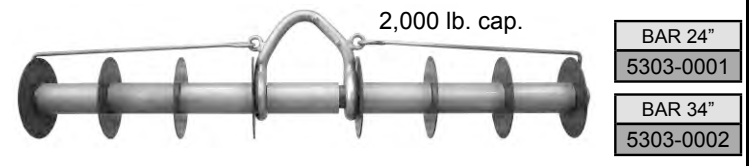

St. Cloud Type Rollers and Shackles

These rollers and shackles are used where headroom is a problem. Slings are suspended from aluminum rollers just 10" below the load hook to save space. Rollers are plain with a slight crown in the center and roll independently of the close fitting flanges. Rollers take slings up to 4" width. This assembly is handy in all plants and on truck cranes where lifting height is limited.

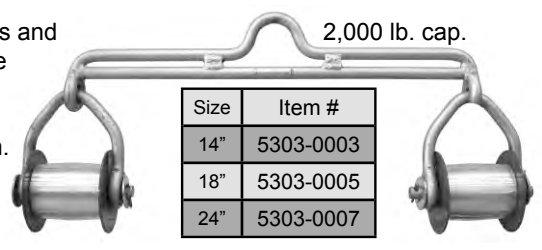

Type-A Rollers and Shackles

Most popular of all hardware for handling endless slings. The A-shaped yoke is designed to give equal and sufficient spread, allowing balanced suspension and freedom of movement of the load at all angles. Slings are suspended on crowned aluminum rollers, which roll independently of the close fitting flanges. This makes turning of the load in the sling easier. Rollers will handle up to 4" wide slings.

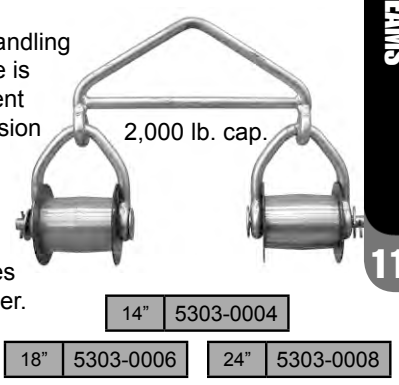

Spreader Lifting Beam

Adjustable lifting points
Handle both wide and unbalanced loads
Optional: Swivel hooks and shackles

Specifications

Working Load Limit (WLL): 2.5 Tons
Weight: 92.6 lbs

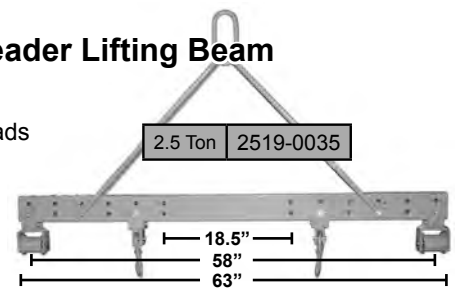

Specifically designed for the stone industry. The spreader bar, in combination with endless slings, is an invaluable piece of equipment where stone is required to be rolled over. Slings are suspended on crowned aluminium rollers. This makes turning of the load in the sling easier. Rollers will handle up to 100mm wide slings. Swivel hooks can be used in place of rollers. Overall width 2000mm.

Pin Lewis (sold in pairs)

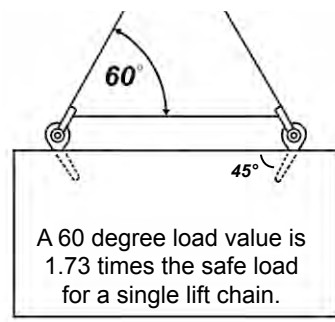

| Pin Dia. | Pin Length | Pin Cap. | Size Alloy Chain | Item # |
|----------|------------|-----------|------------------|-----------|
| 1/2" | 3-1/2" | 3/8 ton | 1/4" | 2518-0014 |
| 5/8" | 4" | 3/4 ton | 1/4" | 2518-0008 |
| 3/4" | 4-1/2" | 1-1/2 ton | 1/4" | 2518-0009 |
| 7/8" | 5" | 3 ton | 3/8" | 2518-0004 |
| 1" | 6" | 4-1/2 ton | 3/8" | 2518-0010 |
| 1-1/4" | 6-1/4" | 4-1/2 ton | 3/8" | 2518-0017 |
| 1-1/8" | 6-1/2" | 6 ton | 1/2" | 2518-0005 |
| 1-1/4" | 7" | 9 ton | 1/2" | 2518-0015 |
| 1-1/2" | 6-3/4" | 9 ton | 1/2" | 2518-0019 |
| 1-1/2" | 7" | 12 ton | 5/8" | 2518-0007 |
| 2" | 9" | 20 ton | 7/8" | 2518-0016 |



H.D. Straight Bar Type Shackle



35" Swing Bar w/Pipe Roller & Washers
From 1 - 4 Ton Capacity
Use up to 4in Slings

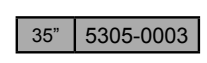

Double Line Nylon Slings - Pairs

Few fibers have the strength of nylon. This soft, flexible material is only 5/32" in thickness. Can be made into slings of any length. Nylon is resistant to grease, oil, mildew, rotting and aging. Specify width and length, hanging double, when ordering endless type, and width and length when ordering eye and eye choker style. Available in widths from 1" to 6".

Other sizes and plys available

10,000 lb.



| Size | 1 PLY |
|------------|-----------|
| 3" x 3' 6" | 5304-0049 |
| 3" x 4' | 5304-0053 |
| 3" x 4' 6" | 5304-0060 |
| 3" x 5' | 5304-0066 |
| 3" x 5' 6" | 5304-0071 |
| 3" x 6' | 5304-0078 |
| 3" x 7' | 5304-0084 |
| 3" x 8' | 5304-0093 |

Twintex Nylon Endless Stone Slings - Pairs

Rugged slings designed expressly for lifting stone, building panels, and many other rough surfaced materials. Made of woven nylon web reinforced with special surface gripping and abrasion resistant facing yarns. 8,000 lb. vertical lift cap. Available in 4" width only. Please specify length.

Other sizes and plys available

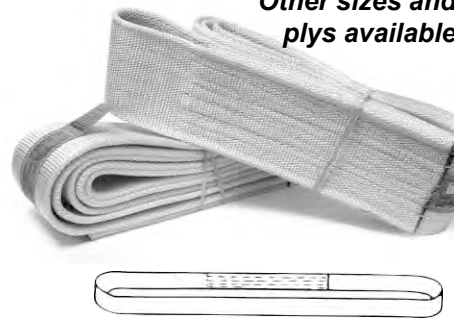

| Size | 1 PLY |
|------------|-----------|
| 4" x 3' 6" | 5304-0002 |
| 4" x 4' | 5304-0086 |
| 4" x 4' 6" | 5304-0091 |
| 4" x 5' | 5304-0099 |
| 4" x 5' 6" | 5304-0172 |
| 4" x 6' | 5304-0109 |
| 4" x 7' | 5304-0113 |
| 4" x 8' | 5304-0119 |

Crate Sling - Pairs



| Size | 1 PLY | 2 PLY |
|----------|-----------|-----------|
| 1" x 3' | 5304-0003 | 5301-0001 |
| 1" x 4' | 5304-0007 | 5301-0002 |
| 1" x 5' | 5304-0010 | 5304-0001 |
| 1" x 6' | 5304-0013 | - |
| 1" x 8' | 5304-0020 | 5301-0005 |
| 1" x 10' | 5304-0024 | - |
| 1" x 12' | 5304-0030 | - |

Light weight, easy to handle nylon sling designed to handle crated stone products. Available in single or 2-ply endless construction. 1" wide by any length specified.

Eye-to-Eye Half Twist Choker Slings - Each

Eye-to-Eye Half Twist Choker Slings the answer to all your web sling lifting and or pulling applications. Used to lift markers, slants, bases and dies in a hurry. Slip one end underneath stone and come up through the eye on other end, tighten. Then put open eye on hook of your hoist. Different widths and material strengths are available. (Use wear pads or sleeves on sharp edges).

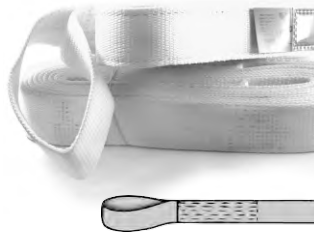

| Twist Eye | |
|-----------|-----------|
| Size | 2 PLY |
| 2" x 8' | 5304-0267 |
| 2" x 6' | 5304-0359 |
| 2" x 12' | 5304-0268 |

| Flat Eye | |
|----------|-----------|
| Size | 2 PLY |
| 2" x 8' | 5304-0139 |
| 2" x 10' | 5304-0069 |
| 2" x 12' | 5304-0140 |
| 2" x 14' | 5304-0048 |
| 2" x 16' | 5304-0095 |
| 2" x 18' | 5304-0102 |
| 2" x 20' | 5304-0050 |

Bundle Sling - 2 ply - Each

| Size | Item # |
|---------------------|-----------|
| 4" x 18' Eye to Eye | 5304-0450 |
| 6" x 3' Sleeve | 5304-0452 |

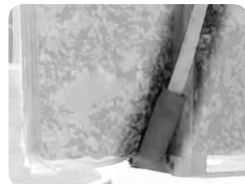

Endless in configuration, and are constructed from endless yarns of 100% polyester fiber encased in a tough polyester woven tube. Tulflex are superior in their ability to conform to the shape of the load and may be used in all three types of hitches. Specify desired capacity and length.

Tulflex Round Slings - Each



| Size | Item # |
|------|-----------|
| 3' | 5304-0129 |
| 6' | 5304-0065 |
| 10' | 5304-0292 |

Herc-Alloy Sling Chains

Slings may be made up in any length, in any chain size, and with any combination of attachments. The styles shown are those most commonly used in the stone industry, but triple sling, quad sling, adjustable sling, basket and endless slings are available. Specification sheets are available. Slings are made to order at the factory. To make your own slings, or to connect attachments, use the Hammerlok coupling link. It is easy to insert and as dependable as the chain it couples.



2503-

Monument Straps



| Size | Item # |
|------|-----------|
| 12" | 5304-0481 |
| 18" | 5304-0478 |
| 28" | 5304-0479 |

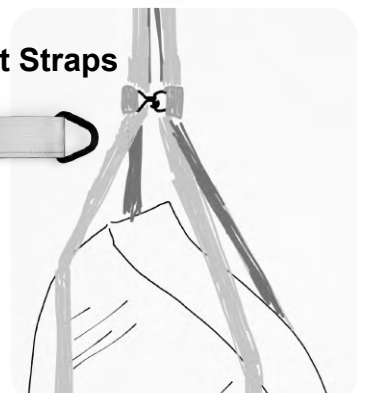

Display Strips



Developed for use between tablets and bases to help create a more uniform and attractive display. Use indoors or out, eliminates board stains. **Sold in 50 packs.**

| Size | Item # |
|-------------|-----------|
| 6"x1"x1/4" | 5108-0012 |
| 8"x1"x1/4" | 5108-0013 |
| 8"x1"x1/2" | 5108-0015 |
| 10"x1"x1/4" | 5108-0014 |

Other Thicknesses Available, Call For Listing

Setting Cushions



For cemetery setting, plastic cushions are corner set to maintain joint thickness of granite, marble and stone. Use between stone pieces when stacking for storage. Will not stain.

| Size | Bags: | Item # |
|-----------------|-------|-----------|
| 1" x 1" x 1/16" | 100 | 5108-0008 |
| 1" x 1" x 1/8" | 100 | 5108-0009 |
| 1" x 1" x 1/4" | 100 | 5108-0011 |
| 1" x 1" x 1/2" | 50 | 5108-0010 |

Green Sealer

Excellent adhesive properties allow this unique product to be used for a variety of setting applications. Ideal for securing bases or markers to precast foundation tops, setting tablets on bases and securing vases or other ornamentation.

Available in 1/4" x 1/2" x 21' rolls.



5105-0001

Silicone Caulking Sealant

This high performance architectural grade sealant forms a durable and flexible bond. Sealant adheres well to granite, marble, stone, concrete, steel, aluminum and many plastics. Temp. range is -60°F to +300°F. UV resistant and non staining.



| Color | Item# |
|----------|-----------|
| Aluminum | 5107-0002 |
| Black | 5107-0003 |
| Bronze | 5107-0004 |
| Clear | 5107-0005 |

Join-Tite Setting Compound

The most popular setting compound in the industry.



| Color | Gallon |
|------------|-----------|
| Light Grey | 5103-0003 |
| Dark Grey | 5103-0004 |
| Brown | 5103-0005 |

Aluminum, or Stainless Steel Dowels

Aluminum, or stainless steel dowels do not rust or deteriorate. Therefore, making permanent joints regardless of time or weather. Available in 3/8" to 1" diameters. Prices starting at 40¢ an Inch. Lengths from 2" to 36". Specify diameter, material needed, and length.



5102-0006 -- 5102-0013

Pine Shims

Shims come in cartons of 120 and are 8"

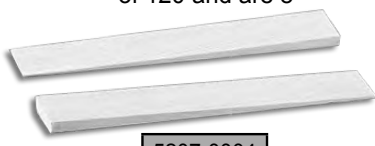

5207-0004

Composite Shims

- Pre-scored for easy snapping
- Greater load bearing than wood shims
- Use on all shimming applications
- Split resistant
- Waterproof



5207-0003

Taper Wedge Shim

U-shaped to fit around a 1/2" bolt



Thickness: 1/32" - 1/4"
Size: 1-1/2" x 3-3/8"



| 100pk | |
|-------|-----------|
| 1/4" | 5207-0014 |

Wobble Wedges



Wobble Wedges are used for leveling granite countertops. Ridged sides lock into place and prevent slipping.

| | |
|---------|-----------|
| BOX 75 | 5207-0002 |
| BOX 300 | 5207-0001 |

Wedge Lead



Most setters still use lead to avoid joint compression on setting compounds. Available in 25 lb. reels.

| Number | Size | Item # |
|--------|-------|-----------|
| #2 | 1/8" | 5108-0003 |
| #3 | 3/16" | 5108-0004 |
| #4 | 1/4" | 5108-0005 |



| Size | Item # |
|-------------------|-----------|
| Flat- 1"Wx1/4"T | 5108-0006 |
| Flat- 1/2"Wx1/8"T | 5108-0007 |



Paint Markers

Fine tips are the perfect markers used to draw lines on stone for sink cut-outs and radius templating. Holds up to water during the cut. Remove with steel wool. Quick drying, water resistant, smooth marking. Medium tips are for general stone identification marking. Made in the USA!

| | | | |
|-------------|-----------|------------|-----------|
| Fine White | 5209-0001 | Med. White | 5209-0003 |
| Fine Red | 5209-0002 | Med. Red | 5209-0004 |
| Fine Yellow | 5209-0059 | | |



Utility Knife

Comes with 3 blades.

0305-0036



Replacement Blades 100pk

0305-0045

Soapstone

Best quality. Suitable for temporary layout markings on granite, marble, and stone. Marks on any stone surface. 5" x 1/2" x 3/16".

2906-0004



Quantity Discounts

Holder 2906-0013

Wax Crayons

These non-staining waterproof crayons will mark on practically any surface, including glass. **Box of 12**

| Color | Item # |
|--------|-----------|
| Black | 2906-0005 |
| Red | 2906-0006 |
| Yellow | 2906-0007 |
| Blue | 2906-0019 |



Glaschrom Permanent Dry Marker Pencils

Quality. Not like a china marker, but like an actual pencil. Works better on wet stone. Needs to be cleaned up with razor blade or solvent.

| Color | Item # |
|--------|-----------|
| White | 2906-0023 |
| Yellow | 2906-0024 |
| Red | 2906-0025 |



Sold in boxes of 12.

Omnichrom Non-Permanent Dry Marker Pencils

Quality. Not like a china marker, but like an actual pencil. Will clean up with water. Doesn't work well on wet stone.

| Color | Item # |
|--------|-----------|
| White | 2906-0020 |
| Yellow | 2906-0021 |
| Red | 2906-0022 |



Sold in boxes of 12.

China Markers



Excellent for most surfaces. Pull string to sharpen. **Sold in boxes of 12.**

| Color | Item # |
|--------|-----------|
| Black | 2906-0009 |
| Red | 2906-0010 |
| Yellow | 2906-0011 |
| White | 2906-0012 |

Granite City Tool Stainless Steel Tape Measures



All components are made of stainless steel for improved rust resistance. They also have a new dual end hook for added versatility measuring.

| | |
|-------------------|-----------|
| 16' x 1" Standard | 5209-0022 |
| 25' x 1" Standard | 5209-0006 |

TRADES-MARKER® All Purpose Marker



Features a push-button advancing mechanism that allows the user to advance the stick as needed. Reduce tip breakage by easily retracting the marker back into the holder when not in use. Also, the durable plastic holder includes a convenient pocket-clip.

| Marker | Item # |
|-------------------|-----------|
| White Refill 6pc | 2906-0015 |
| Yellow Refill 6pc | 2906-0016 |
| Black Refill 6pc | 2906-0017 |
| Red Refill 6pc | 2906-0018 |

This is one form of low cost advertising that pays. Your firm name stands out on your choice of aluminum, stainless steel, or black aluminum. Standard length of plates is 3". Specify flat base or bent die plate type.

Name Plates

- Style 1: Black Letters
- Style 2: Black Letters and Line
- Style 3: Black Panel
- Style 4: Black Face Aluminum



| Type | Item # |
|---------------------------------|-----------|
| Flat Alum Etched | 1705-0006 |
| Bent Alum Etched | 1705-0013 |
| Flat Alum Litho | 1705-0007 |
| Bent Alum Litho | 1705-0008 |
| Flat S-Steel Etched | 1705-0009 |
| Bent S-Steel Etched | 1705-0010 |
| Bent S-Steel Litho | 1705-0011 |
| Flat Alum Etched w/ Adhesive | 1705-0002 |
| Flat S-Steel Etched w/ Adhesive | 1705-0004 |

**Single Sided
Razor Blades**



Made in U.S.A.

Box of 100

#9 0305-0011

Best Quality

**Deluxe Hand
Scraper**



For use with single edge razor blades.

0305-0049

Mini Scraper



0305-0091

Plastic Durable Hand Scraper
Easy to use snap & lock blade
Use with plastic or metal blades
Includes 1 plastic razor blade

The Shaveit



0305-0076

A 12 razor blade scraper with plastic handle.
Use caution

Squeegee



| | |
|-----------|-------------------------|
| 5209-0008 | H-14 Squeegee |
| 5209-0009 | Z-14 extra rubber blade |

The plated-steel frame provides ideal combination of strength and economy. The 2-ply soft-natural rubber blades yield performance superior to similar looking products. 14" wide.

White Rubber Mallet



2305-0081

- Will not mar tile or baseboard
- Rubber head securely mounted on wood handle

Granite City Scrub Brushes

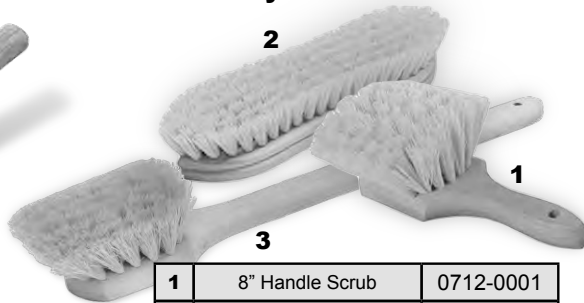

| | | |
|---|-----------------------|-----------|
| 1 | 8" Handle Scrub | 0712-0001 |
| 2 | 10.75" Pointed Hand | 0712-0002 |
| 3 | 20" Long Handle Scrub | 0712-0034 |

These inexpensive scrub brushes are a great favorite in the industry. Made with a substantial wooden block backing and long lasting fiber bristles designed to hold more cleaning solution than conventional brushes.

Pour Spouts



| | |
|--------|-----------|
| Quart | 0305-0003 |
| Gallon | 0305-0002 |

Glue Spreaders



Plastic 4" wide.
Sold in Boxes of 100

Box 100 0305-0017

Mixing Board



0305-0033

- Peel Away Non-Absorbing white sheets
- White Sheets allow for Accurate Color Mixing.
- Less Mess at Job Site and Shop.
- 100 Sheets per Board

RIVAL

Glue Stirring Sticks



One End Square

Box 500 0305-0083

**Measuring
Cups**



50 Pack 0305-0043

50ml Dual Gun



0305-0059

**Industrial Single
Caulking Gun**



0305-0029

**Heavy Duty
Caulking Gun**



Works great with 1:1 and 2:1 epoxy tubes.

0305-0030

**Heavy Duty Dual
Cartridge Gun**

1:1 cartridge gun can be converted to 2:1 with washer



| | |
|---------------------------|-----------|
| Dual Cartridge Gun, 300ml | 6001-0468 |
| 2:1 Conversion Washer | 0305-0044 |



Made in U.S.A.

Heavy Duty Yellow Rain Boots

| Size | Item # |
|------|-----------|
| 9 | 4501-0114 |
| 10 | 4501-0115 |
| 11 | 4501-0116 |
| 12 | 4501-0117 |
| 13 | 4501-0118 |
| 14 | 4501-0119 |
| 15 | 4501-0120 |

Built-up rubber construction, 100% waterproof while offering a comfortable fit. Non-absorbent polyester liner keep feet dry & warm.



Made in U.S.A.

#1 SELLER

Buffalo Steel Toe Boots

| Size | Item # |
|------|-----------|
| 8 | 4501-0065 |
| 9 | 4501-0066 |
| 10 | 4501-0067 |
| 11 | 4501-0068 |
| 12 | 4501-0069 |
| 13 | 4501-0070 |
| 14 | 4501-0071 |

Buffalo Steel Toe Boots are made of high molecular weight PVC for high abrasive wear. They are net lined for easy on and off, have V-bar molded shanks and safety toes that meet or exceed ANSI.



Rubber Application Gloves

These rubber application gloves offer great protection from abrasives and acids without hindering mobility. Long lasting and durable.

4703-0011



Great White Abrasion Resistant Gloves

Washable, resistant to chemicals, water and ultraviolet light. Seamless construction. Gray polyurethane coated grip for superior puncture and abrasion resistance.

| | |
|----|-----------|
| L | 4501-0136 |
| XL | 4501-0137 |



Hydra Spray 200

0704-0003

Model 200 Hydra Spray utilizes compressed air to increase normal in-line water pressure. This is a simple and economical tool to increase the effectiveness of your rinsing applications.



Knit Gloves with Latex Coating

4501-0094

Knit string gloves with full palm latex coating including the finger tips. Durable!



Disposable Nitrile Gloves

4 mil thick



IMPROVED

| | |
|----|-----------|
| M | 4501-0133 |
| L | 4501-0122 |
| XL | 4501-0063 |

100ea

- Economical puncture resistance
- Textured grip provides a good grip
- Contains no natural rubber latex proteins
- CFIA approved



Heavy-Duty Grouting Gloves

4501-0047

- Protects hands from the corrosive action of grout, chemicals and other harsh substances
- 100% heavy-duty latex is puncture and tear resistant



GCT Stone Sleeves

Fit snugly around wrist, and has adjustable strap.

4501-0127

STONE SLEEVE™ Fabricator Sleeves



4501-0076

The **STONE SLEEVE™** fabricator sleeves are the solution to wet polishing and working around natural stone with water fed tools. The wrist seal is soft, comfortable and absolutely water proof, guaranteed. The sleeve itself is a water proof poly coated Cordura.

**BULLET PROOF™
Fabricator Apron**



4501-0074

**DELUXE BULLET PROOF™
Fabricator Apron**



**Internal
Pocket**



Shoulder Strap



4501-0132

**Granite City Tool
Deluxe Heavy Duty Apron**

Made especially for stone fabricators. Two velcro strips are on the front to hold replacement pads. The apron also has 2 pockets in the front with dual closing design, which can hold cell phones and other valuables.



4501-0045

These aprons are light, durable and safe. With neoprene strapping and lightweight/ultra tough Cordura, you won't even know you have it on. It is extra long and wide to keep your legs dryer and it buckles behind you to keep you safe.



Stone Aprons

These new Granite City Tool aprons are durable and ready to take on your wettest projects. Coming in 2 styles Standard and Heavy Duty!

**No neck
strain ties!**



| | |
|------------------------------|-----------|
| Neoprene Lightweight 12.5oz. | 4501-0129 |
| Hycar Heavyweight 18oz. | 4501-0130 |

PVC Apron



Looking for a cheap waterproof apron?

We have now got a simple apron at the right price!

Get one today!

4501-0124

Fabricators Jacket



This jacket has it all: breathable waterproof construction, replaceable sleeves, oversized hood, and the "Bullet Proof" durability.

4501-0135



**Green Jacket
with
detachable
hood**

Constructed of heavy duty 0.40mm high density PVC on polyester to provide high abrasion resistance.

| | |
|----|-----------|
| L | 4501-0125 |
| XL | 4501-0126 |



**Yellow
Rain Suit**

Three piece heavy duty rain suit with vented back, jacket, bib and hood.

| Size | Item # |
|------|-----------|
| L | 4501-0040 |
| XL | 4501-0039 |
| XXL | 4501-0072 |

Yellow Rain Coat



| Size | Item # |
|------|-----------|
| M | 4501-0101 |
| L | 4501-0087 |
| XL | 4501-0088 |
| XXL | 4501-0089 |

- High quality PVC on polyester
- Adjustable waist, ankle & cuff take-up snaps for the perfect fit
- Two front snap pockets on jacket
- Underarm vents to keep you cool



IMER
U.S.A., Inc.

Workman II 250-350-450 Towable MultiMixers

Towing Safety:

Full width fenders and torsion bar suspension provide a smooth cruise to and from the jobsite.

Power:

Direct drive gearbox to the drum, no more external drive gears! This drive system is whisper quiet and is sealed for life... no maintenance required!

Reliability:

The jig-welded box steel frame is very strong and rigid, and includes a built in work platform. Tilt the mixer back, drop the support legs, and you have a mini batch plant.



Economical Power:



Now available with Yanmar Diesel Power, run all day on 2 quarts of fuel!

Extra Value:



Every mixer from IMER USA comes with a commercial duty tow hitch, not some welded on cheapie.

| WORKMAN II | 250 | 350 |
|-------------------------|-----------------|-----------------|
| Drum capacity | 9 cu. ft. | 12 cu. ft. |
| Batch output | 6 cu. ft. | 9.5 cu. ft. |
| Electric motor rating | 1.5 HP 110/220V | 1.5 HP 110/220V |
| Gas engine | 5.5 HP Honda | 5.5 HP Honda |
| Diesel engine | N / A | 5 HP Yanmar |
| Drum diameter | 27.5" | 32.5" |
| Discharge outlet height | 27.5" | 26.5" |
| Pneumatic wheels | 20" | 20" |
| Weight | 525 lbs. | 650 lbs. |

| | | |
|----------|-----------|-----------|
| Gas | 1002-0003 | 1002-0048 |
| Electric | 1002-0018 | 1002-0060 |

Heavy Duty Steel Concrete Forms



Many Sizes Available,
Call For Listing

5101-

Save installation time by precasting your foundation tops with these heavy duty forms.

10 gauge hot rolled steel.
Tapered sides.
Any size available.
4" depth standard- other depths available.

118



IMER
U.S.A., Inc.

Mortarman 120 PLUS Portable Vertical Shaft Mixers

Specifications:

Drum capacity: 4.5 cu. ft.

Batch output: 3 cu. ft.

Motor rating: 2 HP 110V, 15Amp.

Paddle speed: 38 RPM

Drum diameter: 30"

Machine weight: 286 lbs.

The Mortarman 120 PLUS is perfect for the 2-3 person construction crew. Why go through all the hassles of towing a mixer to the job site, when the Mortarman 120 PLUS can make a wheelbarrow of mortar, stucco, grout or dry pack mortar every 3 minutes!

Electric 1002-0081



**WACKER
NEUSON**

BS50-2 Vibratory Rammer

The standard in the construction industry. These rammers are powered by the exclusive WM 80, the only 2-stroke engine specifically designed and built for vibratory rammers and meets EPA and European air emission standards. WACKER's rugged rammers are designed for maximum production, performance and durability.

1001-0044



**WACKER
NEUSON**

WP 1550A Vibratory Plate Compactor

The WP 1550A Compactor is used for the compaction of granular materials and mixed materials with some cohesive content, and hot or cold asphalt in confined areas such as parking lots, bridge construction, and next to structures, curbs, and abutments.

1001-0005



118

ICS/ 680GC Diamond Chainsaw

The **NEW** 680GC represents a giant leap ahead in concrete chain saw performance. 5 years in the making, this saw is destined to be ICS's flagship. Stronger and more reliable than any gas saw ICS has ever produced, it will soon be the tool of choice for contractors across the globe.

Specifications:

- **Torque:** 37.2 in-lbs.
- **Weight:** 21 lbs.
- **Bar Cutting Depths:** 12" & 14"
- **Speeds:** 11500 +/- 500 rpm, 2800-3200 rpm idle
- **Horsepower:** 5 HP @ 9,500 RPM
- **Noise Level:** 100dB at 3 ft (1m)

| | |
|-----|-----------|
| 12" | 4902-0030 |
| 14" | 4902-0031 |



90 Day Limited Warranty

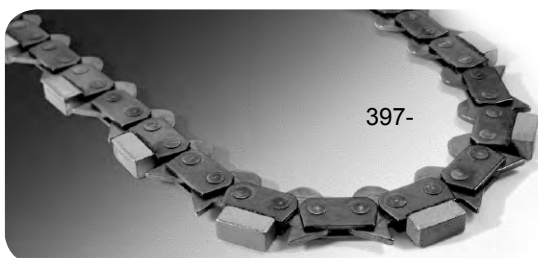

ICS/ Diamond Chains

- Chains Available:**
- SpeedMax™ Chain
 - Premium Chain
 - Abrasive Chain
 - TwinPro™ Chain
 - SpeedPro™ Chain
 - CornerPro™ Chain
 - Premium Plus Chain

Call for Pricing and Sizes

Frost Wedge



12" Under Collar

| Shank Size | Blade Size | Weight (lbs.) | Item# |
|---------------|------------|---------------|-----------|
| 7/8" x 3-1/4" | 1-7/8" | 6.2 | 3108-0004 |
| 1" x 4-1/4" | 1-7/8" | 6.4 | 3108-0001 |
| 1-1/8" x 6" | 2" | 10.5 | 3108-0003 |

Clay Spade for Breakers



| Shank Size | Blade Size | Weight (lbs.) | Item # |
|---------------|------------|---------------|-----------|
| 7/8" x 3-1/4" | 5-1/2" | 7.3 | 3106-0003 |
| 1" x 4-1/4" | 5-1/2" | 7.6 | 3106-0002 |
| 1-1/8" x 6" | 5-1/2" | 10.1 | 3106-0004 |
| | 8" | 13.6 | 3106-0006 |
| 1-1/4" x 6" | 4-1/2" | 10.3 | 3106-0007 |

3" Chisels



| Standard | | | |
|-------------|-------------|---------------|-----------|
| Shank Size | Length U.C. | Weight (lbs.) | Item# |
| 1" x 4-1/4" | 14" | 5.2 | 3105-0004 |
| 1-1/8" x 6" | 14" | 6.7 | 3105-0010 |
| | 18" | 7.9 | 3105-0036 |
| 1-1/4" x 6" | 18" | 9.5 | 3105-0039 |
| | 24" | 11.6 | 3105-0016 |
| Hi-Duty | | | |
| Shank Size | Length UC | Weight (lbs.) | Item# |
| 1-1/8" x 6" | 14" | 7.3 | 3105-0041 |

Moil Points and Narrow Chisels

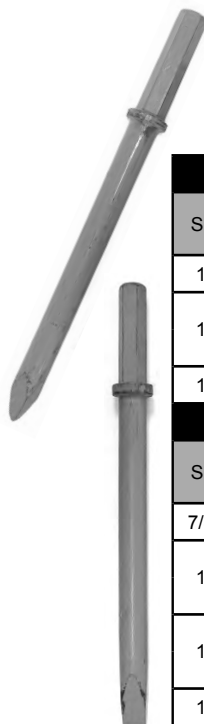

| Standard | | | | |
|---------------|-------------|---------------|------------|---------------|
| Shank Size | Length U.C. | Weight (lbs.) | Moil Point | Narrow Chisel |
| 1" x 4-1/4" | 14" | 4.5 | - | 3110-0040 |
| 1-1/8" x 6" | 14" | 5.9 | - | 3110-0043 |
| | 18" | 7.1 | - | 3110-0046 |
| 1-1/4" x 6" | 18" | 8.8 | - | 3110-0050 |
| Hi-Duty | | | | |
| Shank Size | Length U.C. | Weight (lbs.) | Moil Point | Narrow Chisel |
| 7/8" x 3-1/4" | 14" | 4.1 | 3110-0053 | - |
| 1" x 4-1/4" | 14" | 4.9 | - | 3105-0032 |
| | 18" | 6.1 | 3110-0054 | - |
| 1-1/8" x 6" | 14" | 6.6 | 3110-0052 | 3105-0035 |
| | 18" | 8 | 3110-0056 | 3105-0038 |
| 1-1/4" x 6" | 18" | 9.6 | 3110-0057 | 3105-0040 |

Ruemelin Sandblast, Curtain, and Filter Parts Available! Most From Stock!!

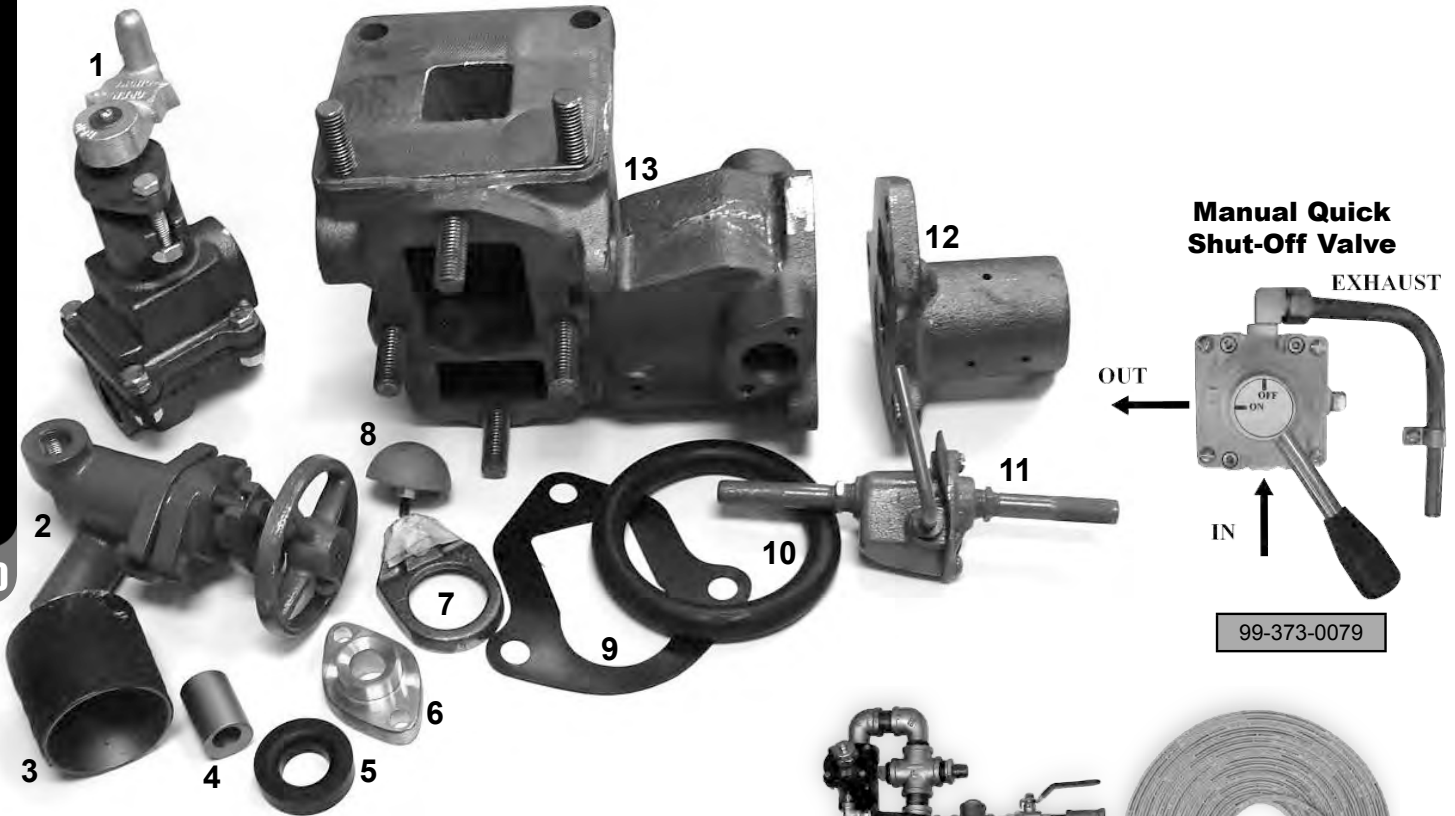

Manual Quick Shut-Off Valve

EXHAUST

OUT

IN

99-373-0079

Electric Quick Shut-Off Valve

- Electric shut off valve turns off abrasive with button and during power outage.

99-373-0098

This wall mounted push button Start/Stop switch is like the manual valve that will immediately stop releasing sand because residual pressure is dumped from the valve's exhaust port. This valve is also universal for any generator using air pressure to open and close the grit valve.



Ruemelin Style Conversion Kit

with urethane sleeve pneumatic 1-1/4 inch

99-290-0001

Replace your Ruemelin mixerbox with OSHA required "deadman".



CALL TODAY

RUEMELIN "Midget" Sandblast Generator

50 Pound Sand Capacity (1/2 cu. ft.)

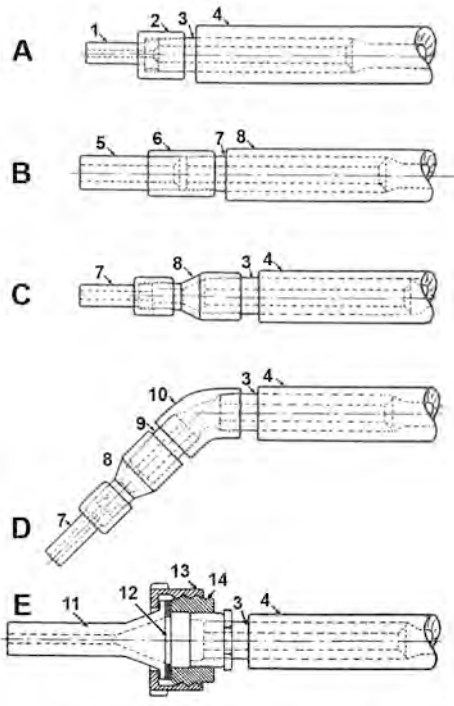
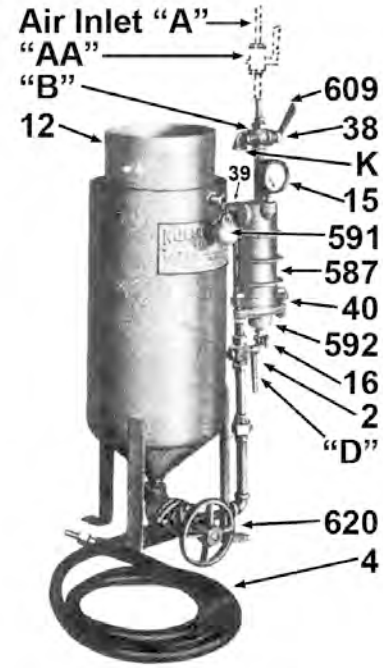
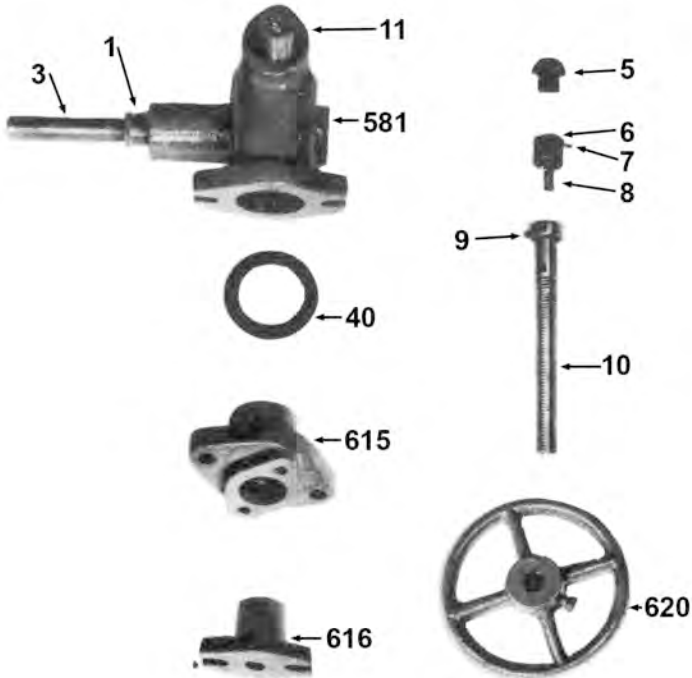

Nozzle Combinations

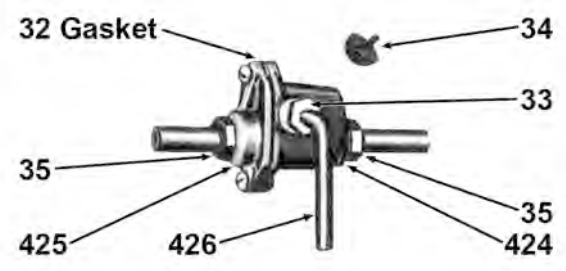

Blast Control Valve

RUEMELIN "Junior" Sandblast Generator

Sand Capacities 120 lbs., 200 lbs., 200 lbs., 300 lbs.

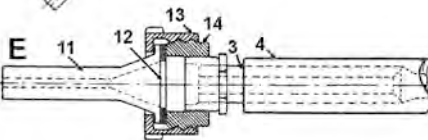
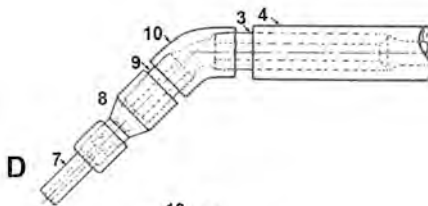
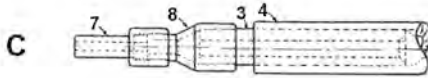
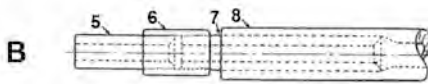
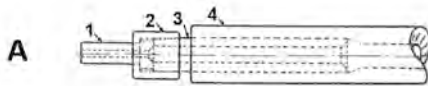
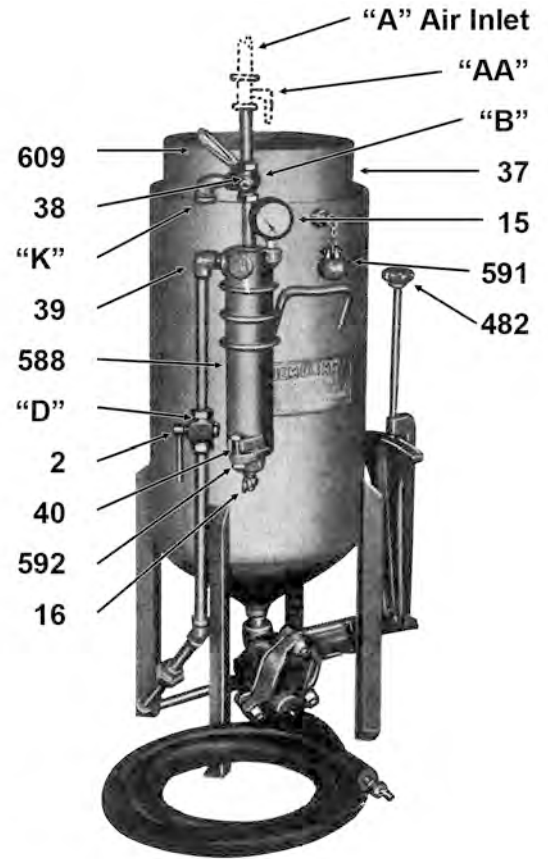
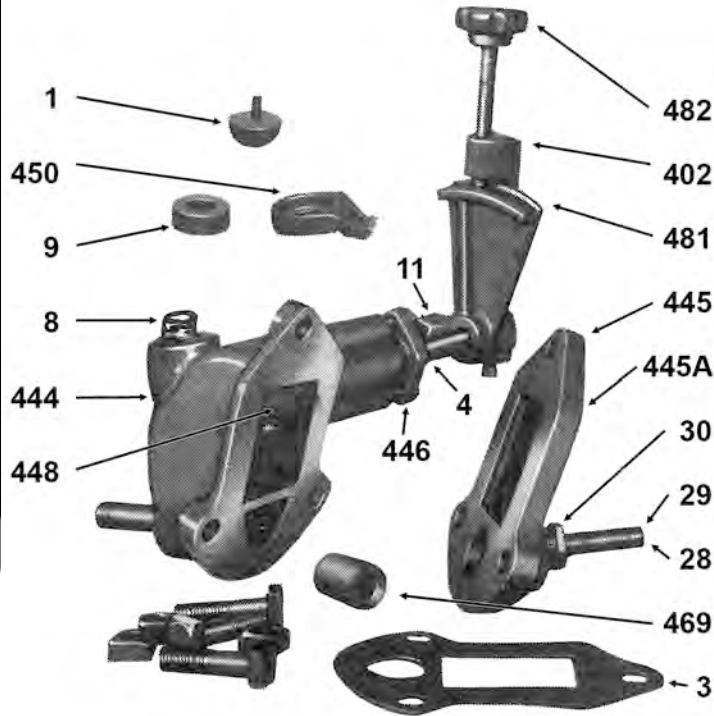

Nozzle Combinations



Blast Control Valve

RUEMELIN "MEDIUM" Sandblast Generator (4 to 6 cu. ft.)

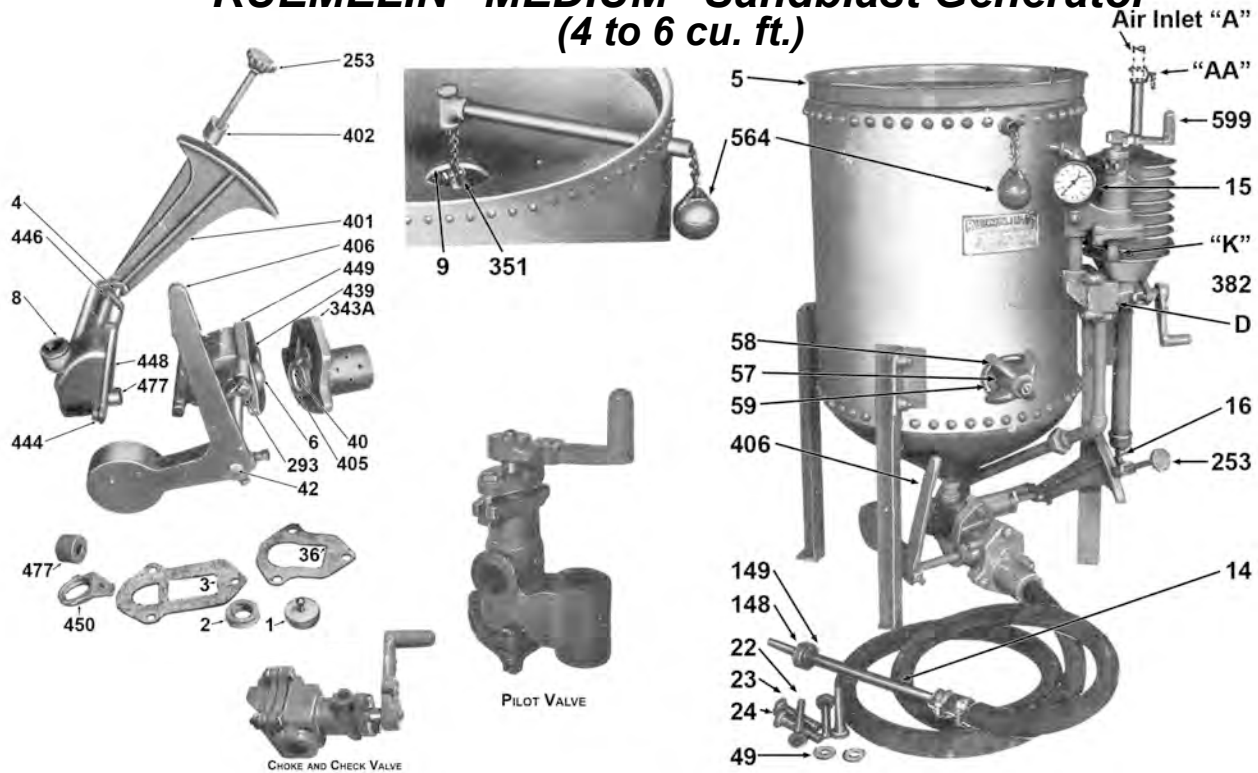

RUEMELIN "MASTER" Sandblast Generator (7 1/2 to 20 cu. ft.)

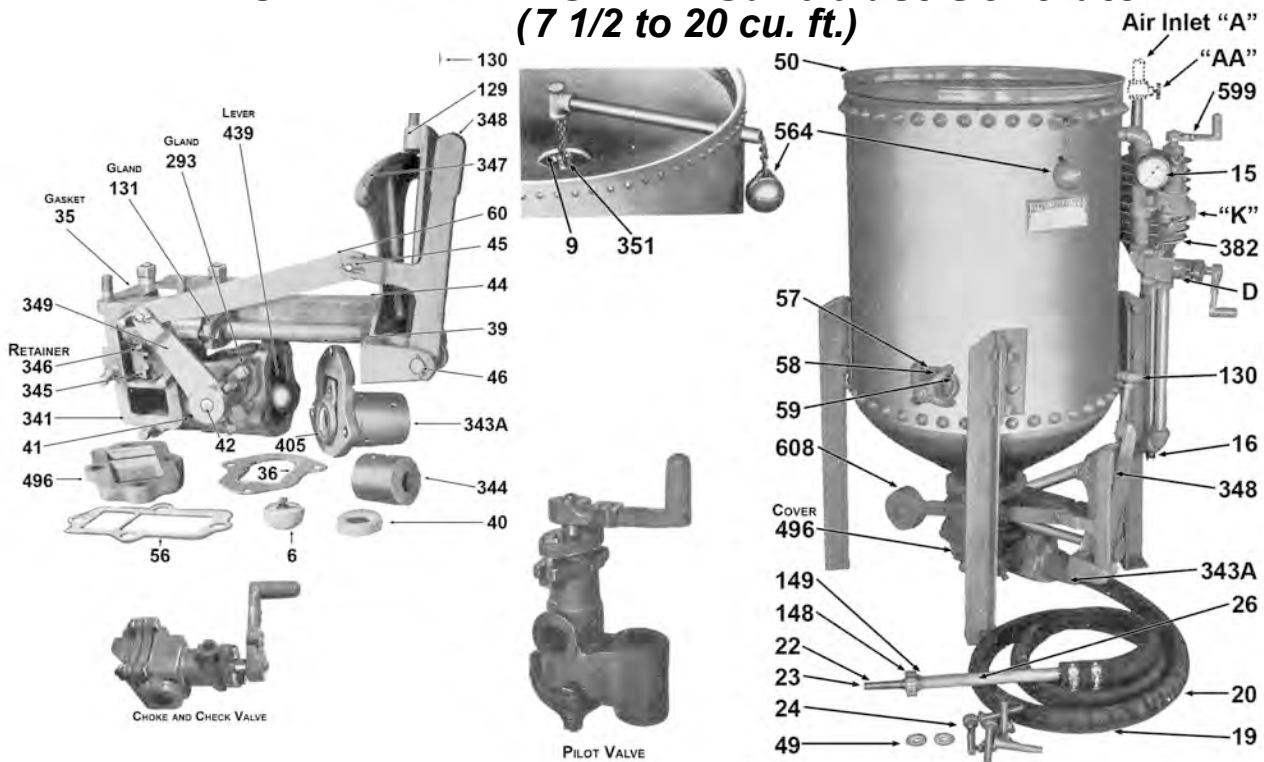

Common parts for "Midget" and "Master" Sandblast Generators



Lindsay Portable Abrasive Blasters

Models 15L, 25L, 35W, 100D

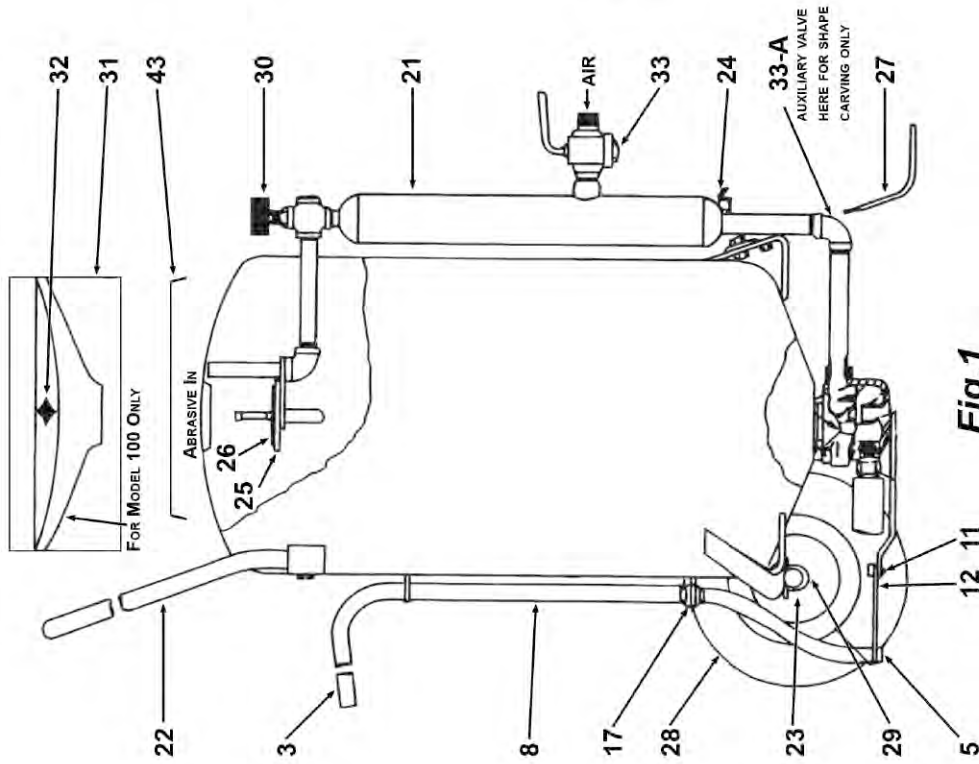

Fig. 1

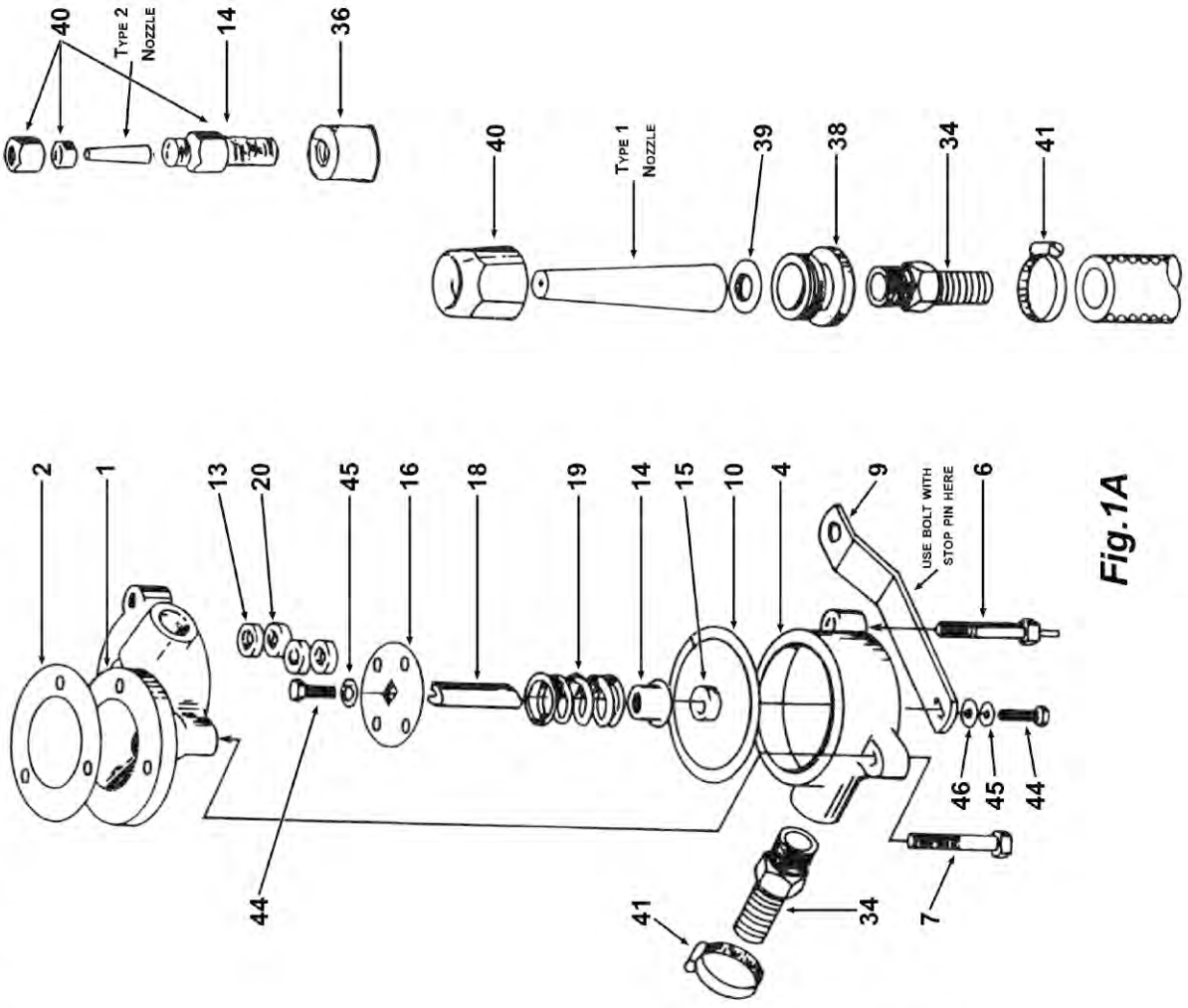

Fig. 1A

#5600 Pneumatic Abrasive Pickup

| Item No. | Description |
|----------|--------------------------------------|
| AP-1 | #700 STORAGE TANK BODY |
| AP-2 | #450 STORAGE TANK BODY |
| AP-3 | VENTURI HEAD (R-692) (10875) |
| AP-4 | AIR JET/AGC-187, AGC-218, OR AGC-250 |
| AP-5 | TEE 1 X 1 X 1 WITH PLUG & BUSHING |
| AP-6 | 1" X 4-1/2" LG. NIPPLE |
| AP-7 | 1" UNION |
| AP-8 | TEE 1 X 1 X 1/4 |
| AP-9 | PRESSURE GAUGE |
| AP-10 | 1/4" X 12" LONG NIPPLE |
| AP-11 | VACUUM GAUGE, 2-1/2" DIA. |
| AP-12 | ACCESS PLATE |
| AP-13 | ACCESS PLATE GASKET |
| AP-14 | 90° LONG TURN ELBOW |
| AP-15 | 2-1/2" NIPPLE (1539) |
| AP-16 | HOSE ADAPTER NIPPLE (1525) |
| AP-17 | 2" VACUUM HOSE, 15 FT. LONG |
| AP-18 | HOSE CLAMPS #40 |
| AP-19 | SUCTION PICK-UP TUBE |
| AP-20 | FLOW CONTROL COLLAR |
| AP-21 | SUCTION PICK-UP SHIELD |
| AP-22 | REMOVABLE SCREEN TRAY (4x4 MESH) |
| AP-23 | FLOOR HOPPER |
| AP-24 | 4" DIA. SOFT RUBBER RING |
| AP-25 | 4" CONE VALVE |
| AP-26 | CONE VALVE LEVER LESS WEIGHT |
| AP-27 | STORAGE TANK SCREEN (6X6 MESH) |
| AP-28 | CLEANING TOOL FOR VENTURI |
| AP-29 | RUBBER FLAP |
| AP-30 | VENTURI HEAD GASKET |
| AP-31 | CONE VALVE LEVER WEIGHT R-608 |
| AP-38 | "TEE-Y" PIPE FITTING |
| AP-17S | 2" VACUUM HOSE, 10 FT. LONG |

SCREEN ONLY - SPECIFY DIMENSION WHEN ORDERING **

4X4 MESH
6X6 MESH

** DIMENSIONS WILL BE ROUNDED OFF TO THE NEXT HIGHEST FOOT. CUSTOMER TO TRIM TO SUIT.

* ARE ALL ONE ASSEMBLY AND CANNOT BE PURCHASED SEPARATELY

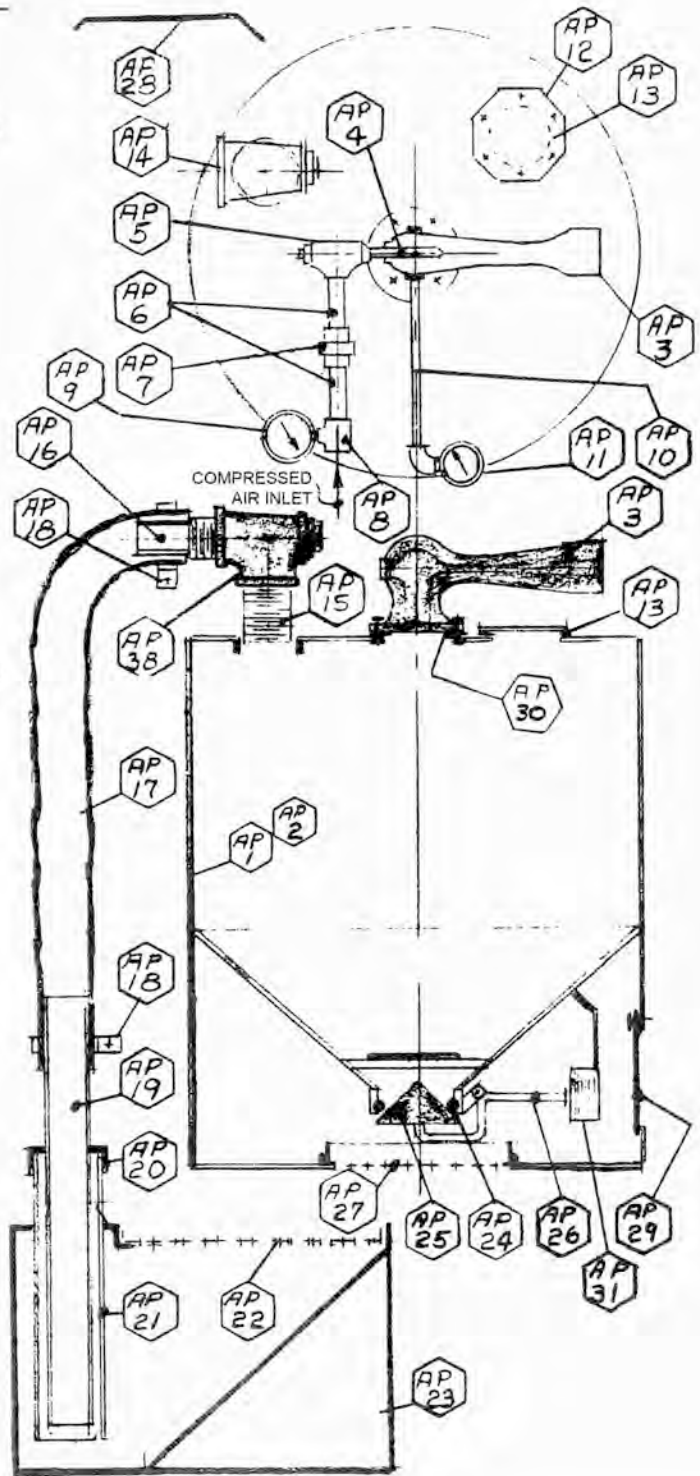

GENERAL INDEX

| | | | | | |
|---------------------------------------|----------|---------|---|----------|---------|
| 3M Stencil..... | # | 62 | Dallett Tools | D | 2 |
| | A | | Darkeners | | 88 |
| Abrasive Pickup..... | | 72 | Diamond Blades | | 42-46 |
| Abrasive Pickup Parts Lists | | 127 | Diamond Drum Wheels | | 34-36 |
| Abrasives | | 76 | Diamond Grinding & Shaping Wheels..... | | 28 |
| Adapter, Hose Fittings, GFCI..... | | 56 | Diamond Grinding Wheels & Silicon Carbide.... | | 26 |
| Adapter, Quad Drive | | 56 | Diamond Polishing Discs | | 29 |
| Adhesives..... | | 91 | Diamond Polishing Wheels & Buffing | | 22, 24 |
| Air Compressors & Accessories..... | | 97-103 | Diamond Routers & Profile Bits | | 37 |
| Air Filtration System | | 72 | Diamond Wire | | 51 |
| Air Hose..... | | 101 | Die Grinders | | 13 |
| Air Polishers | | 54 | Drill Bits..... | | 18-19 |
| Aluminum Oxide Grinding Wheels | | 10 | Dust Collectors | | 72 |
| Anchor Stencil | | 64 | | E | |
| Antiquing Brushes | | 22-23 | Ear Plugs | | 84 |
| Aprons | | 117 | Edge Shaping Machines | | 35 |
| Automatic Sandblast Rooms..... | | 72 | Enhancers & Darkeners | | 88 |
| | B | | Etching Tools & Machines | | 15-16 |
| Backer Heads..... | | 33 | | F | |
| Bars, Setting | | 110 | Filler, Sandblast..... | | 61 |
| Blades..... | | 42-46 | Filler Remover..... | | 61 |
| Booms, Forklift | | 110 | Forklift Boom | | 110 |
| Boots | | 116 | Frankfurt Bricks & Brushes..... | | 26 |
| Buffing Supplies | | 24-25 | | G | |
| | C | | Garnet Sand | | 76 |
| Carbide Nozzles | | 73 | Gloves..... | | 116 |
| Carbide Tipped Chisels..... | | 3-7 | Grinders..... | | 52-55 |
| Carving Tools | | 2 | Grinding Wheels | | 26 |
| Caulking, Silicone..... | | 113 | | H | |
| Ceramic Nozzles | | 73 | Hammer Drills | | 17 |
| Chainsaw..... | | 119 | Hammers | | 8-11 |
| Chisels & Hammers..... | | 2-12 | Hand Pads | | 32 |
| Chisels Carbide Tipped..... | | 3-7 | Hoods & Safety Equipment | | 80-81 |
| Chisels Steel Tipped | | 7 | Hose (Air, Exhaust, Sandblast) | | 101 |
| Clamps, Hand..... | | 104 | Hose Reel | | 102 |
| Clamps, Lifting..... | | 109 | | I | |
| Cleaners | | 85 | Impact Etching Machines | | 16 |
| Color Paste..... | | 93 | | K | |
| Concrete Forms | | 118 | Knife..... | | 68 |
| Concrete Mixers..... | | 118 | | L | |
| Construction | | 118 | Lead, Wedge | | 113 |
| Core Bits..... | | 40-41 | Lettering, SKS..... | | 66 |
| Core Drill Machines & Core Bits | | 39 | Lettering, Spacerite | | 65 |
| Couplings | | 103 | Lifting Clamps | | 109 |
| Cranes | | 105-107 | Lifting Beam..... | | 111 |
| Crayons | | 114 | Lindsay Parts | | 125-126 |
| Cup Wheels | | 28 | Lithichrome | | 77-78 |
| Cups, Hand..... | | 104 | | | |

M

Marble Blades45
 Markers, Pencils 114
 Masks, Filter80
 Mixers 118

N

Name Plates 114
 Nozzles73, 74

O

Oil..... 101

P

Paint, Stone..... 77-78
 Paper (Tracing, Rubbing Carbon)67
 Pencils, Markers 114
 Plates, Name 114
 Plotters, Stencil 57-59
 Plotter Software57
 Polish.....86, 89
 Polishers54
 Polishers & Grinders..... 52, 54-55
 Polishers, Air54
 Polishers, Planetary55
 Polishing Wheels.....21
 Polyester Resin..... 91-93
 Portable Air Compressors 97-99
 Pour Spouts 115
 Profiler Bits35

R

Radial Arm Wheels21
 Repair 86, 89-90, 92
 Respirators.....80
 Rock Drill.....17
 Rollers & Shackles 111
 Router Bits37, 38
 Ruemelin Parts 120-124
 Ruler67

S

Safety Glasses84
 Sandblast & Abrasives.....69, 72
 Sandblast Filler.....61
 Sandblast Hoods80, 81
 Sandblast Rooms - Automatic 71
 Sandblast Tanks69
 Sanding Belts.....26
 Sanding Discs.....27
 Saws 47-51
 Saws, Wire..... 50-51
 Sculptor Tools..... 13-14, 82-83

Sealers.....85
 Setting & Handling104-112
 Setting (Sealer, Strips, Caulk) 113
 Setting Bars 110
 Setting Compound113
 Setting System.....109
 Setting Trucks.....108
 Shackles & Rollers 111
 Shaping Wheels.....28
 Shims & Wedges 113
 Sight Screen.....68
 Silicon Carbide Discs.....26
 Silicon Carbide Grinding Wheels..... 10, 26
 SKS Lettering.....66
 Slings..... 112
 Software, Stencil.....57
 Spacerite Lettering65
 Spot Removers 85-86
 Steel Tipped Chisels7
 Stencil Tools & Stencil57, 64
 Stencil, 3M.....62
 Stencil, Anchor64
 Stencil, U-Blast63
 Stain & Rust Remover.....87
 Stone Care & Repair..... 86, 89-90, 92
 Stone Drills & Bits 17-19
 Stone Essentials Sealers.....86, 88
 Stone Etching Tools 15
 Stone Paint..... 77-78
 Stone Saws 47-51
 Stone Splitting Shims & Wedges20

T

Tape60
 Tripods.....107
 Trucks 108
 Tuck Point Rodding Blades46
 Turbo Blades..... 43-45

U

U-Blast Stencil63

V

Valves 102-103
 Vibratory Rammer & Compactor 118

W

Wedge Lead 113
 Wedges & Shims20
 Wire Saws..... 50-51
 Wire, Diamond51

Liability: The following statement is made in lieu of all warranties, expressed or implied. Granite City Tool and/or manufacturer's only obligation shall be to replace such quantity of product proven to be defective provided that such guarantees or replacement are a stated policy of the manufacturer. Granite City Tool and/or manufacturer shall not be liable for any injury, loss or damage, direct, incidental or consequential, arising out of the use or the inability to use the product. Before using, user shall determine the suitability of the product for its intended use, and user assumes all risk and liability whatsoever in connection herewith. The foregoing may not be altered except by officers of Granite City Tool.

COLORS FOR EVERY APPLICATION.

Tough • Durable • Non-Fading

Lithichrome

Lithco colors are the result of many years experience in keeping abreast of the progress made in the field of surface coating in recent years. From every weathering angle Lithco colors are proven to be as durable as any color materials. Ultra-violet light in sunlight is the chief source of pigment and binder deterioration and Lithco Colors are compounded from the most sunlight-resistant pigments and resins available. To provide the highest level of performance a coating must have good adhesion to the surface, which is entirely dependent upon correct initial application by the stone working professional. The best procedure for bonding Lithco Colors to stone surfaces is to first apply a thinned (reduced by about half with Lithco Solvent) color followed by a regular coat.



Black, White, & Clear Also Available

Call Today 1-800-328-7094



PG. 78

Excellent Weather/UV Resistance • Quick Drying • Long Lasting

Granite City Tool

820 Sundial Drive
Waite Park, MN 56387



800-328-7094 Toll Free
320-251-1381 Toll Free Fax

granitecitytool.com

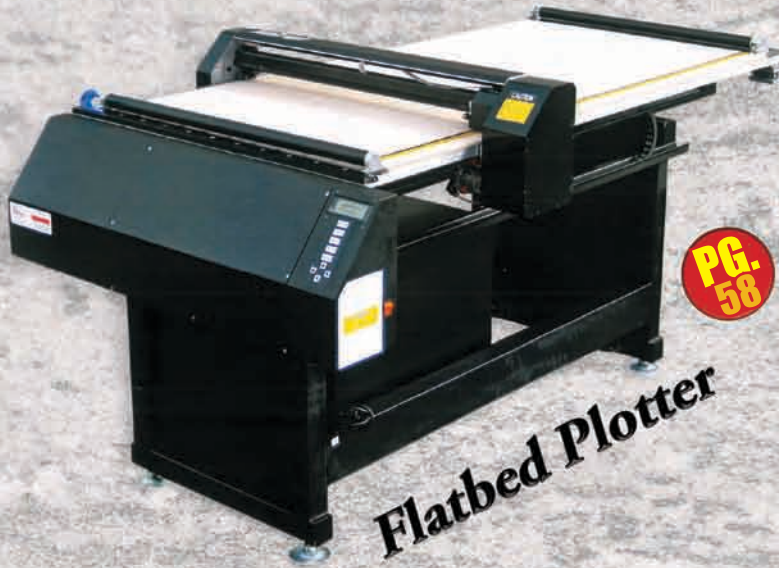

PG. 58

Flatbed Plotter



PG. 108

Monument Lifter



PG. 71

ABC Automatic Sandblast Room



PG. 71

Turbo Blaster